



OPERATORS & SAFETY SERVICE & MAINTENANCE ILLUSTRATED PARTS

Models

CM2033

CM2046

CM2546

CM2558

3120573

October 01, 1995

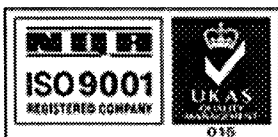

AUSTRALIAN OFFICE

JLG INDUSTRIES, INC.
P.O. Box 5119
11 Bolwarra Road
Port Macquarie, Australia
Telephone: 065 811111
Fax: 065 810122

EUROPEAN OFFICE

JLG INDUSTRIES (EUROPE)
Kilmartin Place,
Tannochside Park
Uddingston, Scotland, G71 5PH
Telephone: 01698 811005
Main Fax: 01698 811055
Parts Fax: 01698 811455

CORPORATE OFFICE

JLG INDUSTRIES, INC.
1 JLG Drive
McConnellsburg, PA.
17233-9533
USA
Telephone: (717) 485-5161
Fax: (717) 485-6417

FOREWORD

The purpose of this manual is to provide the customer with the operating procedures essential for the promotion of proper machine operation for its intended purpose. It is important to over-stress proper usage. All information in this manual should be READ and UNDERSTOOD before any attempt is made to operate the machine. YOUR OPERATING MANUAL IS YOUR MOST IMPORTANT TOOL - Keep it with the machine.

SINCE THE MANUFACTURER HAS NO DIRECT CONTROL OVER MACHINE APPLICATION AND OPERATION, CONFORMANCE WITH GOOD SAFETY PRACTICE IN THIS AREA IS THE RESPONSIBILITY OF THE USER AND HIS OPERATING PERSONNEL.

ALL PROCEDURES HEREIN ARE BASED ON THE USE OF THE MACHINE UNDER PROPER OPERATING CONDITIONS, WITH NO DEVIATIONS FROM THE ORIGINAL DESIGN. ALTERATION AND/OR MODIFICATION OF THE MACHINE IS STRICTLY FORBIDDEN WITHOUT WRITTEN APPROVAL FROM JLG INDUSTRIES, INC.

A MOST IMPORTANT FACT TO REMEMBER IS THAT ANY EQUIPMENT IS ONLY AS SAFE AS THOSE WHO OPERATE IT.

DANGER, WARNING, CAUTION, IMPORTANT, INSTRUCTIONS AND NOTE DEFINITIONS

Since safety of personnel and proper use of the machine are of primary concern, DANGER, WARNING, CAUTION, IMPORTANT, INSTRUCTIONS and NOTES are inserted throughout this manual to emphasize these areas. They are defined as follows:

DANGER

IF NOT CORRECTLY FOLLOWED THERE IS A HIGH PROBABILITY OF SERIOUS INJURY OR DEATH TO PERSONNEL.

WARNING or CAUTION

IF NOT CORRECTLY FOLLOWED THERE IS SOME POSSIBILITY OF SERIOUS INJURY OR DEATH TO PERSONNEL.



THE "SAFETY ALERT SYMBOL" IS USED TO CALL ATTENTION TO POTENTIAL HAZARDS WHICH MAY LEAD TO DEATH OR SERIOUS INJURY IF IGNORED.

IMPORTANT OR INSTRUCTIONS

DENOTES PROCEDURES ESSENTIAL TO SAFE OPERATION AND PREVENTION OF DAMAGE TO OR DESTRUCTION OF MACHINE.

Note

Provides information of special interest to illustrate the text.

All procedures herein are based on the use of the machine under proper operating conditions, with no deviations from original design intent ... as per OSHA regulations.

READ & HEED!

The ownership, use, service, and/or maintenance of this machine is subject to various federal, state and local laws and regulations. It is the responsibility of the owner/user to be knowledgeable of these laws and regulations and to comply with them. The most prevalent regulations of this type are the Federal OSHA Safety Regulations*. Listed below, in abbreviated form are some of the requirements of Federal OSHA regulations in effect as of the date of publication of this handbook.

The listing of these requirements shall not relieve the owner/user of the responsibility and obligation to determine all applicable laws and regulations and their exact wording and requirements, and to comply with the requirements. Nor shall the listing of these requirements constitute an assumption of responsibility of liability on the part of JLG Industries, Inc.

1. Only trained and authorized operators shall be permitted to operate the aerial lift.
2. A malfunctioning lift shall be shut down until repaired.
3. The controls shall be plainly marked as to their function.
4. The controls shall be tested each day prior to use to determine that they are in safe operating condition.
5. When applicable to local regulations or job site/employer safety rules, all personnel in the platform shall wear an approved safety belt with the lanyard attached to the platform attachment point.

6. Load limits specified by the manufacturer shall not be exceeded.
7. Instruction and warning placards must be legible.
8. Aerial lifts may be "field modified" for uses other than those intended by the manufacturer only if certified in writing by the manufacturer or an equivalent entity, such as a nationally recognized testing lab, to be in conformity to applicable OSHA safety regulations and to be at least as safe as it was prior to modification.
9. Aerial lifts shall not be used near electric power lines unless the lines have been deenergized or adequate clearance is maintained (see OSHA 20 CFR 1910.67 and 1926.400).
10. Employees using aerial lifts shall be instructed how to recognize and avoid unsafe conditions and hazards.
11. Ground controls shall not be operated unless permission has been obtained from personnel in the platform, except in case of an emergency.
12. Regular inspection of the job site and aerial lift shall be performed by competent persons.
13. Personnel shall always stand on the floor of the platform, not on boxes, planks, railing or other devices for a work position.

*Applicable Federal OSHA regulations, as of the date of publication of this manual include, but are not limited to, 29 CFR 1910.67, 29 CFR 1926.20, 29 CFR 1926.21, 29 CFR 1926.28, 29 CFR 1926.400 and 29 CFR 1926.556. Consult the current regulations for the exact wording and full text of the requirements and contact the closest Federal OSHA office for specific interpretations.

A. GENERAL.

1. This section contains the general safety precautions which must be observed during maintenance of the aerial platform. It is of utmost importance that maintenance personnel pay strict attention to these warnings and precautions to avoid possible injury to themselves or others or damage to the equipment. A maintenance program must be established by a qualified person and must be followed to ensure that the machine is safe to operate.

WARNING

MODIFICATION OF THE MACHINE WITHOUT CERTIFICATION BY A RESPONSIBLE AUTHORITY THAT THE MACHINE IS AT LEAST AS SAFE AS ORIGINALLY MANUFACTURED IS A SAFETY VIOLATION.

2. The specific precautions to be observed during machine maintenance are inserted at the appropriate point in the manual. These precautions are, for the most part, those that apply when servicing hydraulic and larger machine component parts.
3. Your safety, and that of others, is the first consideration when engaging in the maintenance of equipment. Always be conscious of weight.

Never attempt to move heavy parts without the aid of a mechanical device. Do not allow heavy objects to rest in an unstable position. When raising a portion of the equipment, ensure that adequate support is provided.

WARNING

SINCE THE MACHINE MANUFACTURER HAS NO DIRECT CONTROL OVER THE FIELD INSPECTION AND MAINTENANCE, SAFETY IN THIS AREA IS THE RESPONSIBILITY OF THE OWNER/OPERATOR.

B. HYDRAULIC SYSTEM SAFETY.

1. It should be particularly noted that the machines hydraulic systems operate at extremely high and potentially dangerous pressures. Every effort should be made to relieve any system pressure prior to disconnecting or removing any portion of the system.

2. Relieve system pressure by cycling the applicable control several times with the engine stopped and ignition on, to direct any line pressure back into the return line to the reservoir. Pressure feed lines to system components can then be disconnected with minimal fluid loss.

C. MAINTENANCE.**WARNING**

FAILURE TO COMPLY WITH SAFETY PRECAUTIONS LISTED IN THIS SECTION MAY RESULT IN MACHINE DAMAGE, PERSONNEL INJURY OR DEATH AND IS A SAFETY VIOLATION.

REMOVE ALL RINGS, WATCHES, AND JEWELRY WHEN PERFORMING ANY MAINTENANCE.

DO NOT WEAR LONG HAIR UNRESTRAINED, OR LOOSE FITTING CLOTHING AND NECKTIES WHICH ARE APT TO BECOME CAUGHT ON OR ENTANGLED IN EQUIPMENT.

OBSERVE AND OBEY ALL WARNINGS AND CAUTIONS ON MACHINE AND IN SERVICE MANUAL.

KEEP OIL, GREASE, WATER, ETC. WIPED FROM STANDING SURFACES AND HAND HOLDS.

NEVER WORK UNDER AN ELEVATED PLATFORM UNTIL SAFETY PROPS HAVE BEEN ENGAGED OR PLATFORM HAS BEEN SAFELY RESTRAINED FROM ANY MOVEMENT BY BLOCKING OR OVERHEAD SLING.

BEFORE MAKING ADJUSTMENTS, LUBRICATING OR PERFORMING ANY OTHER MAINTENANCE, SHUT OFF ALL POWER CONTROLS.

BATTERY SHOULD ALWAYS BE DISCONNECTED DURING REPLACEMENT OF ELECTRICAL COMPONENTS.

KEEP ALL SUPPORT EQUIPMENT AND ATTACHMENTS STOWED IN THEIR PROPER PLACE.

USE ONLY APPROVED, NONFLAMMABLE CLEANING SOLVENTS.

CM2033-2558
3120573 PARTS MANUAL
REVISION LOG

June 1991 - Original Issue

November 1992 - Revised

March 1993 - Revised

June 1994 - Revised

January 1995 - Change 1

Pages Affected:

Cover

Revision Log - Page c/d Blank

Table of Contents - Page iii and Page iv

Section 11 - Table of Contents - Page 11-0-1

Section 11-1 - Pages 11-1-5 to 11-1-7 and 11-1-17 to 11-1-19

Section 11-2 - Pages 11-2-4, 11-2-13, 11-2-17, 11-2-22, 11-2-26, 11-2-27 and 11-2-32

Section 11-3 - Pages 11-3-3 and 11-3-3B

Section 11-4 - Pages 11-4-1, 11-4-6, 11-4-7, 11-4-13, 11-4-15, 11-4-16, 11-4-17, 11-4-17A,
11-4-17B, 11-4-17C, 11-4-17D, 11-4-18, 11-4-19, 11-4-19A, 11-4-19B, 11-4-25
11-4-26 and 11-4-27

Section 11-6 - Pages 11-6-1, 11-6-7 and 11-6-8

Section 11-7 - Pages 11-7-1, 11-7-4, 11-7-13 to 11-7-16

Section 11-9 - Pages 11-9-1 and 11-9-2

June 1995 - Change 2

Pages Affected:

Cover

Foreword - Page a

Revision Log - Page c/d Blank

Section 1 - Page 1-3

Section 4 - Pages 4-1 and 4-4

Section 5 - Page 5-1

Section 7 - Pages 7-1, 7-2, 7-4 and 7-5

Section 8 - Pages 8-3 and 8-4

October 1995 - Change 3

Pages Affected:

Cover

Revision Log - Page c/d Blank

Section 2 - Page 2-3

Section 11 - Table of Contents - Page 11-0-2

Section 11-1 - Pages 11-1-3 to 11-1-7, 11-1-11, 11-1-15 and 11-1-18

Section 11-2 - Pages 11-2-4 to 11-2-6, 11-2-9 to 11-2-11, 11-2-15, 11-2-19, 11-2-27, 11-2-29
and 11-2-30

Section 11-3 - Pages 11-3-3 to 11-3-3B, 11-3-5 and 11-3-6

Section 11-4 - Pages 11-4-5 to 11-4-7, 11-4-13, 11-4-15, 11-4-16, 11-4-17 to 11-4-17B, 11-4-18,
11-4-19 to 11-4-19B and 11-4-25 to 11-4-27

Section 11-5 - Pages 11-5-7 and 11-5-13

Section 11-6 - Pages 11-6-5 and 11-6-8

Section 11-7 - Pages 11-7-2 to 11-7-13

Section 11-8 - Pages 11-8-1 to 11-8-8

TABLE OF CONTENTS

SUBJECT - SECTION, PARAGRAPH	PAGE NO.
INTRODUCTION - OPERATION SAFETY PRECAUTIONS	a
INTRODUCTION - MAINTENANCE SAFETY PRECAUTIONS	b
TABLE OF CONTENTS	i
LIST OF ILLUSTRATIONS	iii
LIST OF TABLES	iv
 SECTION 1 — SAFETY PRECAUTIONS	
1-1. General	1-1
1-2. Driving/Towing/Carrying	1-1
1-3. Electrocution Hazard	1-2
1-4. Pre-Operational	1-3
1-5. Driving	1-4
1-6. Operation	1-5
1-7. Towing and Hauling	1-9
1-8. Maintenance	1-10
 SECTION 2 — PREPARATION AND INSPECTION	
2-1. General	2-1
2-2. Preparation For Use	2-1
2-3. Delivery and Periodic Inspection	2-1
2-4. Daily Walk-Around Inspection	2-2
2-5. Daily Functional Check	2-2
2-6. Torque Requirements	2-3
2-7. Battery Charging	2-3
 SECTION 3 — USER RESPONSIBILITIES AND MACHINE CONTROL	
3-1. General	3-1
3-2. Personnel Training	3-1
3-3. Operating Characteristics and Limitations	3-1
3-4. Controls and Indicators	3-2
 SECTION 4 — MACHINE OPERATION	
4-1. Description	4-1
4-2. General	4-1
4-3. Motor Operation	4-1
4-4. Raising and Lowering (Lifting)	4-2
4-5. Platform Extension (If Equipped)	4-2
4-6. Steering	4-2
4-7. Traveling (Driving)	4-3
4-8. Parking and Stowing	4-4
4-9. Platform Loading	4-4
4-10. Safety Prop	4-4
4-11. Tie Down and Lifting	4-4
4-12. Towing	4-4
 SECTION 5 — OPTIONAL EQUIPMENT	
5-1. PQ Controller	5-1
5-2. Horn	5-1
5-3. Travel Alarm	5-1
5-4. Motion Alarm	5-1
5-5. Descent Alarm	5-1
5-6. Tilt Alarm	5-1

TABLE OF CONTENTS

SUBJECT-SECTION, PARAGRAPH	PAGE NO.
SECTION 5 — OPTIONAL EQUIPMENT (cont.)	
5-7. 110 Volt Generator	5-1
5-8. 110 Volt Receptacle	5-1
5-9. Platform Work Lights	5-1
5-10. Foam Filled Tires (CM2046 and CM2558 Only)	5-1
5-11. Non-Marking Tires	5-1
5-12. Rotating Beacon	5-1
5-13. High Output Batteries (CM2046, CM2546 and CM2558 Only)	5-1
5-14. Battery Condition Indicator	5-1
5-15. Fold-Down Hand Rails	5-1
5-16. Control Box Cover (Standard Controls Only)	5-1
5-17. Lifting Lugs	5-1
5-18. Powered Deck Extension	5-1
SECTION 6 — EMERGENCY PROCEDURES	
6-1. General	6-1
6-2. Emergency Towing Procedures	6-1
6-3. Emergency Controls and Their Locations	6-1
6-4. Emergency Operation	6-1
6-5. Incident Notifications	6-2
SECTION 7 — SPECIFICATIONS	
7-1. Capacities	7-1
7-2. Component Data	7-1
7-3. Performance Data	7-1
7-4. Torque Requirements	7-2
7-5. Lubrication	7-2
7-6. Cylinder Specifications	7-2
7-7. Pressure Settings	7-5
7-8. Serial Number Locations	7-5
7-9. Limit Switches	7-5
7-10. Major Component Weights	7-5
7-11. Critical Stability Weights	7-5
SECTION 8 — PROCEDURES	
8-1. General	8-1
8-2. Servicing and Maintenance Guidelines	8-1
8-3. Lubrication Information	8-2
8-4. Cylinders - Theory of Operation	8-3
8-5. Valves - Theory of Operation	8-3
8-6. Component Functional Description	8-4
8-7. Wear Pads	8-4
8-8. Cylinder Checking Procedures	8-5
8-9. Cylinder Removal and Installation	8-5
8-10. Cylinder Repair (Except Brake Cylinder)	8-6
8-11. Brake Cylinder Repair	8-9
8-12. Tilt Alarm Switch (If Equipped)	8-11
8-13. Limit Switch Adjustment	8-12
8-14. Pressure Setting Procedures	8-12
8-15. Preventive Maintenance and Inspection Schedule	8-16
SECTION 9 — TROUBLESHOOTING	
9-1. General	9-1
9-2. Troubleshooting Information	9-1
9-3. Hydraulic Circuit Checks	9-1

TABLE OF CONTENTS

SUBJECT-SECTION, PARAGRAPH PAGE NO.

SECTION 10 — RECOMMENDED SPARE PARTS LIST

Recommended Spare Parts List	10-1
------------------------------------	------

SECTION 11 — ILLUSTRATED PARTS LIST

Table of Contents	11-0-1
11-7-1 Electrical Diagrams and Components Chart	11-7-2

LIST OF ILLUSTRATIONS

FIGURE NO.	TITLE	PAGE NO.
2-1	Daily Walk-Around Inspection	2-4
3-1	Ground Control Station - CM2033/CM2046/CM2546/CM2558	3-4
3-2	Platform Control Station w/o PQ Controller - CM2033/CM2046/CM2546/CM2558 (Machines Built Before August 1992)	3-5
3-3	Platform Control Station w/PQ Controller - CM2033/CM2046/CM2546/CM2558 (Machines Built Before August 1992)	3-5
3-4	Platform Control Station w/o PQ Controller - CM2033/CM2046/CM2546/CM2558 (Machines Built After August 1992)	3-6
3-5	Platform Control Station w/PQ Controller - CM2033/CM2046/CM2546/CM2558 (Machines Built After August 1992)	3-6
4-1	Grade and Sideslope	4-3
7-1	Torque Chart	7-3
7-2	Lubrication Chart	7-4
7-3	Serial Number Locations	7-6
8-1	Poly-Pak Seal Installation	8-7
8-2	Brake Cylinder Assembly	8-10
8-3	Tilt Alarm Switch Leveling - Voltmeter Adjustment	8-12
8-4	Pressure Adjustment Locations - Proportional Valve	8-13
8-5	Pressure Adjustment Locations - Bang-Bang Valve	8-14
11-1-1	Frame, Steering and Drive Installation	11-1-2
11-1-2	Drive Motor Assemblies	11-1-8
11-1-3	Rear Axle and Brake Installations (Prior to March 1992)	11-1-10
11-1-4	Rear Axle and Brake Installations (March 1992 to Present)	11-1-14
11-1-5	Frame Mounted Components Installation	11-1-16
11-2-1	Covers, Controls, Tank and Valves Installation	11-2-2
11-2-2	Control Valve Assembly - Hydro-Air (Machines with Bang-Bang Drive Built Prior to June 1992)	11-2-8
11-2-3	Control Valve Assembly - Hydro-Air (Machines with Bang-Bang Drive Built June 1992 to Present)	11-2-12
11-2-4	Control Valve Assembly - Hydro-Air (Machines with Proportional Drive)	11-2-16
11-2-5	Control Valve Assembly (Hydraulically Extended Deck Option)	11-2-20
11-2-6	Batteries and Chargers Installation	11-2-22
11-2-7	Battery Charger Assembly	11-2-26
11-2-8	UL Listed Components Installation - Ground Components	11-2-28
11-3-1	Sizzor Arms Installation - CM2033 and CM2046	11-3-2
11-3-2	Sizzor Arms Installation - CM2546 and CM2558	11-3-4
11-4-1	Standard Handrails and Accessories Installation	11-4-2
11-4-2	Optional Fold-Down Handrail Installation	11-4-8
11-4-3	Optional Extendable Deck Installation with Standard Handrails	11-4-12
11-4-4	Optional Extendable Deck Installation with Fold-Down Handrails	11-4-14
11-4-5	Optional Hydraulically Extended Deck Installation with standard Handrails	11-4-16
11-4-5A	Optional Hydraulically Extended Deck Installation with Fold-Down Handrails	11-4-18
11-4-6	Steel Platform Console Box Assembly	11-4-20
11-4-7	Molded Platform Console Box Assembly	11-4-24
11-5-1	Brake Cylinder Assembly (Prior to March 1992)	11-5-2

LIST OF ILLUSTRATIONS (cont.)

FIGURE NO.	TITLE	PAGE NO.
11-5-2	Brake Cylinder Assembly (March 1992 to Present)	11-5-4
11-5-3	Lift Cylinder Sub-Assembly	11-5-6
11-5-4	Platform Extension Cylinder Assembly (Hydraulically Extended Deck Option)	11-5-10
11-5-5	Steer Cylinder Assembly	11-5-12
11-6-1	Hydraulic Diagram - Bang-Bang Drive	11-6-2
11-6-2	Hydraulic Diagram - Proportional Drive	11-6-6
11-7-2	Electrical Diagram - Toggle Switch Drive	11-7-10
11-7-3	Electrical Diagram - PQ Controller Bang-Bang Drive	11-7-11
11-7-4	Electrical Diagram - PQ Controller Proportional Drive	11-7-12
11-7-5	Electrical Diagram - Circuit Cards	11-7-13
11-7-6	Main Electrical Connector and Tools	11-7-14
11-8-1	Decal Installation - Domestic	11-8-2
11-8-2	Decal Installation - Latin American	11-8-6

LIST OF TABLES

TABLE NO.	TITLE	PAGE NO.
3-1	Control Panel Symbols	3-7
7-1	Hydraulic Oil	7-2
7-2	Lubrication Specifications	7-2
8-1	Cylinder Piston Nut Torque Specifications	8-8
8-2	Holding Valve Torque Specifications	8-8
8-3	Preventive Maintenance and Inspection	8-17
9-1	Elevation System Troubleshooting	9-2
9-2	Chassis Troubleshooting	9-4
9-3	Hydraulic System Troubleshooting	9-8
9-4	Electrical System Troubleshooting	9-9

1-1. GENERAL.

- a. This section prescribes the proper and safe practices for major areas of machine usage which have been divided into three basic categories: Driving, Operation and Maintenance. In order to promote proper usage of the machine, it is mandatory that a daily routine be established based on instruction given in this section. A maintenance program must also be established by a qualified person and must be followed to ensure that the machine is safe to operate.
- b. The user/operator of the machine should not accept operating responsibility until this manual has been read and operation of the machine, under the supervision of an experienced and qualified operator, has been completed. If there is a question on application and/or operation, JLG Industries Product Safety and Reliability should be consulted.

WARNING

MODIFICATION OF THE MACHINE WITHOUT APPROVAL OF JLG INDUSTRIES, OR CERTIFICATION BY A NATIONALLY RECOGNIZED TESTING LAB TO BE IN CONFORMITY WITH APPLICABLE OSHA REGULATIONS, AND TO BE AT LEAST AS SAFE AS BEFORE MODIFICATION, IS PROHIBITED AND IS A VIOLATION OF OSHA RULES.

1-2. DRIVING/TOWING/CARRYING.

- a. Before driving the machine the user must be familiar with the drive, steer and stopping characteristics. This is especially important when driving in close quarters.
- b. The user should be familiar with the driving surface before driving. The surface should be firm and level and grades should not exceed the allowable grade, as indicated on the CAUTION placard at the platform control station.

Note

Remember that the key to safe and proper usage is common sense and its careful application.

- c. Standard machine is not equipped with provisions for towing. Refer to Section 6 for emergency towing procedures.

SPECIAL NOTE:

CERTAIN 'CARTOONS' IN THIS PUBLICATION SHOULD IN NO WAY BE CONSTRUED AS SHOWING THE PROPER USE OF THE MACHINES. THEY ARE INCLUDED TO PROVIDE VISUAL INDICATIONS OF INCORRECT EQUIPMENT OPERATION AND APPLICATION.

WARNING

FAILURE TO COMPLY WITH SAFETY PRECAUTIONS LISTED IN THIS SECTION AND ON MACHINE MAY RESULT IN MACHINE DAMAGE, PERSONNEL INJURY OR DEATH AND IS A SAFETY VIOLATION.

- d. Carrying or loading the unit should be accomplished using a forklift vehicle of suitable capacity with the forks being positioned correctly beneath the indicated areas on the lower side of the frame.

1-3. ELECTROCUTION HAZARD.

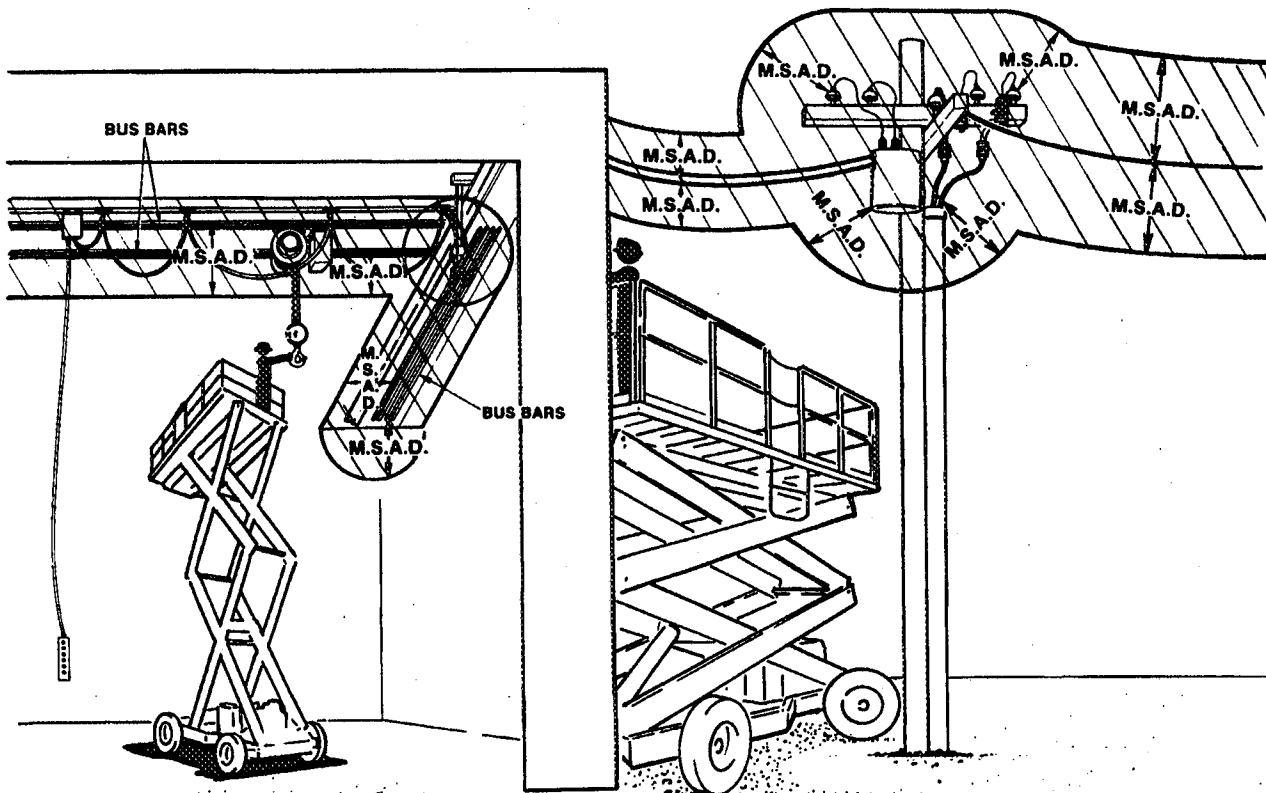

DENOTES PROHIBITED ZONE

M.S.A.D. = MINIMUM SAFE APPROACH DISTANCE
 (SEE TABLE BELOW)
 MAINTAIN M.S.A.D. FROM ALL
 OTHER CHARGED LINES AND PARTS
 AS WELL AS THOSE SHOWN.

Table

Minimum safe approach distances (M.S.A.D.) to energized (exposed or insulated) power lines and parts.

VOLTAGE RANGE (Phase to Phase)	MINIMUM SAFE APPROACH DISTANCE Feet (Meters)
0 to 300V	AVOID CONTACT
Over 300V to 50KV	10 (3)
Over 50KV to 200KV	15 (5)
Over 200KV to 350KV	20 (6)
Over 350KV to 500KV	25 (8)
Over 500KV to 750KV	35 (11)
Over 750KV to 1000KV	45 (14)

DANGER: DO NOT manuever machine or personnel inside **PROHIBITED ZONE**.
ASSUME all electrical parts and wiring are **ENERGIZED** unless known otherwise.

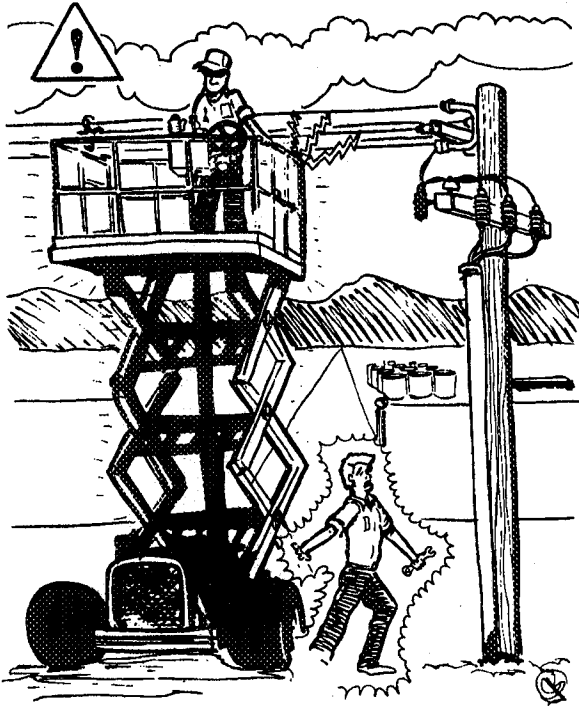

MAINTAIN A SAFE DISTANCE FROM ELECTRICAL LINES AND APPARATUS.

MAINTAIN SAFE CLEARANCE FROM ELECTRICAL LINES AND APPARATUS. ALLOW FOR PLATFORM SWAY, ROCK OR SAG AND ELECTRICAL LINE SWAYING. THE MACHINE DOES NOT PROVIDE PROTECTION FROM CONTACT WITH OR PROXIMITY TO AN ELECTRICALLY CHARGED CONDUCTOR.

MAINTAIN A CLEARANCE OF AT LEAST 10 FEET (3 M) BETWEEN ANY PART OF THE MACHINE OR ITS LOAD AND ANY ELECTRICAL LINE OR APPARATUS CARRYING UP TO 50,000 VOLTS. ONE FOOT (0.3 M) ADDITIONAL CLEARANCE IS REQUIRED FOR EVERY ADDITIONAL 30,000 VOLTS OR LESS.

1-4. PRE-OPERATIONAL.

READ YOUR MANUAL. UNDERSTAND WHAT YOU'VE READ - THEN BEGIN OPERATIONS.

ALLOW ONLY THOSE AUTHORIZED AND QUALIFIED PERSONNEL TO OPERATE MACHINE WHO HAVE DEMONSTRATED THAT THEY UNDERSTAND SAFE AND PROPER OPERATION AND MAINTENANCE OF THE UNIT.

AN OPERATOR MUST NOT ACCEPT OPERATING RESPONSIBILITIES UNTIL ADEQUATE TRAINING HAS BEEN GIVEN BY COMPETENT AND AUTHORIZED PERSONS.

BEFORE OPERATION CHECK WORK AREA FOR BARE OVERHEAD ELECTRIC LINES, MACHINE TRAFFIC SUCH AS BRIDGE CRANES, HIGHWAY, RAILWAY AND CONSTRUCTION EQUIPMENT.

PRECAUTIONS TO AVOID ALL KNOWN HAZARDS IN THE WORK AREA MUST BE TAKEN BY THE OPERATOR AND HIS SUPERVISOR BEFORE STARTING THE WORK.

DO NOT OPERATE THIS MACHINE UNLESS IT HAS BEEN SERVICED AND MAINTAINED ACCORDING TO THE MANUFACTURERS SPECIFICATIONS AND SCHEDULE.

ENSURE DAILY INSPECTION AND FUNCTION CHECK IS PERFORMED PRIOR TO PLACING MACHINE INTO OPERATION.

NEVER DISABLE OR MODIFY ANY SAFETY DEVICE. ANY MODIFICATION OF THE MACHINE IS A SAFETY VIOLATION AND IS A VIOLATION OF OSHA RULES.

DO NOT OPERATE MACHINE WHEN WIND CONDITIONS EXCEED 30 MPH.

NEVER OPERATE OR RAISE PLATFORM WHEN MACHINE IS ON A TRUCK OR OTHER VEHICLE.

APPROVED HEAD GEAR MUST BE WORN WHEN REQUIRED BY ALL OPERATING AND GROUND PERSONNEL.

READ AND OBEY ALL WARNINGS, CAUTIONS AND OPERATING INSTRUCTIONS ON MACHINE AND IN THIS MANUAL.

BE FAMILIAR WITH LOCATION AND OPERATION OF GROUND STATION CONTROLS.

ALWAYS USE 'THREE POINT CONTACT' WITH THE MACHINE. FACE THE MACHINE WHEN ENTERING OR LEAVING THE PLATFORM. 'THREE POINT CONTACT' MEANS THAT TWO HANDS AND ONE FOOT OR ONE HAND AND TWO FEET ARE IN CONTACT WITH THE MACHINE AT ALL TIMES DURING MOUNT AND DISMOUNT.

1-5. DRIVING.

WATCH FOR OBSTRUCTIONS AROUND MACHINE AND OVERHEAD WHEN DRIVING.

CHECK TRAVEL PATH FOR PERSONS, HOLES, BUMPS, DROP-OFFS, OBSTRUCTIONS, DEBRIS, AND COVERINGS WHICH MAY CONCEAL HOLES AND OTHER HAZARDS.

WHEN DRIVING IN HIGH SPEED, SWITCH TO LOW BEFORE STOPPING. TRAVEL GRADES IN LOW DRIVE ONLY.

DO NOT DRIVE ON GRADES AND SIDESLOPES EXCEEDING THOSE INDICATED ON CAUTION PLACARD AT MACHINE PLATFORM.

BEFORE DRIVING ON FLOORS, BRIDGES, TRUCKS AND OTHER SURFACES, CHECK ALLOWABLE CAPACITY OF SURFACES.

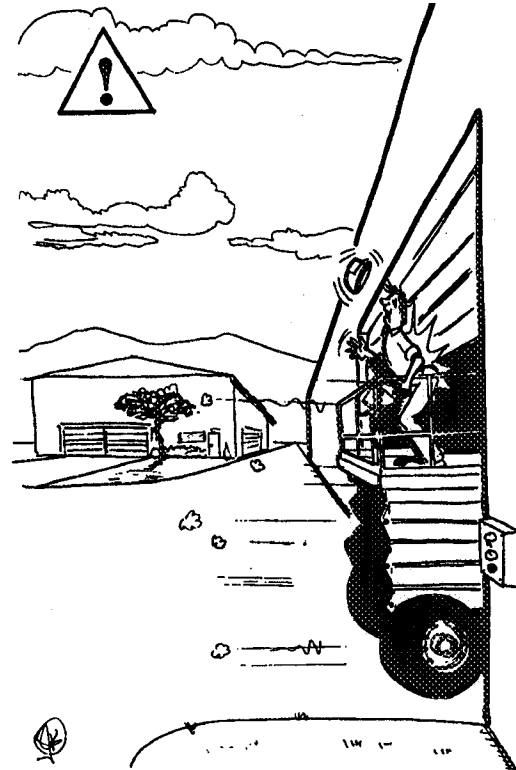

ALWAYS LOOK IN THE DIRECTION OF TRAVEL.

DO NOT TRAVEL ON SOFT OR UNEVEN SURFACES, AS TIPPING WILL OCCUR.

DO NOT USE HIGH SPEED DRIVE IN RESTRICTED OR CLOSE QUARTERS OR WHEN DRIVING IN REVERSE.

BE AWARE OF STOPPING DISTANCES WHEN TRAVELING IN HIGH AND LOW SPEEDS.

ALWAYS POST A LOOKOUT AND SOUND HORN WHEN DRIVING IN AREAS WHERE VISION IS OBSTRUCTED.

KEEP NON-OPERATING PERSONNEL AT LEAST 6 FEET (1.8 M) AWAY FROM MACHINE DURING DRIVING OPERATIONS.

1-6. OPERATION.

READ YOUR MANUAL, UNDERSTAND WHAT YOU'VE READ - THEN BEGIN OPERATIONS.

DO NOT OPERATE ANY MACHINE ON WHICH DANGER, WARNING, CAUTION OR INSTRUCTION PLACARDS OR DECALS ARE MISSING OR ILLEGIBLE.

MACHINE MUST ALWAYS BE SHUT DOWN WHEN REFUELING. 'NO SMOKING' IS MANDATORY. NEVER REFUEL DURING AN ELECTRICAL STORM. ENSURE THAT FUEL CAP IS CLOSED AND SECURE AT ALL OTHER TIMES.

NEVER EXCEED MANUFACTURERS RATED PLATFORM CAPACITY - REFER TO CAPACITY DECAL ON MACHINE. DISTRIBUTE LOAD EVENLY ON PLATFORM FLOOR.

ENSURE MACHINE IS POSITIONED ON A FIRM, LEVEL AND UNIFORM SURFACE BEFORE RAISING PLATFORM.

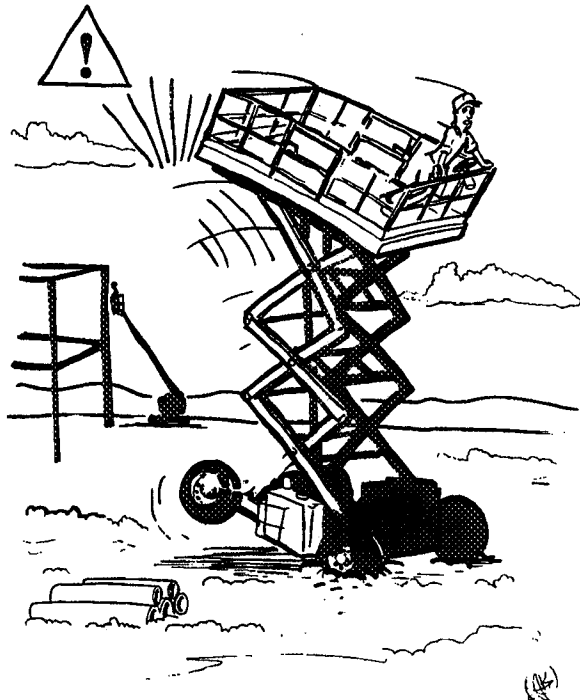

NEVER OPERATE ON SOFT OR UNEVEN SURFACES.

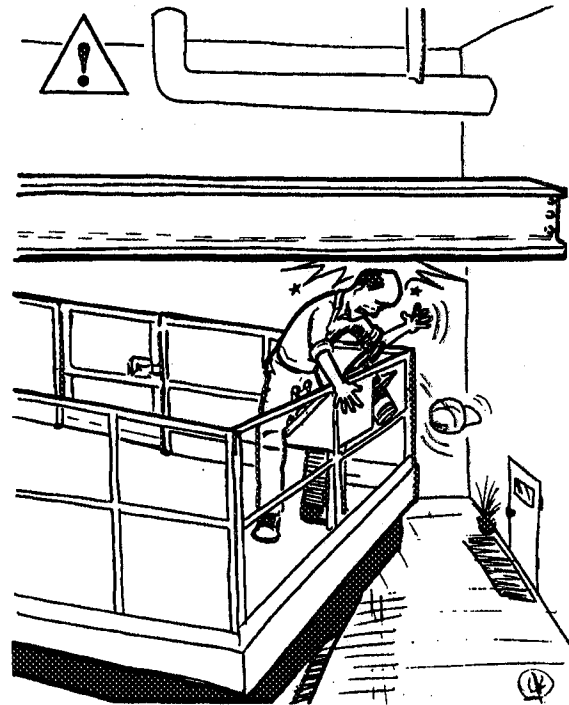

THOROUGHLY CHECK ALL CLEARANCES BEFORE POSITIONING PLATFORM.

NEVER 'SLAM' A CONTROL SWITCH OR LEVER THROUGH NEUTRAL TO OPPOSITE DIRECTION. ALWAYS RETURN SWITCH TO NEUTRAL AND STOP; THEN MOVE SWITCH TO THE DESIRED POSITION. OPERATE LEVERS WITH SLOW, EVEN PRESSURE.

NEVER OPERATE A MALFUNCTIONING MACHINE. IF A MALFUNCTION OCCURS, SHUT DOWN THE MACHINE, RED TAG IT, AND NOTIFY PROPER AUTHORITIES.

CHECK CLEARANCES ABOVE, ON SIDES AND BOTTOM OF PLATFORM WHEN RAISING AND LOWERING PLATFORM.

NEVER USE SIZZOR ARMS TO GAIN ACCESS TO OR LEAVE PLATFORM.

DO NOT ATTACH OVERHANGING LOADS TO THE PLATFORM OR INCREASE THE PLATFORM SIZE WITH UNAUTHORIZED DECK EXTENSIONS OR ATTACHMENTS.

DO NOT ELEVATE PLATFORM WHILE DRIVING, OR UNLESS MACHINE IS LEVEL.

DO NOT TIE OFF MACHINE TO ANY ADJACENT STRUCTURE. NEVER ATTACH WIRE, CABLE OR ANY SIMILAR ITEMS TO PLATFORM.

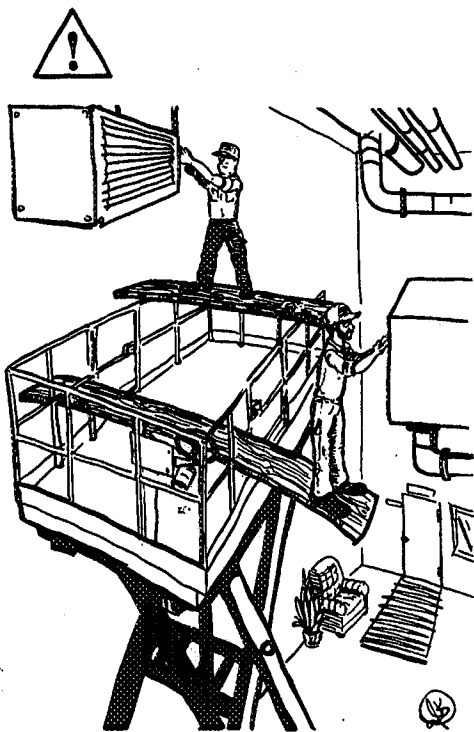

ALWAYS STAND ON PLATFORM FLOOR, NOT ON BOXES, PLANKS OR RAILINGS.

DURING ENTRY OR EXIT ABOVE GROUND OSHA REQUIRES THAT SAFETY BELT BE ATTACHED TO THE STRUCTURE BEING ENTERED.

TO AVOID FALLING - USE EXTREME CAUTION WHEN ENTERING OR LEAVING PLATFORM ABOVE GROUND. ENTER OR EXIT THRU GATE ONLY. PLATFORM MUST BE WITHIN 1 FOOT (0.3 M) OF ADJACENT - SAFE AND SECURE - STRUCTURE.

NO STUNT DRIVING OR HORSEPLAY IS PERMITTED.

DO NOT ALLOW PERSONNEL TO TAMPER WITH, SERVICE, OR OPERATE THIS MACHINE FROM THE GROUND WITH PERSONNEL IN PLATFORM EXCEPT IN AN EMERGENCY.

WHEN TWO OR MORE PERSONS ARE IN PLATFORM, THE OPERATOR SHALL BE RESPONSIBLE FOR ALL MACHINE OPERATIONS.

DURING OPERATION KEEP ALL BODY PARTS INSIDE PLATFORM RAILINGS.

NEVER POSITION LADDERS, STEPS, OR SIMILAR ITEMS ON UNIT TO PROVIDE ADDITIONAL REACH FOR ANY PURPOSE.

WHEN RIDING IN OR WORKING FROM PLATFORM BOTH FEET MUST BE FIRMLY POSITIONED ON DECK.

DO NOT EXTEND REACH LIMITS OF THIS MACHINE WITH ADDITIONAL EQUIPMENT SUCH AS PLANKS, BOXES, ETC.

OBSERVE EXTREME CAUTION AT ALL TIMES TO PREVENT OBSTACLES FROM STRIKING OR INTERFERING WITH OPERATING CONTROLS AND PERSONS IN THE PLATFORM.

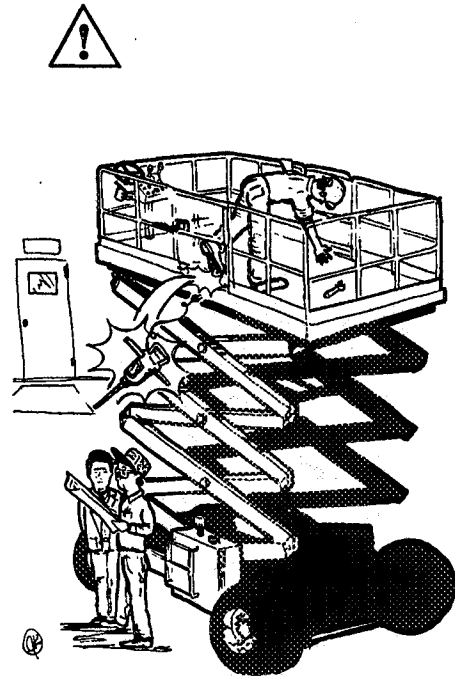

KEEP EVERYONE CLEAR OF A WORKING PLATFORM.

ENSURE THAT OPERATORS OF OTHER OVERHEAD AND FLOOR LEVEL MACHINES ARE AWARE OF THE AERIAL PLATFORMS PRESENCE. DISCONNECT POWER TO OVERHEAD CRANES. BARRICADE FLOOR AREA IF NECESSARY.

DO NOT OPERATE WITHOUT HANDRAILS IN PLACE AND SECURED. IT IS A SAFETY VIOLATION.

DO NOT STEP OUTSIDE OF HANDRAILS.

ALWAYS ENSURE THAT POWER TOOLS ARE PROPERLY STOWED AND NEVER LEFT HANGING BY THEIR CORD FROM THE PLATFORM WORK AREA.

AVOID ACCUMULATION OF DEBRIS ON PLATFORM WORK AREA. KEEP MUD, OIL, GREASE AND OTHER SLIPPERY SUBSTANCES FROM FOOTWEAR AND PLATFORM DECK.

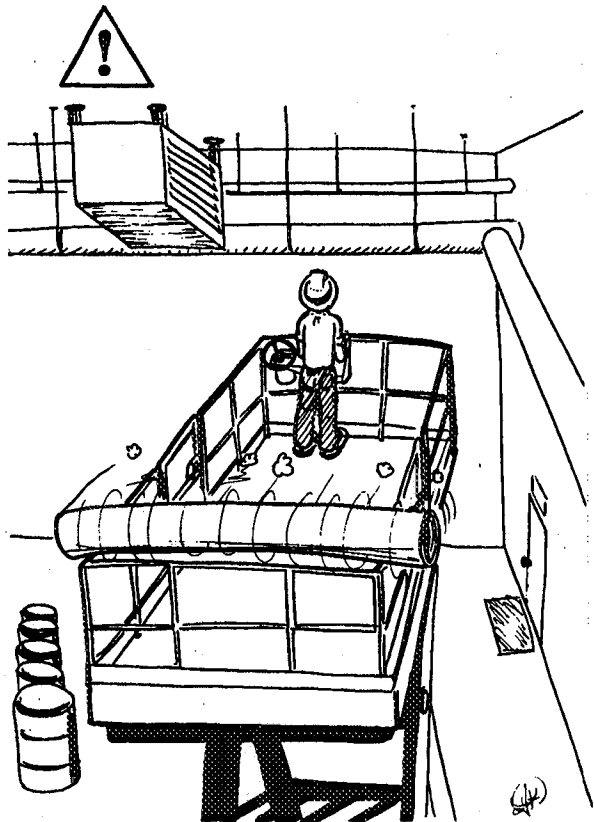

PLATFORM RAILS ARE NOT FOR HANDLING MATERIAL.

1-7. TOWING AND HAULING.

NEVER ATTEMPT TO TOW OR PULL MACHINE. ALWAYS CARRY MACHINE WITH FORKLIFT OF SUITABLE CAPACITY.

HAVE PLATFORM COMPLETELY EMPTY OF TOOLS AND DEBRIS BEFORE CARRYING.

WHEN LIFTING MACHINE, POSITION FORKS ONLY AT DESIGNATED AREA AT REAR OF MACHINE.

HAVE PLATFORM FULLY RETRACTED WHILE MACHINE IS BEING CARRIED.

NEVER ALLOW PERSONNEL IN PLATFORM WHILE CARRYING.

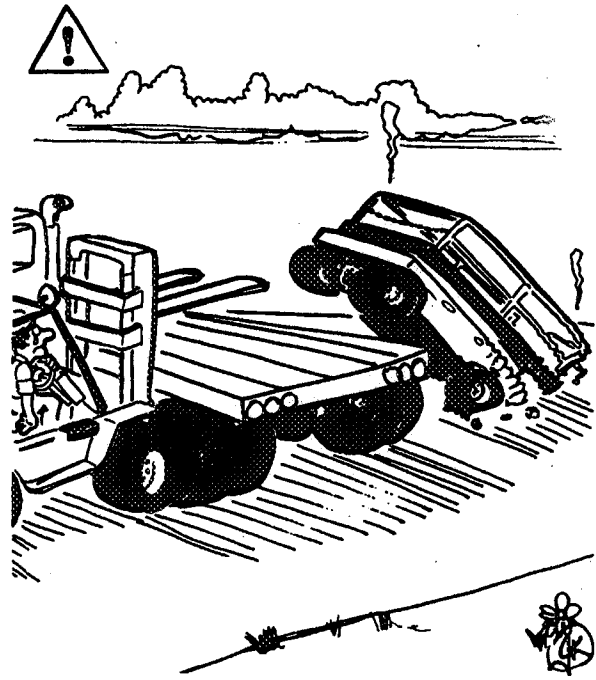

LIFT MACHINE AT DESIGNATED AREA ONLY..

1-8. MAINTENANCE.

- a. This section contains the general safety precautions which must be observed during maintenance of the aerial platform. It is of utmost importance that maintenance personnel pay strict attention to these warnings and precautions to avoid possible injury to themselves or others or damage to the equipment. A maintenance program must be established by a qualified person and must be followed to ensure that the machine is safe to operate.

WARNING

MODIFICATION OF THE MACHINE WITHOUT CERTIFICATION BY A RESPONSIBLE AUTHORITY THAT THE MACHINE IS AT LEAST AS SAFE AS ORIGINALLY MANUFACTURED IS A SAFETY VIOLATION.

- b. The specific precautions to be observed during machine maintenance are inserted at the appropriate point in the manual. These precautions are, for the most part, those that apply when servicing hydraulic and larger machine component parts.
- c. Your safety, and that of others, is the first consideration when engaging in the maintenance of equipment. Always be conscious of weight.

Never attempt to move heavy parts without the aid of a mechanical device. Do not allow heavy objects to rest in an unstable position. When raising a portion of the equipment, ensure that adequate support is provided.

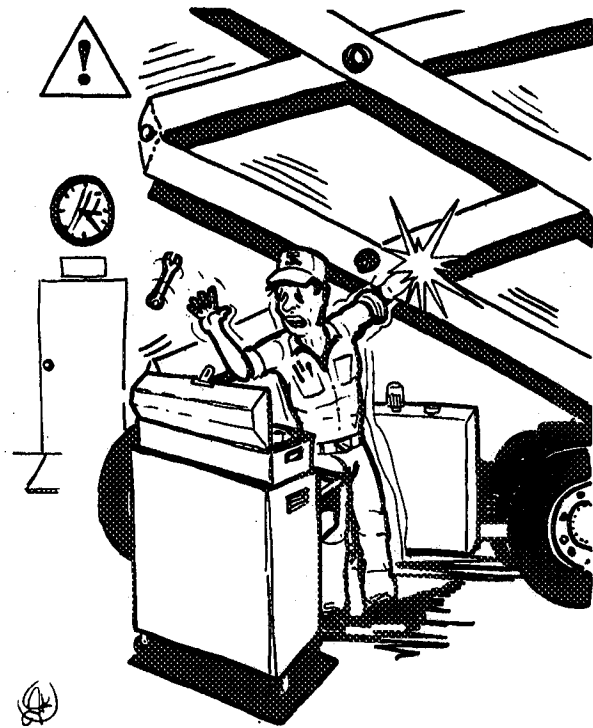

USE SAFETY PROPS WHEN PERFORMING MAINTENANCE.

ALWAYS DISCONNECT BATTERIES WHEN REPLACING ELECTRICAL COMPONENTS.

REMOVE RINGS, WATCHES AND JEWELRY WHEN PERFORMING ANY MAINTENANCE.

DO NOT WEAR LOOSE FITTING CLOTHING OR LONG HAIR UNRESTRAINED, WHICH IS APT TO BECOME CAUGHT ON, OR ENTANGLED IN EQUIPMENT.

USE ONLY CLEAN APPROVED NONFLAMMABLE CLEANING SOLVENTS.

SHUT OFF ALL POWER CONTROLS BEFORE MAKING ADJUSTMENTS, LUBRICATING OR PERFORMING ANY OTHER MAINTENANCE.

NEVER WORK UNDER AN ELEVATED PLATFORM UNTIL IT HAS BEEN RESTRAINED FROM MOVEMENT WITH SAFETY PROPS, BLOCKING OR OVERHEAD SLING.

NEVER ALTER, REMOVE OR SUBSTITUTE ANY ITEM SUCH AS COUNTERWEIGHTS, FOAM FILLED TIRES, BATTERIES, ETC. WHICH WOULD REDUCE THE OVERALL WEIGHT OR BASE STABILITY OF THE MACHINE.

2-1. GENERAL.

This section provides the necessary information needed by those personnel that are responsible to place the machine in operation readiness, and lists checks that are performed prior to use of the machine. It is important that the information contained in this section be read and understood before any attempt is made to operate the machine. Ensure that all the necessary inspections have been completed successfully before placing the machine into service. These procedures will aid in obtaining maximum service life and safe operation.

IMPORTANT

SINCE THE MACHINE MANUFACTURER HAS NO DIRECT CONTROL OVER THE FIELD INSPECTION AND MAINTENANCE, SAFETY IS THE RESPONSIBILITY OF THE OWNER/OPERATOR.

2-2. PREPARATION FOR USE.

- a. Before a new machine is put into operation it must be carefully inspected for any evidence of damage resulting from shipment and inspected periodically thereafter, as outlined in paragraph 2-3, Delivery and Periodic Inspection. The unit should be thoroughly checked for hydraulic leaks during initial start-up and run. A check of all components should be made to assure their security.
- b. All preparation necessary to place the machine in operation readiness status are the responsibility of management personnel. Preparation requires good common sense, (i.e. lift works smoothly and brakes operate properly) coupled with a series of visual inspections. The mandatory requirements are given in paragraph 2-4, Daily Walk Around Inspection.
- c. It should be assured that the items appearing in the Delivery and Periodic Inspection and Functional Check are complied with prior to putting the machine into service.

2-3. DELIVERY AND PERIODIC INSPECTION.

Note

This machine requires periodic safety and maintenance inspections by a JLG Dealer. A decal located on the frame provides a place to record (stamp) inspection dates. Check decal and notify dealer if inspection is overdue.

- a. The following checklist provides a systematic inspection to assist in detecting defective, damaged, or improperly installed parts. The checklist denotes the items to be inspected and conditions to examine. Periodic inspection shall be performed monthly or more often when required by environment, severity, and frequency of usage.

- (1). Handrail Assemblies.

Properly installed; no loose or missing parts; no visible damage.

- (2). Platform Assembly.

No visible damage; free of dirt and debris.

- (3). Sizzor Arms.

No visible damage, abrasions and/or distortions.

- (4). Electrical Cable.

No visible damage; properly secured.

- (5). Pivot Pins.

No loose or missing retaining hardware; no damage or wear to pin heads which would cause pin to rotate; no evidence of pin or bushing wear.

- (6). Lift Cylinder.

No rust, nicks, scratches or foreign material on piston rod. No leakage. Evidence of proper lubrication.

- (7). Frame.

No visible damage; loose or missing hardware (top and underside).

- (8). Tire and Wheel Assemblies.

No loose or missing lug nuts; no visible damage.

- (9). Sliding Wear Pad Blocks.

No excessive wear; adequate lubrication.

- (10). Hydraulic Oil Supply.

Note

Prior to checking the hydraulic oil level, operate the machine through one complete cycle of the lift function (full up and down). Failure to do so will result in an incorrect oil level reading on the hydraulic tank.

Level should be at full mark on side of hydraulic tank (all systems shut down, ma-

chine in stowed position) immediately after up-down cycle.

(11). Steer Cylinder.

No rust, nicks, scratches or foreign material on piston rod; no leakage.

(12). Steer Linkage.

No loose or missing parts; no visible damage.

(13). Front Spindle Assemblies.

No excessive wear; no damage.

(14). Control Boxes. (Console and Ground)

Switches operable; no visible damage; placards secure and legible. If equipped, controller operable; no visible damage.

(15). Batteries.

Proper electrolyte level; cable connections tight; no visible damage; no corrosion at battery cable connections.

(16). Hydraulic Pump and Valves.

No leakage; units secure.

(17). Platform Placards.

No visible damage; placards secure and legible.

2-4. DAILY WALK-AROUND INSPECTION.

- a. It is the user's responsibility to inspect the machine before the start of each workday. It is recommended that each user inspect the machine before operation, even if the machine has already been put into service under another user. This Daily Walk-Around Inspection is the preferred method of inspection. (See Figure 2-1.)
- b. In addition to the Daily Walk-Around Inspection, be sure to include the following as part of the daily inspection:
 - (1). Overall Cleanliness.

Check all standing surfaces for oil, fuel and hydraulic oil spillage and foreign objects. Ensure overall cleanliness.

(2). Placards.

Keep all information and operating placards clean and unobstructed. Cover when

spray painting or shot blasting to protect legibility.

(3). Operators, Service, and Parts Manual.

Ensure a copy of this manual is enclosed in the manual storage box.

(4). Machine Log.

Ensure a machine operating record or log is kept. Check to see that it is current and that no entries have been left uncleaned, leaving machine in an unsafe condition for operation.

(5). Daily Lubrication.

For those items pointed out in the Daily Walk-Around Inspection requiring daily lubrication, refer to the Lubrication Chart, Figure 7-2, for specific requirements.

- c. Perform the following checks and services before attempting to operate the machine.

WARNING

TO AVOID INJURY DO NOT OPERATE A MACHINE UNTIL ALL MALFUNCTIONS HAVE BEEN CORRECTED. USE OF A MALFUNCTIONING MACHINE IS A SAFETY VIOLATION.

- (1). Start each day with fully charged batteries.
- (2). Ensure that all items requiring lubrication are serviced in accordance with the Lubrication Chart, Figure 7-2.
- (3). Perform functional checks in accordance with paragraph 2-5, Daily Functional Check.

2-5. DAILY FUNCTIONAL CHECK.

WARNING

TO AVOID INJURY DO NOT OPERATE A MACHINE UNTIL ALL MALFUNCTIONS HAVE BEEN CORRECTED. USE OF A MALFUNCTIONING MACHINE IS A SAFETY VIOLATION.

- a. A functional check of all systems should be performed, under no load, once the walk-around inspection is complete, in an area free of overhead and ground level obstructions. Perform pre-load functional check in accordance with the following procedure:
 - (1). Raise and lower platform several times. Check for smooth elevation and lowering. Check for High Drive cut-out as platform begins to raise.

- (2). Drive forward and reverse, check for proper operation.
- (3). Check that drive brake holds when machine is driven up a hill, not to exceed rated gradeability, and stopped.
- (4). Steer left and right. Check for proper operation.
- (5). Check hydraulic oil reservoir dipstick. Refer to Lubrication Chart.

2-6. TORQUE REQUIREMENTS.

The Torque Chart, Figure 7-1, consists of standard torque values based on bolt diameter and grade, also specifying dry and wet torque values in accordance with recommended shop practices. This chart is provided as an aid to the operator in the event he/she notices a condition that requires prompt attention during the walk-around inspection or during operation until the proper service personnel can be notified. Section 7 provides specific torque values and periodic maintenance procedures with a listing of individual components. Utilizing this Torque Chart in conjunction with the preventive maintenance section in Section 8, will enhance safety, reliability and performance of the machine.

2-7. BATTERY CHARGING.

At the end of the work day, the batteries should be charged for the next days work. Position the Emergency Stop switch to OFF. Prior to charging, be sure electrolyte covers plates. Connect the battery charger to a properly grounded 110 Volt receptacle using a suitable extension cord. Set the battery charger timer switch, if equipped, for the desired charging time. After charging, check the electrolyte level of the batteries and adjust accordingly. Add distilled water only to batteries. A fully charged battery will have a specific gravity of between 1.260 - 1.275 on a hydrometer.

CAUTION

WHEN ADDING DISTILLED WATER TO THE BATTERIES, A NON-METALLIC CONTAINER AND/OR FUNNEL MUST BE USED. ADD WATER ONLY TO LEVEL INDICATOR OR 3/8 INCH (0.95 CM) ABOVE SEPARATORS.

NO OPEN FLAMES OR SMOKING WHEN CHARGING BATTERIES.

CHARGE BATTERIES ONLY IN A WELL VENTILATED AREA.

ENSURE THAT BATTERY ACID DOES NOT COME INTO CONTACT WITH SKIN OR CLOTHING.

Notes

Be sure to disconnect and store any extension cords after charging batteries and before putting machine into service.

To avoid electrolyte overflow, add distilled water to batteries after charging.

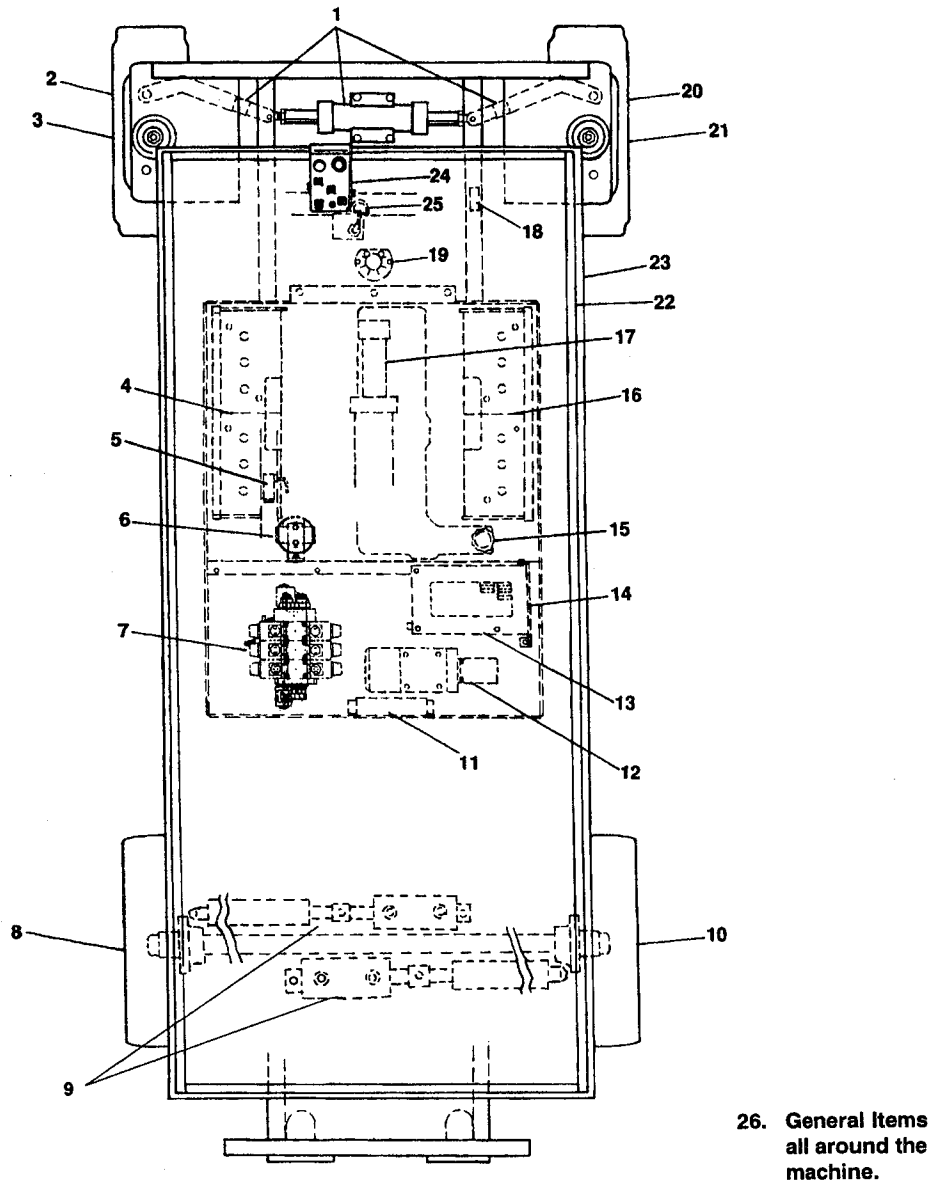

26. General Items all around the machine.

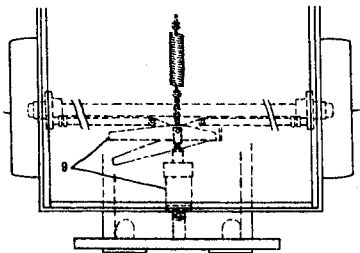

Insert A. Parking Brake -
Machines Built Before March 1992.

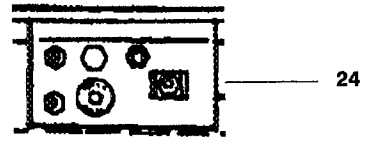

Insert B. Platform Control Box -
Machines Built Before August 1992.

Figure 2-1. Daily Walk-Around Inspection. (Sheet 1 of 2)

GENERAL.

Begin the "Walk-Around Inspection" at Item 1, as noted on the diagram. Continue to the right (counterclockwise viewed from top) checking each item in sequence for the conditions listed in the "Walk-Around Inspection Checklist".

WARNING

TO AVOID INJURY DO NOT OPERATE MACHINE UNTIL ALL MALFUNCTIONS HAVE BEEN CORRECTED. USE OF A MALFUNCTIONING MACHINE IS A SAFETY VIOLATION.

TO AVOID POSSIBLE INJURY, BE SURE MACHINE POWER IS "OFF" DURING "WALK-AROUND INSPECTION".

Note

Do not overlook visual inspection of chassis underside. Checking this area often results in discovery of conditions which could cause extensive machine damage.

1. Steer Cylinder and Linkage - No loose or missing parts, no visible damage. No steer cylinder leaks or damage.
2. Steer/Drive Wheel and Tire Assembly, Left Front - Properly secured, no loose or missing lug nuts, no visible damage.
3. Drive Motor, Left Front - No visible damage, no evidence of leakage.
4. Battery Installation - Proper electrolyte level, cables secure, no damage or corrosion. Holddowns secure.
5. Limit Switch - Properly secured, no visible damage.
6. Hydraulic Filter - No visible damage, properly secured, no evidence of leakage.
7. Control Valve Installation - No loose or missing parts, no evidence of leakage. No unsupported wires or hoses, no damaged or broken wires.
8. Wheel and Tire Assembly, Left Rear - Properly secured, no loose or missing lug nuts, no visible damage.
9. Parking Brake - No loose or missing parts, no visible damage. No cylinder leaks.
10. Wheel and Tire Assembly, Right Rear - Properly secured, no loose or missing lug nuts, no visible damage.
11. Cushion Cylinder - Properly secured, no visible damage, no evidence of leakage.
12. Motor/Pump Unit - Properly secured, no visible damage, no evidence of hydraulic leaks.
13. Battery Charger - No damage, properly secured.
14. Ground Controls - Switches operable, no visible damage, placards secure and legible.
15. Hydraulic Reservoir - No visible damage or missing parts, no evidence of leaks. Recommended hydraulic fluid level on dipstick. (Cut fluid, system shut down, machine in stowed position.) Breather cap secure and working.
16. Battery Installation - Proper electrolyte level, cables secure, no damage or corrosion. Holddowns secure.
17. Lift Cylinder - Properly secured, no visible damage, no loose or missing parts, no evidence of leakage.
18. Sizzor Arms and Sliding Wear Pads - Properly secured, no visible damage, evidence of proper lubrication. Inspect sizzor arm guards for damage and proper installation.
19. Tilt Alarm - Properly secured, no loose or missing parts, no visible damage.
20. Steer/Drive Wheel and Tire Assembly, Right Front - Properly secured, no loose or missing lug nuts, no visible damage.
21. Drive Motor, Right Front - No visible damage, no evidence of leakage.
22. Handrail Installation - All railings securely attached, no visible damage, no missing parts, chain in proper working order.
23. Platform Assembly - No loose or missing parts, no visible damage, platform deck extension operates properly.
24. Platform Controls - Properly secured, no loose or missing parts, no visible damage. Placards secure and legible, control switches return to neutral. Control markings legible, manual in manual storage box.
NOTE: Platform Control Box on machines built after October 1992 shown; see insert A for Platform Control Box on machines built before October 1992.
25. Manual Descent Cable and Pull Ring - Properly secured, no loose or missing parts, no visible damage.
NOTE: Manual Descent handle is shown in location used on machines built until December 1991. Machines built after December 1991 have the Manual Descent Cable located on the left front side of the frame.
26. Valves, Valve Fittings, Hosing and Tubing - properly secured, no loose or missing parts, no visible damage, no evidence of leakage.

Figure 2-1. Daily Walk Around Inspection. (Sheet 2 of 2)

3-1. GENERAL.**IMPORTANT**

SINCE THE MANUFACTURER HAS NO DIRECT CONTROL OVER MACHINE APPLICATION AND OPERATION, CONFORMANCE WITH GOOD SAFETY PRACTICES IN THESE AREAS IS THE RESPONSIBILITY OF THE USER AND HIS OPERATING PERSONNEL.

This section provides the necessary information needed to understand control functions. Included in this section are the operating characteristics and limitations, and functions and purposes of controls and indicators. It is important that the user read and understand the proper procedures before operating the machine. These procedures will aid in obtaining optimum service life and safe operation.

3-2. PERSONNEL TRAINING.

- a. The sizzor lift is a personnel handling device; therefore, it is essential that it be operated and maintained only by authorized personnel who have demonstrated that they understand the proper use and maintenance of the machine. It is important that all personnel who are assigned to and responsible for the operation and maintenance of the machine undergo a thorough training program and check out period in order to become familiar with the characteristics prior to operating the machine.

Persons under the influence of drugs or alcohol or who are subject to seizures, dizziness or loss of physical control must not be permitted to operate the machine.

b. Operator Training.

Operator training must include instruction in the following:

- (1). Use and limitations of the platform controls, ground controls, emergency controls and safety systems.
- (2). Knowledge and understanding of this manual and of the control markings, instructions and warnings on the machine itself.
- (3). Knowledge and understanding of all safety work rules of the employer and of Federal, State and Local Statutes, including training in the recognition and avoidance of potential hazards in the work place; with particular attention to the work to be performed.

- (4). Proper use of all required personnel safety equipment.
- (5). Sufficient knowledge of the mechanical operation of the machine to recognize a malfunction or potential malfunction.
- (6). The safest means to operate near overhead obstructions, other moving equipment, obstacles, depressions, holes, droppos, etc. on the supporting surface.
- (7). Means to avoid the hazards of unprotected electrical conductors.
- (8). Any other requirements of a specific job or machine application.

c. Training Supervision.

Training must be done under the supervision of a qualified operator or supervisor in an open area free of obstructions until the trainee has developed the ability to safely control a sizzor lift in congested work locations.

d. Operator Responsibility.

The operator must be instructed that he has the responsibility and authority to shut down the machine in case of a malfunction or other unsafe condition of either the machine or the job site and to request further information from his supervisor or JLG Distributor before proceeding.

Note

Manufacturer or Distributor will provide qualified persons for training assistance with first unit(s) delivered and thereafter as requested by user or his personnel.

3-3. OPERATING CHARACTERISTICS AND LIMITATIONS.**a. General.**

A thorough knowledge of the operating characteristics and limitations of the machine is always the first requirement for any user, regardless of user's experience with similar types of equipment.

b. Placards.

Important points to remember during operation are provided at the control stations by DANGER, WARNING, CAUTION, IMPORTANT and INSTRUCTION placards. This information is placed at various locations for the express purpose of alerting personnel of potential hazards constituted by the operating characteristics and load limitations of the machine. See foreword for definitions of the above placards.

c. Capacities.

Raising platform above horizontal with or without any load in platform, is based on the following criteria:

- (1). Machine is positioned on a smooth, firm and level surface.
- (2). Load is within manufacturer's rated capacity.
- (3). All machine systems are functioning properly.

d. Stability.

This machine, as originally manufactured by JLG and operated within its rated capacity on a smooth, firm and level supporting surface, provides a stable aerial platform for all platform positions.

3-4. CONTROLS AND INDICATORS.

Some machines may be equipped with control panels that use symbols instead of words to indicate control functions. Refer to Table 3-1 for these symbols and their corresponding functions.

a. Ground Control Station. (Figure 3-1.)

WARNINGS

DO NOT OPERATE FROM GROUND CONTROL STATION WITH PERSONNEL IN THE PLATFORM EXCEPT IN AN EMERGENCY.

PERFORM AS MANY PRE-OPERATIONAL CHECKS AND INSPECTIONS FROM THE GROUND CONTROL STATION AS POSSIBLE.

Note

When the machine is shut down for overnight parking or battery charging, the EMERGENCY STOP switch must be positioned to OFF to prevent draining the batteries.

(1). EMERGENCY STOP Switch.

A two-position, lever operated EMERGENCY STOP switch, when positioned to ON, furnishes operating power to the PLATFORM/GROUND SELECT switch.

(2). POWER SELECTOR Switch.

A three position, key-operated POWER SELECTOR switch supplies operating power to the platform or ground controls, as selected. When positioned to PLATFORM, the switch provides power to the platform controls. When positioned to

GROUND, the switch provides power to the ground controls. With the POWER SELECTOR switch in the center off position, power is shut off to both platform and ground controls.

Notes

With the POWER SELECTOR switch in the OFF position, the key can be removed in order to incapacitate the machine on the jobsite to avoid unauthorized use of the machine.

With the POWER SELECTOR switch positioned to GROUND, engine speed will stay in LOW at all times.

(3). Lift Switch.

A three position, momentary contact LIFT control switch provides raising and lowering of the platform when positioned to UP or DOWN.

(4). Circuit Breaker.

A push button reset 15 Amp circuit breaker, located at the ground control panel, returns interrupted power to the machine functions when depressed.

(5). Powered Deck Extension Switch. (If Equipped)

The machine may be equipped with either a 4 ft. (1.2 m) or 6 ft. (1.8 m) hydraulically powered deck extension. When equipped, a toggle switch mounted on the ground control panel controls deck extension and retraction.

b. Platform Control Station. (Figures 3-2, 3-3, 3-4, and 3-5.)

(1). Enable Switch.

Some machines built before August 1992 and all machines built after August 1992 are equipped with an ENABLE switch on the side of the platform control box. The enable switch must be pressed before activating the DRIVE, LIFT or STEER functions. A built-in timer shuts off power to these functions if they are not activated within 3 seconds after the ENABLE switch is depressed. In addition, this timer will shut off power to the DRIVE and LIFT functions 3 seconds after they are deactivated, making it necessary to depress the ENABLE switch before activating DRIVE or LIFT again. The STEER function, unless activated in conjunction with the DRIVE or LIFT functions, will automatically cut off after 3 seconds of operation.

(2). Emergency Stop Switch.

An EMERGENCY STOP switch is provided in order to turn machine power on and off in the platform and also to turn off machine power in the event of an emergency. Power is turned on by pulling the switch up (ON), and is turned off by pushing the switch down (OFF).

(3). Tilt Alarm Warning Horn. (If Equipped)

The Tilt Alarm Warning Horn is activated by the Tilt Alarm Switch when the chassis is on a severe slope (over 5 degrees).

CAUTION

IF TILT ALARM IS ON WHEN PLATFORM IS RAISED, LOWER PLATFORM COMPLETELY, THEN REPOSITION MACHINE SO THAT IT IS LEVEL BEFORE RAISING PLATFORM.

(4). Tilt Alarm Warning Light. (Red)

A warning light on the control console that lights when the chassis is on a severe slope (over 5 degrees).

Note

The LIFT, DRIVE, and STEER toggle switches automatically return to the center OFF position when released.

WARNING

TO AVOID SERIOUS INJURY, DO NOT OPERATE MACHINE IF LIFT, DRIVE, OR STEER TOGGLE SWITCHES DO NOT RETURN TO THE CENTER OFF POSITION WHEN RELEASED.

(5). Lift Switch.

The LIFT toggle switch provides for raising and lowering the platform when positioned to UP or DOWN.

CAUTION

DO NOT "LIFT DOWN" WITHOUT COMPLETELY RETRACTING PLATFORM EXTENSION.

(6). Positive Traction Switch.

This push button switch, when depressed, activates a solenoid on the main control valve, forcing oil through a flow divider in the drive circuit, maintaining hydraulic oil flow to both drive motors for improved traction.

(7). Steer Switch. (w/o PQ Controller)

The Steer Switch is a three position, center off toggle switch that enables steering the machine to the right or left.

(8). Drive Control Switch. (w/o PQ Controller)

The Drive Control Switch is a three position, center off toggle switch that enables the machine to travel in FORWARD or REVERSE.

(9). Drive Motor Speed Switch. (w/o PQ Controller)

A two position Drive Motor Speed Switch allows additional oil flow to the drive circuit when positioned to HIGH. Machines built after January 1993 will incorporate a three position switch to give the operator an additional drive speed.

Note

The Drive Motor Speed Switch will cut-out when platform is raised above stowed position, leaving only low speed available until platform is lowered completely.

CAUTION

DO NOT OPERATE MACHINE IF HIGH DRIVE SPEED OPERATES WHEN PLATFORM IS RAISED ABOVE THE STOWED POSITION.

(10). PQ Controller. (If Equipped.)

The PQ Controller performs three functions: Drive, Steer and Drive Speed. Tilting the controller in the direction you want to go (forward or reverse) activates drive in that direction. The thumb-operated steer switch on top of the controller handle activates the steer wheels in the direction it is moved. Drive speed is determined by distance the controller handle is moved forward or backward.

(11). Horn. (If Equipped.)

This push-button switch, when activated, permits the operator to warn jobsite personnel when the machine is operating in the area.

(12). Battery Condition Indicator/Hourmeter. (If Equipped.)

The battery condition indicator is a gauge that provides a visual indication of the condition of the batteries, and also includes an hourmeter to indicate the number of hours the machine has been operated.

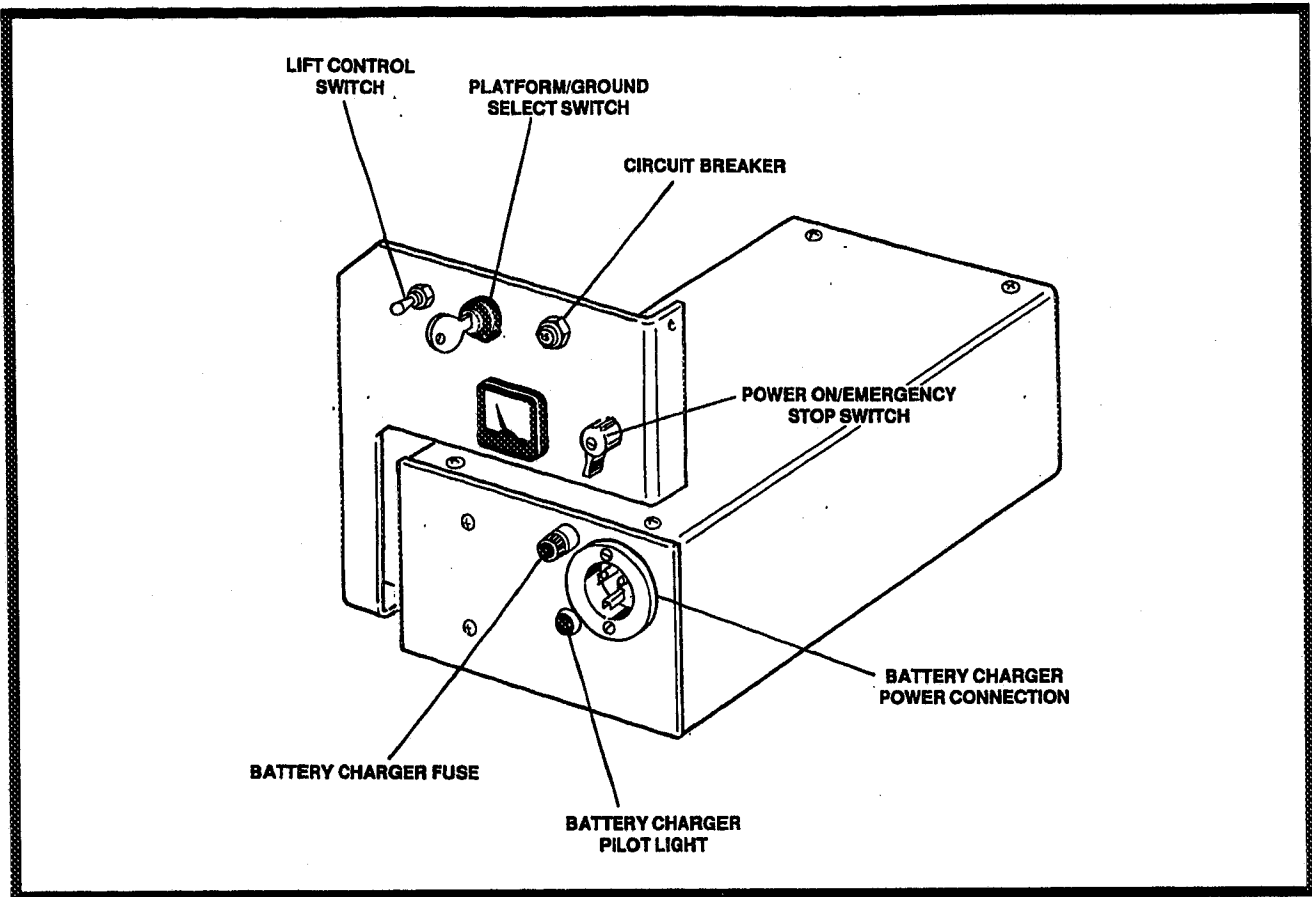

Figure 3-1. Ground Control Station - CM2033/CM2046/CM2546/CM2558.

(13). Powered Deck Extension Switch.
(If Equipped)

The machine may be equipped with either a 4 ft. (1.2 m) or 6 ft. (1.8 m) hydraulically powered deck extension. When equipped, a toggle switch mounted on the platform control console controls deck extension and retraction.

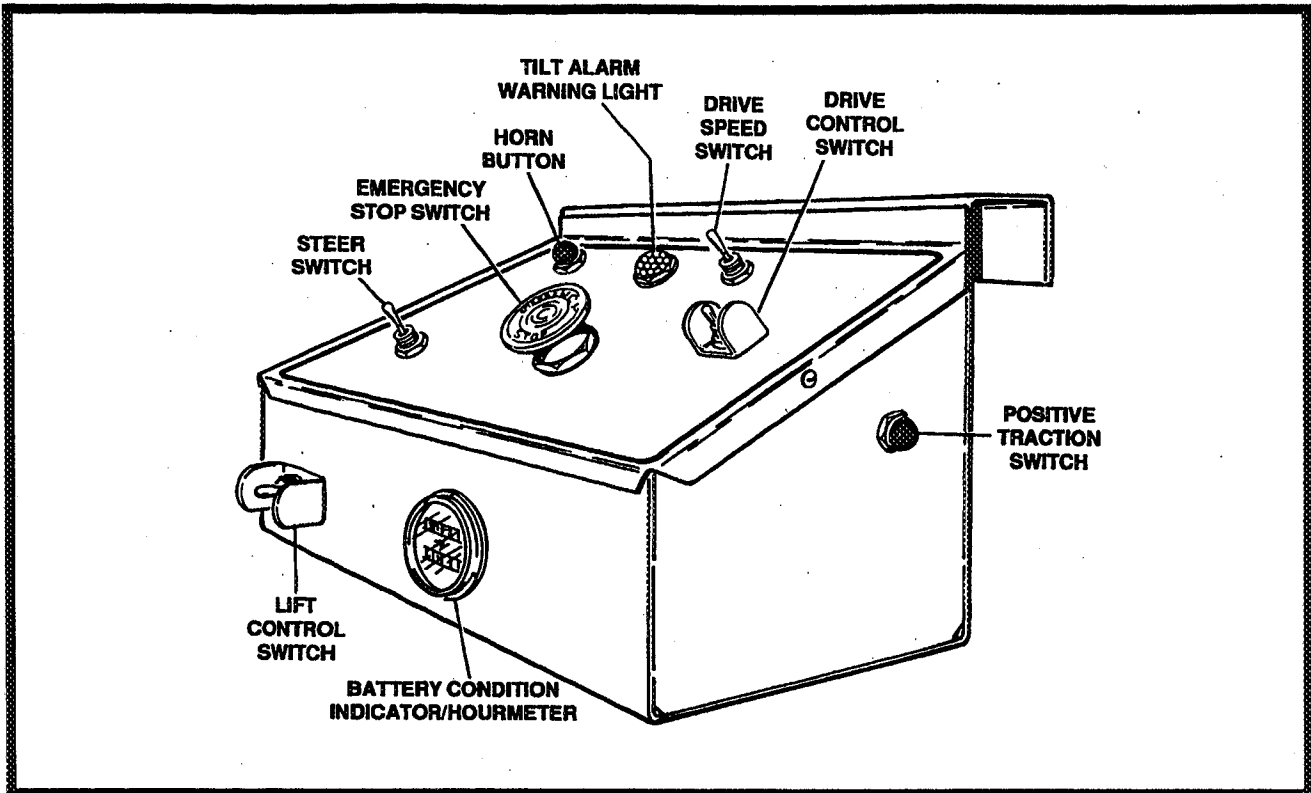

Figure 3-2. Platform Control Station w/o PQ Controller - CM2033/CM2046/CM2546/CM2558 - Machines Built Before August 1992.

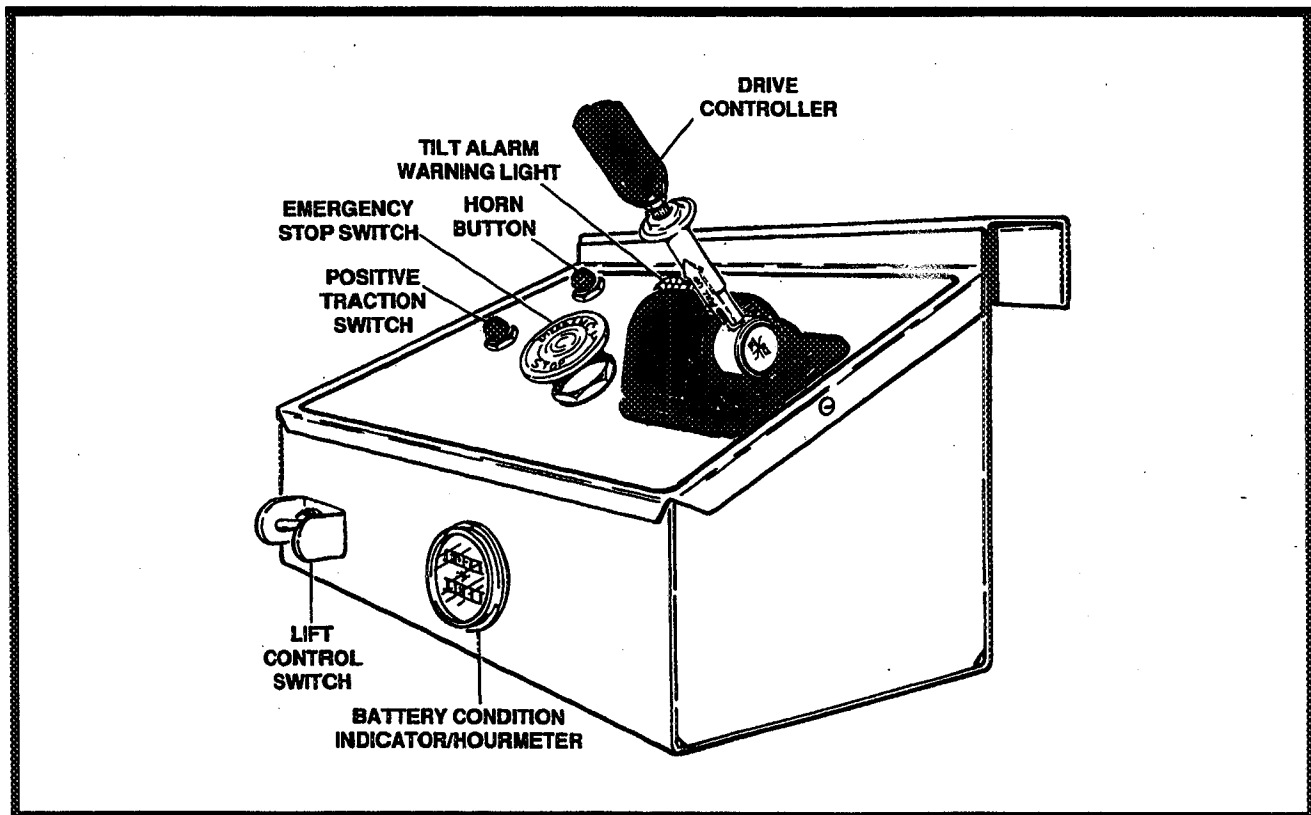

Figure 3-3. Platform Control Station w/PQ Controller - CM2033/CM2046/CM2546/CM2558 - Machines Built Before August 1992.

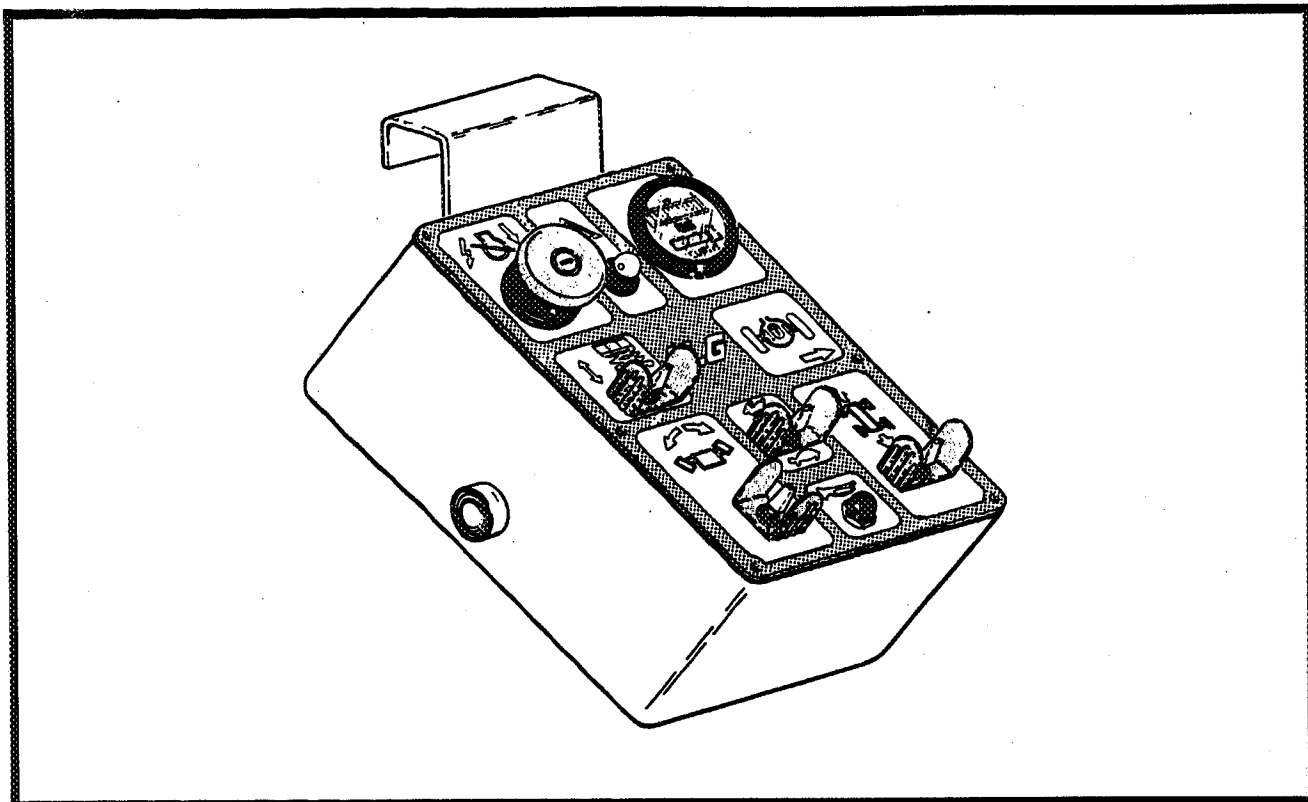

Figure 3-4. Platform Control Station w/o PQ Controller - CM2033/CM2046/CM2546/CM2558 - Machines Built After August 1992.

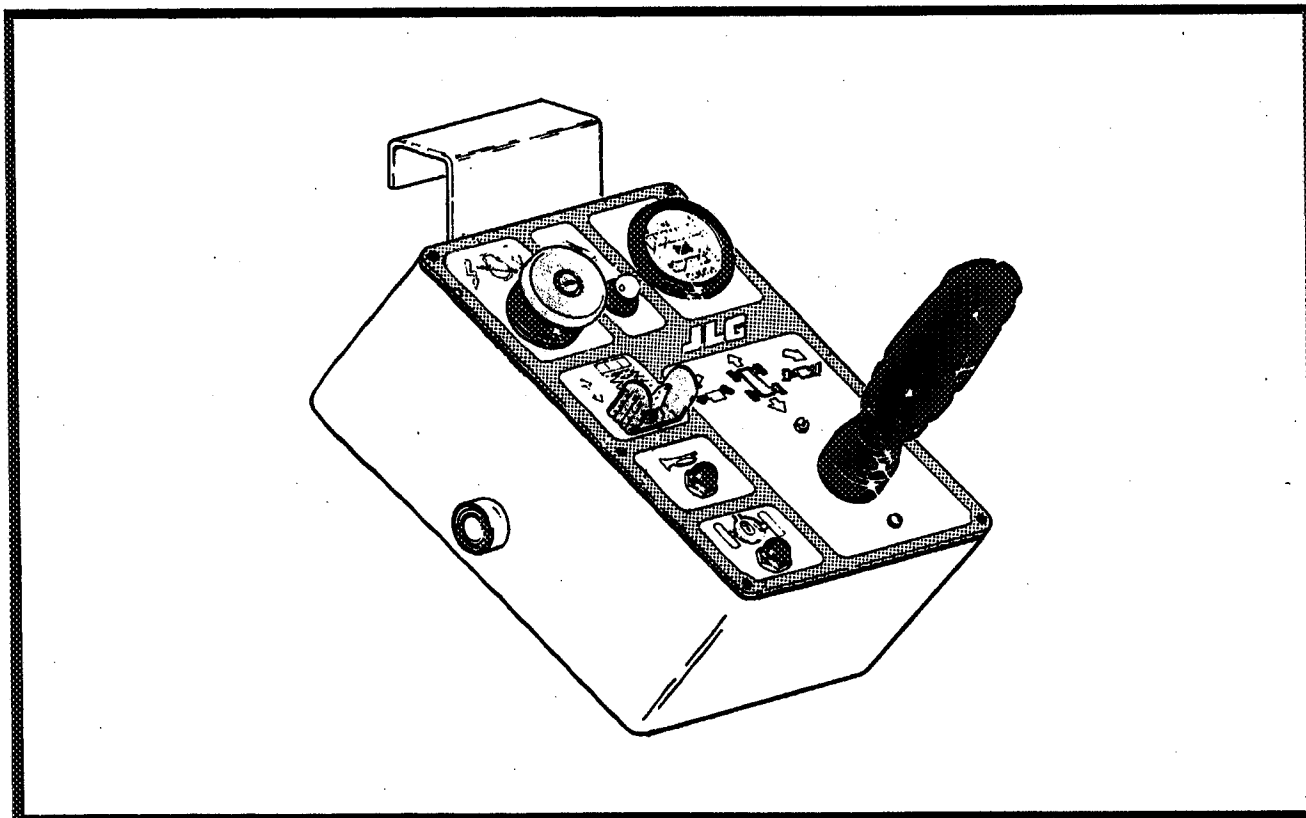

Figure 3-5. Platform Control Station w/PQ Controller - CM2033/CM2046/CM2546/CM2558 - Machines Built After August 1992.

Table 3-1. Control Panel Symbols. (Sheet 1 of 3)











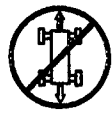
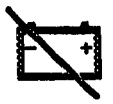



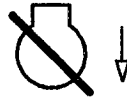



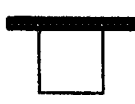

FUNCTION	SYMBOL	FUNCTION	SYMBOL
AUXILIARY POWER		DRIVE CUT-OUT	
BATTERY DISCONNECT		DUAL FUEL	
CAUTION		ELECTRICAL HAZARD	
CAUTION		EMERGENCY SHUT-OFF	
CHASSIS OUT OF LEVEL		EMERGENCY SWITCH DOWN	
CHOKE		EMERGENCY SWITCH UP	
CIRCUIT BREAKER		ENGINE SPEED	
COLD START		EXPLOSION HAZARD	
CREEP		EXTENDABLE PLATFORM CAPACITY	
CRUSHING		FACTORY MUTUAL APPROVED	
DANGER		FAN	
DRIVE		FAST	

Table 3-1. Control Panel Symbols. (Sheet 2 of 3)

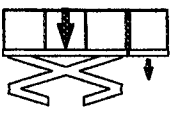



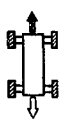





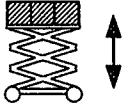





FUNCTION	SYMBOL	FUNCTION	SYMBOL
FIXED PLATFORM CAPACITY		LIFT	
FUEL		LIFT CUT-OUT	
HAND CRUSHING HAZARD		LIFTING AREA	
HIGH ENGINE SPEED		LP GAS	
HORN		MANUAL	
HYDRAULIC OIL		MANUAL DESCENT	
HYDRAULIC OIL LEVEL (LOW)		MANUAL DESCENT KNOB	
HYDRAULIC OIL LEVEL (HIGH)		MASTER SWITCH	
IGNITION		MASTER SWITCH OFF	
IMPORTANT (SAFETY INSTRUCTIONS)	IMPORTANT	MAXIMUM PERMISSIBLE PLATFORM SIDE LOAD	
INDOOR USE ONLY		MAXIMUM PLATFORM LOAD	

Table 3-1. Control Panel Symbols. (Sheet 3 of 3)

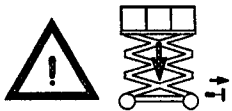
FUNCTION	SYMBOL	FUNCTION	SYMBOL
MAXIMUM WIND SPEED		SLOW	
NO LIFTING AREA		STEER	
NO TIE DOWN AREA		TIE DOWN AREA	
PLATFORM ELEVATED DRIVE ON SMOOTH LEVEL SURFACE		TILT	
PLATFORM/GROUND SELECT		TWO WHEEL DRIVE/FOUR WHEEL DRIVE	
PLATFORM TRAVERSE		TRAVERSING PLATFORM/CAPACITY	
POSITIVE TRACTION DISENGAGED		"UL" DOUBLE E RATED	
POSITIVE TRACTION ENGAGED		WARNING	
RESTRICTED DRIVE ON ROUGH TERRAIN		WHEEL SPEED	
RESTRICTED DRIVE ON SLOPE		WORK LIGHTS	

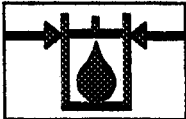
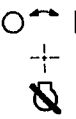
4-1. DESCRIPTION.

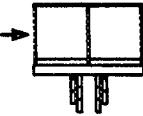
This machine is a self-propelled aerial work platform on top of an elevating 'sizzor' mechanism. The Sizzor Lift's intended purpose is to position personnel with their tools and supplies at positions above ground level. The machine can be used to reach work areas located above machinery or equipment positioned at ground level.

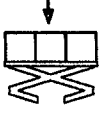
The JLG Sizzor Lift has a primary operator Control Station in the platform. From this Control Station, the operator can drive and steer the machine in both forward and reverse directions as well as raise and lower the platform. The machine has a Ground Control Station which will override the Platform Control Station. Ground Controls operate lift up and down and are to be used only in an emergency to lower the platform to the ground should the operator in the platform be unable to do so.

Instructions and hazard warnings are posted adjacent to both operator control stations and at other places on the machine. It is extremely important that operators know what instructions and warnings are placed on the machine, and review these periodically so that they are fresh in their minds.

The JLG Sizzor Lift is designed to provide efficient and safe operation when maintained and operated in accordance with warnings on the machine, the Operating and Safety Manual, the Service and Maintenance Manual and all jobsite and government rules and regulations. As with any type of machinery, the operator is very important to efficient and safe operation. It is absolutely necessary that the JLG Lift be regularly maintained in accordance with this manual and the machine Service and Maintenance Manual, and that any evidence of lack of maintenance, malfunction, excessive wear, damage or modification to the machine be reported immediately to the machine owner or the jobsite supervisor or safety manager and that the machine be taken out of service until all discrepancies are corrected.

The JLG Sizzor Lift is not intended to be used to lift material other than supplies which personnel in the platform require to do their job. Supplies or tools which extend outside the platform are prohibited. It must not be used as a forklift, crane, support for overhead structure, or to push or pull another object.

The JLG Sizzor Lift is powered using hydraulic motors and cylinders for the various machine motions. The hydraulic components are controlled by electrically activated hydraulic valves using switches and control levers. The speeds of functions controlled by control levers are variable from zero to maximum speed depending upon the position of the control lever. Functions controlled by

toggle switches are either on or off and higher or lower speed is possible only when the applicable high function speed control switch at the Platform Control Station is used in conjunction with the function toggle switch.

The JLG Sizzor is a two wheel drive machine with drive power being supplied by a hydraulic motor for each drive wheel. The rear wheels are supplied with hydraulically applied and released brakes. These brakes are automatically applied any time the Drive control is returned to the neutral position.

The capacity of model CM2033 is 750 lb. (340 kg) (see note below), the capacity of model CM2546 is 750 lb. (340 kg) and the capacity of models CM2046 and CM 2558 is 1,000 lb. (454 kg), uniformly distributed in the center of the platform. This means that the total combined weight of personnel, tools and supplies must not exceed the above figures.

Note

Some Model CM2033 machines may have a reduced platform capacity when equipped with non-marking tires. Refer to the platform capacity decal on the machine for proper platform capacity.

The platform may be raised only when positioned on firm, level and uniform surfaces.

4-2. GENERAL.

This section provides the necessary information needed to operate the machine. Included in this section are the procedures for starting, stopping, traveling, steering, parking, platform loading and transporting. It is important that the user read and understand the proper procedures before operating the machine.

4-3. MOTOR OPERATION.

a. Emergency Stop Switch.

This switch, when in the ON position, provides battery power to the Power Selector switch for all machine functions. The switch should be in the OFF position when recharging the batteries and/or parking the machine overnight.

b. Power Selector Switch.

The Power Selector switch functions to direct battery power to the desired control station. With the switch in the GROUND position, battery power is supplied to the ground control station. When the switch is in the PLATFORM position, battery power is supplied to the platform control station.

Note

Some machines built before August 1992 and all machines built after August 1992 are equipped with an ENABLE switch on the platform control box. This switch must be depressed before activating DRIVE, LIFT, or STEER functions from the platform control box.

c. Motor Activation.

With the Emergency Stop switch in the ON position, the Power Selector switch in the appropriate position, the Emergency Stop switch in the ON position (if operator is at platform controls) and a function switch is operated and held, the motor becomes activated and operates the desired function.

CAUTION

IF A MOTOR MALFUNCTION NECESSITATES UNSCHEDULED SHUTDOWN, DETERMINE AND CORRECT CAUSE BEFORE RESUMING ANY OPERATION.

IMPORTANT

ALWAYS POSITION EMERGENCY STOP SWITCH TO THE 'OFF' POSITION WHEN MACHINE IS NOT IN USE. FAILURE TO DO SO MAY CAUSE UNNECESSARY DRAINAGE OF POWER FROM BATTERIES.

4-4. RAISING AND LOWERING. (Lifting)**WARNING**

DO NOT RAISE PLATFORM EXCEPT ON A HARD, LEVEL SURFACE FREE OF OBSTRUCTIONS AND HOLES.

Note

Some machines built before August 1992 and all machines built after August 1992 are equipped with an **ENABLE** switch on the side of the platform control box. This switch must be depressed before activating **DRIVE**, **LIFT**, or **STEER** functions from the platform control box.

a. Raising.

- (1). If machine is shut down, turn Emergency Stop Switch to ON position.
- (2). Place Power Selector switch to appropriate position.
- (3). Position Lift switch to UP and hold until desired elevation is achieved. If equipped, depress Enable switch before activating LIFT UP function.

b. Lowering.**WARNING**

ENSURE SIZZOR ARM AREA IS FREE OF PERSONNEL PRIOR TO LOWERING PLATFORM.

Position Lift switch to DOWN and hold until desired elevation is achieved or until platform is fully lowered. If equipped, depress Enable switch before activating LIFT DOWN function.

WARNING

DO NOT 'LIFT DOWN' WITHOUT COMPLETELY RETRACTING OPTIONAL EXTENDING PLATFORM.

4-5. PLATFORM EXTENSION. (If Equipped.)

The machine may be equipped with a mechanically extendable deck, which adds 3 feet (0.9 meters) to the front of the platform, giving the operator better access to worksites. To extend the deck, squeeze the release lever on the handle on the left side of the platform to release the latch and use the handle to push the extendable deck out. When the deck reaches the end of its travel, the latch will lock to hold the deck in place. To retract the deck, squeeze the release lever to release the latch and use the handle to retract the deck. Be sure the latch locks the deck in place after it is retracted. Maximum capacity of the deck extension is 250 lbs. (113 kg).

As an additional option, the machine may be equipped with a hydraulically powered deck extension of either 4 feet (1.2 m) or 6 feet (1.8 m). The deck is operated by one of a pair of toggle switches, one located on the ground control panel and the other located on the platform control console. To operate the deck, push the toggle switch in the applicable direction for extension or retraction. Maximum capacity of the 4 foot (1.2 m) deck extension is 750 lb. (340 kg). Maximum capacity of the 6 foot (1.8 m) deck extension is 350 lb. (159 kg).

4-6. STEERING.**a. Toggle Switch Operated - w/o PQ Controller.**

To steer the machine, the STEER toggle switch is positioned to the right for traveling right, or to the left for traveling left. If machine is equipped with an Enable switch, depress Enable switch before activating STEER function.

When released, the switch will return to the center-off position and the wheels will remain in the previously selected position. To return the wheels to the straightened position, the switch must be activated in the opposite direction until the wheels are centered.

b. Thumb Operated - w/PQ Controller.

To steer the machine, the thumb operated steer control switch on the controller handle is positioned to the right for traveling right, or to the left for traveling left. If machine is equipped with an Enable switch, depress Enable switch before activating STEER function.

When released, the switch will return to the center-off position and the wheels will remain in the previously selected position. To return the wheels to the straightened position, the switch must be activated in the opposite direction until the wheels are centered.

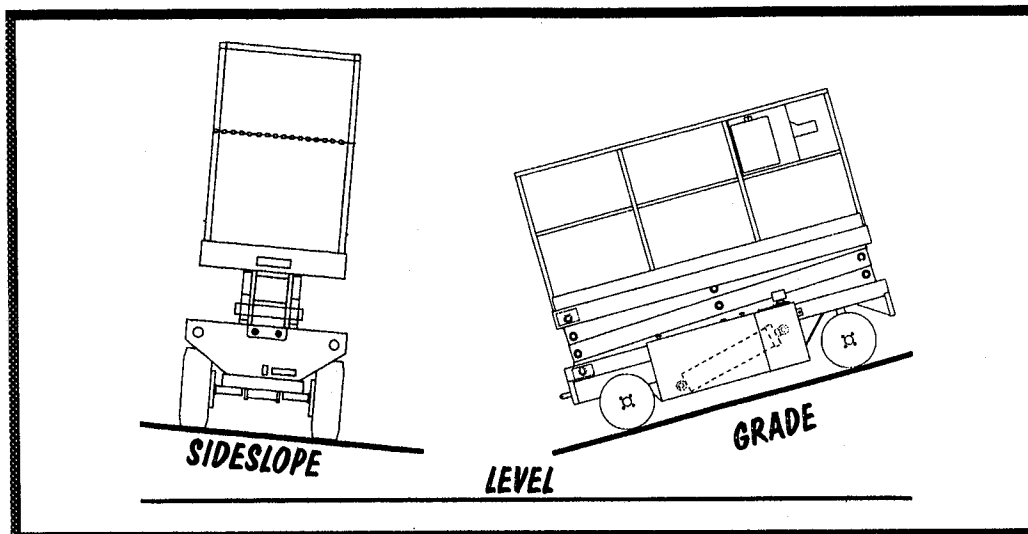

Figure 4-1. Grade and Sideslope.

4-7. TRAVELING. (Driving) (See Figure 4-1.)

WARNINGS

DO NOT DRIVE WITH PLATFORM RAISED EXCEPT ON A SMOOTH, FIRM AND LEVEL SURFACE FREE OF OBSTRUCTIONS AND HOLES.

TO AVOID LOSS OF TRAVEL CONTROL OR UPSET ON GRADES AND SIDESLOPES, DO NOT DRIVE MACHINE ON GRADES OR SIDESLOPES EXCEEDING THOSE SPECIFIED ON CAUTION PLACARD AT PLATFORM.

TRAVEL GRADES IN "LOW" DRIVE SPEED ONLY. USE EXTREME CAUTION WHEN DRIVING IN REVERSE AND AT ALL TIMES WHEN DRIVING WITH PLATFORM ELEVATED AND ESPECIALLY WHEN DRIVING WITH ANY PART OF MACHINE WITHIN 6 FEET (1.8 M) OF AN OBSTRUCTION.

Note

Some machines built before August 1992 and all machines built after August 1992 are equipped with an **ENABLE** switch on the side of the platform control box. This switch must be depressed before activating **DRIVE**, **LIFT**, or **STEER** functions from the platform control box.

b. Traveling Forward.

- (1). If machine is shut down, turn Emergency Stop switch at Ground Control Station to ON position.
- (2). Place Power Selector switch at ground control to PLATFORM.
- (3). If machine is not equipped with a PQ controller, position Drive Motor Speed switch to desired position and position Drive switch to FORWARD and hold for duration

of travel. If machine is equipped with Enable switch, Enable switch must be depressed before activating **DRIVE** function.

- (4). If machine is equipped with a PQ controller, position control handle to FORWARD and hold for duration of travel. Drive speed is determined by the distance the control handle is moved from the center off position. If machine is equipped with Enable switch, Enable switch must be depressed before activating **DRIVE** function.

b. Traveling in Reverse.

- (1). If machine is shut down, turn Emergency Stop switch at Ground Control Station to ON position.
- (2). Place Power Selector switch at ground control to PLATFORM.
- (3). If machine is not equipped with a PQ controller, position Drive Motor Speed switch to desired position and position Drive switch to REVERSE and hold for duration of travel. If machine is equipped with Enable switch, Enable switch must be depressed before activating **DRIVE** function.
- (4). If machine is equipped with a PQ controller, position control handle to REVERSE and hold for duration of travel. Drive speed is determined by the distance the control handle is moved from the center off position. If machine is equipped with Enable switch, Enable switch must be depressed before activating **DRIVE** function.

4-8. PARKING AND STOWING.**Note**

When parking battery-powered units overnight, batteries should be charged in accordance with instructions in Section 2 to ensure readiness for the following workday.

Park and stow machine as follows:

- a. Drive machine to a reasonably well-protected and well-ventilated area.
- b. Ensure platform is fully lowered.
- c. Position Emergency Stop switch to OFF position.
- d. If necessary, cover the instruction placards, caution and warning decals so that they will be protected from hostile environment.
- e. Chock at least two wheels when parking machine for an extended period of time.
- f. Turn Power Selector switch to OFF and remove key to disable machine from unauthorized use.

4-9. PLATFORM LOADING.

- a. The platform maximum rated load capacity is shown on a placard located on the platform and is based upon the following criteria.

- (1). Machine is positioned on a smooth, firm and level surface.
- (2). All braking devices are engaged.
- (3). Maximum capacity for each model is as follows:
CM2033 - 750 lb. (340 kg)

Note

Some Model CM2033 machines may have a reduced platform capacity when equipped with non-marking tires. Refer to the platform capacity decal on the machine for proper platform capacity.

- CM2046 - 1,000 lb. (454 kg)
- CM2546 - 750 lb. (340 kg)
- CM2558 - 1,000 lb. (454 kg)
- (4). Maximum capacity of platform extension is 250 lb. (113 kg).
- (5). Maximum capacity of the 4 foot (1.2 m) powered deck extension is 750 lb. (340 kg). Maximum capacity of the 6 foot (1.8 m) powered deck extension is 350 lb. (159 kg).

Note

Total machine capacity with the powered deck extension is 750 lb. (340 kg). On machines equipped with the 4 foot (1.2 m) extension, up to 750 lb. (340 kg) may be placed on the extension. On machines equipped with the 6 foot (1.8 m) extension, up to 350 lb. (159 kg) may be placed on the extension. In either case, total machine capacity must not exceed 750 lb. (340 kg).

- b. It is important to remember that the load should be evenly distributed on the platform. The load should be placed near the center of the platform when possible.

4-10. SAFETY PROP.**CAUTION**

SAFETY PROP MUST BE USED WHEN MAINTENANCE PERFORMED ON MACHINE REQUIRES SIZZOR ARMS TO BE RAISED.

- a. To engage safety prop, raise platform, then rotate prop clockwise until it hangs vertically. Lower the platform until the safety prop rests on the point provided on the frame. Maintenance can now begin.
- b. To store safety prop, raise platform so that prop can be rotated counterclockwise until it rests on the stop provided on the sizzor arms.

4-11. TIE DOWN AND LIFTING.**a. Tie Down.**

When transporting machine, platform must be fully retracted in the stowed mode with machine securely tied down to truck or trailer deck. On model CM2033, three tie down eyes, one at the front of the frame and two at the rear of the frame are provided. On models CM2046, CM2546 and CM2558, four tie down eyes are provided in the frame, two at the front of the frame and two at the rear of the frame.

WARNING

USE TIE DOWN EYES ONLY TO SECURE THE MACHINE FOR SHIPPING. DO NOT USE TIE DOWN EYES TO LIFT MACHINE.

b. Lifting.

If it becomes necessary to lift the machine, a pair of forklift tubes are provided at the rear of the machine. It is very important that the forklift operator use only the designated lifting tubes to lift the machine.

Note

Forklifts must be capable of handling the following weights: CM2033 - 3,300 lb. (1,497 kg), CM2046 - 3,600 lb. (1,633 kg), CM2546 - 4,300 lb. (1,950 kg), CM2558 - 4,500 lb. (2,087 kg).

4-12. TOWING.

It is not recommended that this machine be towed, except in the event of an emergency such as a machine malfunction or a total machine power failure. Refer to Section 6 for emergency towing procedures.

5-1. PQ CONTROLLER.

A "multiple-step" controller is available which operates STEER and DRIVE from a single control handle.

5-2. HORN.

The warning horn is located on the frame of the machine, and is controlled by a push button switch on the platform control console. The warning horn permits the operator to warn jobsite personnel when the machine is operating in the area.

5-3. TRAVEL ALARM.

The travel alarm horn, mounted on the frame of the machine, provides an audible warning when the machine is in the travel (DRIVE) mode. It will function in FORWARD or REVERSE to warn jobsite personnel the machine is traveling.

5-4. MOTION ALARM.

The motion alarm horn, mounted on the frame of the machine, provides an audible warning when the machine is in the travel (DRIVE) or LIFT mode. It will function in FORWARD, REVERSE, LIFT UP or LIFT DOWN to warn jobsite personnel the machine is traveling or lifting.

5-5. DESCENT ALARM.

Produces an audible warning when platform LIFT control is placed in the LIFT DOWN position. The alarm warns personnel in the jobsite area to avoid the sizzor arms.

5-6. TILT ALARM.

Senses when the machine is out of level in any direction approximately 5° and illuminates a warning light at the platform control station and sounds the machine's horn, signaling the operator.

5-7. 110 VOLT GENERATOR.

A 110 Volt generator, mounted on the machine frame, functions to supply 110 Volt electrical power to the platform to run assorted power tools which use normal AC current. It is powered by the machine's batteries.

5-8. 110 VOLT RECEPTACLE.

The 110 Volt dual receptacle is mounted on the platform kick rail. The receptacle is connected to a plug on the machine frame which can be connected to either a ground receptacle or the optional 110 Volt generator.

5-9. PLATFORM WORK LIGHTS.

The two platform work lights are installed on the platform rails to provide additional lighting for the operator. Each light is equipped with an on-off switch.

**5-10. FOAM-FILLED TIRES.
(CM2046 and CM2558 Only.)**

These tires provide stability and eliminate flats by filling the tubes with polyurethane foam. For use where sharp objects are frequently encountered on the jobsite.

5-11. NON-MARKING TIRES.

For indoor use, these tires are made from a special compound that, unlike regular tires, will not leave black skid marks on floors and other surfaces.

Note

Some Model CM2033 machines may have a reduced platform capacity when equipped with non-marking tires. Refer to the platform capacity decal on the machine for proper platform capacity.

5-12. ROTATING BEACON.

An amber rotating beacon is installed on the machine platform rail. When the machine power is turned on, the light is activated and provides a visual warning to the machine's operation.

**5-13. HIGH OUTPUT BATTERIES.
(CM2046, CM2546 and CM2558 Only.)**

For increased operating power and reserve capacity, 370 Amp Hour batteries are available in place of the standard 245 Amp Hour batteries.

5-14. BATTERY CONDITION INDICATOR.

The battery condition indicator is a gauge that provides a visual indication of the condition of the batteries, and also includes an hourmeter to indicate the number of hours the machine has been operated.

5-15. FOLD-DOWN HAND RAILS.

The fold-down handrails enable the operator to take the machine into areas where platform height may pose a clearance problem. The fold-down hand rails give the operator an additional 10.5 inches (27 cm) clearance.

5-16. CONTROL BOX COVER.

A hinged metal cover on the platform control box, which can be pinned in place to cover the platform controls when the machine is not in use. When the pin is removed, the cover can be flipped out of the way for machine operation.

5-17. LIFTING LUGS.

The machine may be equipped with lifting lugs, welded to the four corners of the machine frame. These lugs enable the machine to be lifted using chains or other suitable lifting devices.

5-18. POWERED DECK EXTENSION.

The machine may be equipped with a hydraulically powered deck extension, either 4 ft. (1.2 m) or 6 ft. (1.8 m) in length. When equipped, a toggle switch is located at both the ground control panel and the platform control console to operate the deck extension.

6-1. GENERAL.

This section provides information on the procedures to be followed and on the systems and controls to be used in the event an emergency situation is encountered during machine operation. Prior to operation of the machine and periodically thereafter, the entire operating manual, including this section, should be reviewed by all personnel whose responsibilities include any work or contact with the machine.

6-2. EMERGENCY TOWING PROCEDURES.

a. Although towing the machine is prohibited, provisions for moving the machine, in case of a malfunction or power failure, have been incorporated. The following procedures are to be used **ONLY** for emergency movement to a suitable maintenance area.

- (1). Chock wheels securely.
- (2). Turn free-wheeling valve knob on main control valve counterclockwise all the way out.
- (3). If machine is equipped with handle type parking brake (machines built prior to March 1992), pull parking brake handle to release parking brake and attach handle to hook on machine frame.
- (4). If machine is equipped with hydraulically operated parking brake (machines built after March 1992), release parking brake as follows:
 - (a). Using a suitable sized wrench, move brake cam to horizontal position.
 - (b). Repeat step (a) for remaining brake cylinder.
- (5). Using suitable equipment for assistance, remove chocks, and move machine to an appropriate maintenance area.

b. After moving machine, complete the following procedures:

- (1). Position machine on a firm, level surface.
- (2). Chock wheels securely.
- (3). If machine is equipped with handle type parking brake (machines built prior to March 1992), engage parking brake by removing parking brake handle from hook on machine frame.

(4). If machine is equipped with hydraulically operated parking brake (machines built after March 1992), engage parking brake as follows:

- (a). Using a suitable sized wrench, move brake cam to vertical position.
- (b). Repeat step (a) for remaining brake cylinder.

(5). Turn free-wheeling valve knob on main control valve clockwise all the way in.

(6). Remove chocks from wheels.

6-3. EMERGENCY CONTROLS AND THEIR LOCATIONS.**a. Emergency Stop Switch.**

This large red button is located on the platform control box and, when depressed, it will immediately stop the machine.

WARNING

CHECK MACHINE DAILY TO MAKE SURE EMERGENCY STOP BUTTON IS IN PLACE AND THAT GROUND CONTROL INSTRUCTIONS ARE IN PLACE AND LEGIBLE.

b. Ground Control Station.

The Ground Control Station is located on the right side of the machine frame. The controls on this panel provide the means for overriding the platform controls and for controlling the platform lift up and down functions from the ground. Place the station **SELECT SWITCH** in the **GROUND** position and operate the lift switch to lift up or down.

c. Manual Descent.

The manual descent/lift down solenoid is used, in the event of total power failure, to lower the platform using gravity. The manual descent knob is located on the machine frame, between the sizzor arms. The knob is connected, by cable, to the manual descent/lift down solenoid on the lift cylinder. Pulling the manual descent knob opens the solenoid, lowering the platform.

6-4. EMERGENCY OPERATION.**a. Use of Ground Controls.****KNOW HOW TO USE THE GROUND CONTROLS IN AN EMERGENCY SITUATION.**

Ground personnel must be thoroughly familiar with the machine operating characteristics and the ground control functions. Training should include operation of the machine, review and understanding of this section and hands-on operation of the controls in simulated emergencies.

b. Operator Unable to Control Machine.**IF THE PLATFORM OPERATOR IS PINNED, TRAPPED OR UNABLE TO OPERATE OR CONTROL THE MACHINE.**

- (1). Operate the machine from ground controls **ONLY** with the assistance of other personnel and equipment (cranes, overhead hoists, etc.) as may be required to safely remove the danger or emergency condition.
- (2). Other qualified personnel on the platform may use the platform controls with regular or auxiliary power. **DO NOT CONTINUE OPERATION IF CONTROLS DO NOT FUNCTION NORMALLY.**
- (3). Cranes, forklift trucks or other equipment which may be available are to be used to remove platform occupants and stabilize motion of the machine in case machine controls are inadequate or malfunction when used.

c. Platform Caught Overhead.

If the platform becomes jammed or snagged in overhead structures or equipment, do not continue operation of the machine from either the platform or the ground until the operator and all personnel are safely moved to a secure location. Only then should an attempt be made to free the platform using any necessary equipment and personnel. **Do not operate controls to cause one or more wheels to leave the ground.**

d. Righting of Tipped Machine.

A forklift of suitable capacity or equivalent equipment should be placed under the elevated side of the chassis, with a crane or other suitable lifting equipment used to lift the platform while the chassis is lowered by the forklift or other equipment.

e. Post-Incident Inspection.

Following any accident, thoroughly inspect the machine and test all functions first from the ground controls, then from the platform controls. Do not lift above 10 feet (3 meters) until you are secure that all damage has been repaired, if required, and that all controls are operating correctly.

6-5. INCIDENT NOTIFICATIONS.

- a. It is imperative that JLG Industries, Inc. be notified immediately of any incident involving a JLG product. Even if no injury or property damage is evident, the Product Safety and Reliability Department at the factory should be contacted by telephone and provided with all necessary details.
- b. It should be noted that failure to notify the Manufacturer of an incident involving a JLG Industries product within 48 hours of such an occurrence may void any warranty consideration on that particular machine.

7-1. CAPACITIES.

- **Hydraulic Oil Tank.**
 - CM2033/CM2046 - 7.7 U.S. gal. (29.2 ltr.).
 - CM2546/CM2558 - 7.7 U.S. gal. (29.2 ltr.).
- **Hydraulic System. (Including Tank)**
 - CM2033/CM2046 - 9.2 U.S. gal. (34.8 ltr.).
 - CM2546/CM2558 - 9.2 U.S. gal. (34.8 ltr.).

7-2. COMPONENT DATA.

- **Hydraulic Pump/Electric Motor Assembly.**
(All Models)
 - 24 Volt DC motor.
 - 2 section gear pump - 3.13 gpm (11.84 lpm) output each section.
- **Battery Charger.**
 - 24 Volts DC - 25 Amp output w/auto timer.
- **Batteries (4).**
 - Standard - All Models - 6 Volt, 245 Amp hour (20 hour rate).
 - High Output - CM2046/CM2546/CM2558 Only - 6 Volt, 370 Amp hour (20 hour rate).
- **Steer/Drive System.**
 - Tires.
 - Standard - All Models - 5 x 8 - 3.75 Solid - Rib.
 - Optional - All Models - 5 x 8 - 3.75 Solid, Non-Marking.
 - Parking Brake - All models.
 - Machines built before March 1992 - spring applied, mechanically released.
 - Machines built after March 1992 - dual cylinder, hydraulically applied and released.
 - Drive Motor.
 - CM2033/CM2046 - 11.9 in.³ (195 cm³) displacement.
 - CM2546/CM2558 - 14.9 in.³ (244 cm³) displacement.
- **Rear Wheels and Tires.**
 - Tires.
 - Standard - All models - 5 x 8 - 3.75 Solid - Rib.
 - Optional - All Models - 5 x 8 - 3.75 Solid, Non-Marking.
- **Hydraulic Filter - Inline.**
 - Return - Bypass Type.
 - 25 Microns Nominal.

7-3. PERFORMANCE DATA.

- **Travel Speed.**
 - CM2033/CM2046 - 2.75 mph (4.4 kmh).
 - CM2546/CM2558 - 2.25 mph (3.6 kmh).

- **Gradeability.**
 - CM2033/CM2046 - 25%.
 - CM2546/CM2558 - 25%.
- **Turning Radius (Outside).**
 - CM2033 - 87 in. (2.2 m).
 - CM2046 - 102.6 in. (2.6 m).
 - CM2546 - 102.6 in. (2.6 m).
 - CM2558 - 105 in. (2.7 m).
- **Lift.**
 - CM2033/CM2046.
 - Up - 25-30 seconds.
 - Down - 25-30 seconds.
 - CM2546/CM2558.
 - Up - 30-35 seconds.
 - Down - 30-35 seconds.
- **Platform Capacity.**
 - CM2033 - 750 lb. (340 kg)

Note

Some Model CM2033 machines may have a reduced platform capacity when equipped with non-marking tires. Refer to the platform capacity decal on the machine for proper platform capacity.

- CM2546 - 750 lb. (340 kg).
- CM2046/CM2558 - 1,000 lb. (454 kg).

- **Platform Extension Capacity.**
 - CM2033/CM2046 - 250 lb. (113 kg).
 - CM2546/CM2558 - 250 lb. (113 kg).
- **Powered Platform Extension Capacity.**
 - 4 Foot (1.2 m) Extension - 750 lb. (340 kg).
 - 6 Foot (1.8 m) Extension - 350 lb. (159 kg).

Note

On machines equipped with the powered deck extension, total machine capacity is 750 lb. (340 kg). On machines equipped with the 4 foot (1.2 m) extension, up to 750 lb. (340 kg) may be placed on the extension. On machines equipped with the 6 foot (1.8 m) extension, up to 350 lb. (159 kg) may be placed on the extension. In either case, total machine capacity must not exceed 750 lb. (340 kg).

- **Machine Weight.**
 - CM2033 - approx. 3,210 lb. (1,456 kg).
 - CM2046 - approx. 3,780 lb. (1,715 kg).
 - CM2546 - approx. 4,360 lb. (1,978 kg).
 - CM2558 - approx. 4,630 lb. (2,100 kg).
- **Machine Height (Platform Lowered).**
 - CM2033 - 39.12 in. (1.0 m).
 - CM2046 - 40.12 in. (1.0 m).
 - CM2546 - 45.5 in. (1.2 m).
 - CM2558 - 45.5 in. (1.2 m).

- **Machine Length.**
 - CM2033 - 101.5 in. (2.6 m).
 - CM2046 - 101.5 in. (2.6 m).
 - CM2546 - 101.5 in. (2.6 m).
 - CM2558 - 101.5 in. (2.6 m).

▪ **Machine Width.**

- CM2033 w/Standard Tires - 33 in. (0.8 m).
- CM2046 w/Standard Tires - 46 in. (1.2 m).
- CM2046 w/Optional Tires - 49.5 in. (1.3 m).
- CM2546 w/Standard Tires - 46 in. (1.2 m).
- CM2558 w/Standard Tires - 58 in. (1.5 m).
- CM2558 w/Optional Tires - 61.5 in. (1.6 m).

7-4. TORQUE REQUIREMENTS.

Description	Torque Value (Dry)	Interval Hours
A. Wheel Lugs	90 ft lb (12.4 kgm)	50
B. Drive Hub To Drive Motor	125-150 ft lb (17-21 kgm)	200/500*

Note

When maintenance becomes necessary or a fastener has loosened, refer to the Torque Chart Figure 7-1 to determine proper torque value.

7-5. LUBRICATION.

▪ **Hydraulic Oil.**

Table 7-1. Hydraulic Oil.

HYDRAULIC SYSTEM OPERATING TEMPERATURE RANGE	SAE VISCOSITY GRADE
0° F to +23° F (-18° C to -5° C)	10W
0° F to +210° F (-18° C to +99° C)	10W-20, 10W-30
50° F to 210° F (+10° C to +210° C)	20W-20

Notes

Hydraulic oils must have anti-wear qualities at least to API Service Classification GL-3, and sufficient chemical stability for mobile hydraulic system service. JLG Industries recommends Kendall Hyken 052 hydraulic oil, which has an SAE viscosity of 10W-20 and a viscosity index of 152 or, as an alternate, Mobilfluid 424 hydraulic oil, which has an SAE viscosity of 10W-30 and a viscosity index of 152. Kendall Hyken 052 and Mobilfluid 424 are fully compatible, and can be mixed as necessary.

When temperatures remain consistently below -20° F (-7° C), an amount of no. 2 diesel fuel, not to exceed 20% of system capacity, may be added to the hydraulic oil reservoir. This diesel fuel will "thin" the hydraulic oil for easier cold weather operation, and will almost completely dissipate from the hydraulic system over a several month period of time. When cold weather is past, it may be necessary to drain and refill the hydraulic system to rid the system of any remaining diesel fuel.

Aside from JLG recommendations, it is not advisable to mix oils of different brands or types, as they may not contain the same required additives or be of comparable viscosities. If use of hydraulic oil other than Kendall Hyken 052 or Mobilfluid 424 is desired, contact JLG Industries for proper recommendations.

▪ **Lubrication Specifications.**

Table 7-2. Lubrication Specifications.

KEY	SPECIFICATIONS
MPG	Multipurpose Grease having a minimum dripping point of 350° F. Excellent water resistance and adhesive qualities, and being of extreme pressure type. (Timken OK 40 pounds minimum.)
EPGL	Extreme Pressure Gear Lube (oil) meeting API service classification GL-5 or MIL-Spec MIL-L-2105.
HO	Hydraulic Oil. API service classification GL-3, e.g. Kendall Hyken 052 or Mobilfluid 424.

Note

Refer to Figure 7-2 for specific lubrication procedures.

7-6. CYLINDER SPECIFICATIONS.

Note

All dimensions are given in inches (in), with the metric equivalent, centimeters (cm), given in parentheses.

DESCRIPTION	BORE	STROKE	ROD DIA.
Lift Cylinder (CM2033/CM2046)	3.00 (5.1)	49.38 (125.4)	2.00 (5.1)
Lift Cylinder (CM2546/CM2558)	3.50 (8.9)	47.25 (120.0)	2.50 (6.4)
Steer Cylinder - Double Rod - All Models	2.00 (5.1)	2.75 (7.0)	1.25 (3.8)
		each rod	
Cushion Cylinder (Accumulator) - All Models - Machine Built Before March 1992	1.50 (3.8)	6.13 (15.6)	n/a
Cushion Cylinder (Accumulator) - All Models - Machines Built After March 1992	2.00 (5.1)	6.13 (15.6)	n/a
Parking Brake Cylinder - Machines Built Before March 1992	3.00 (7.6)	1.25 (3.8)	1.25 (3.8)
Parking Brake Cylinder - Machines Built After March 1992	1.75 (4.4)	0.88 (2.2)	1.13 (2.9)
Platform Extension Cylinder - 4 Ft. (1.2 m) (If Equipped)	1.50 (3.8)	48.00 (121.9)	1.00 (2.5)
Platform Extension Cylinder - 6 Ft. (1.8 m) (If Equipped)	1.50 (3.8)	72.00 (182.9)	1.00 (2.5)

SIZE	THD	BOLT DIA. (IN.)	TENSILE STRESS AREA (SQ.IN.)	SAE GRADE 5 BOLTS				SAE GRADE 8 BOLTS				RECOMMENDED TORQUE WRENCH SIZE		
				CLAMP LOAD (LB.)	TIGHTENING (DRY) LB. IN.	TORQUE (LUB.) LB. IN.	TORQUE (LOCTITE) LB. IN.	CLAMP LOAD (LB.)	TIGHTENING (DRY) LB. IN.	TORQUE (LUB.) LB. IN.	TORQUE (LOCTITE) LB. IN.	IN- OZS.	IN- LBS.	FT- LBS.
4	40	0.1120	0.00604	380	8	6		540	12	9		160	10	
	48	0.1120	0.00661	420	9	7		600	13	10		160	10	
6	32	0.1380	0.00909	580	16	12		820	23	17			25	
	40	0.1380	0.01015	610	18	13		920	25	19			25	
8	32	0.1640	0.01400	900	30	22		1260	41	31			25	
	36	0.1640	0.01474	940	31	23		1320	43	32			25	
10	24	0.1900	0.01750	1120	43	32		1580	60	45			50	
	32	0.1900	0.02000	1285	49	36		1800	68	51			50	
1/4	20	0.2500	0.0318	2020	96	75	105	2860	144	108	160		100	
	28	0.2500	0.0364	2320	120	86	135	3280	168	120	185		200	
					LB. FT.	LB. FT.	LB. FT.		LB. FT.	LB. FT.	LB. FT.			
5/16	18	0.3125	0.0524	3340	17	13	19	4720	25	18	30		200	
	24	0.3125	0.0580	3700	19	14	21	5220	25	20	30		200	
3/8	16	0.3750	0.0775	4940	30	23	35	7000	45	35	50		300	25
	24	0.3750	0.0878	5600	35	25	40	7900	50	35	55		300	50
7/16	14	0.4375	0.1063	6800	50	35	55	9550	70	55	80		600	50
	20	0.4375	0.1187	7550	55	40	60	10700	80	60	90		600	50
1/2	13	0.5000	0.1419	9050	75	55	85	12750	110	80	120		1200	100
	20	0.5000	0.1599	10700	90	65	100	14400	120	90	135		1200	100
9/16	12	0.5625	0.1820	11600	110	80	120	16400	150	110	165		1200	100
	18	0.5625	0.2030	12950	120	90	135	18250	170	130	190		1200	100
5/8	11	0.6250	0.2260	14400	150	110	165	20350	220	170	240		1800	150
	18	0.6250	0.2560	16300	170	130	190	23000	240	180	265		1800	150
3/4	10	0.7500	0.3340	21300	260	200	285	30100	380	280	420		2400	200
	16	0.7500	0.3730	23800	300	220	330	33600	420	320	465		2400	200
7/8	9	0.8750	0.4620	29400	430	320	475	41600	600	460	660		3600	300
	14	0.8750	0.5090	32400	470	350	520	45800	660	500	725		3600	300
1	8	1.0000	0.6060	38600	640	480	675	51500	900	680	990		7200	600
	12	1.0000	0.6630	42200	700	530	735	59700	1000	740	1100		7200	600
1 1/8	7	1.1250	0.7630	42300	800	600	840	68700	1280	960	1400		7200	600
	12	1.1250	0.8560	47500	880	660	925	77000	1440	1080	1575		7200	600
1 1/4	7	1.2500	0.9690	53800	1120	840	1175	87200	1820	1360	2000		Mult*	
	12	1.2500	1.0730	59600	1240	920	1300	96600	2000	1500	2200		Mult*	
1 3/8	6	1.3750	1.1550	64100	1460	1100	1525	104000	2380	1780	2625			
	12	1.3750	1.3150	73000	1680	1260	1750	118100	2720	2040	3000			
1 1/2	6	1.5000	1.4050	78000	1940	1460	2025	126500	3160	2360	3475			Mult*
	12	1.5000	1.5800	87700	2200	1640	2300	142200	3560	2660	3925			Mult*

Figure 7-1. Torque Chart.

NOTE: Tensile strength for bolt size 4 to 1 - 120,000 (min. psi), size 1-1/8 to 1-1/2 - 105,000 (min. psi).

*Torque multiplier.

Torque specifications are usually given in foot-pounds; lower ranges in inch-pounds or inch-ounces.



SAE Grade 5



SAE Grade 8

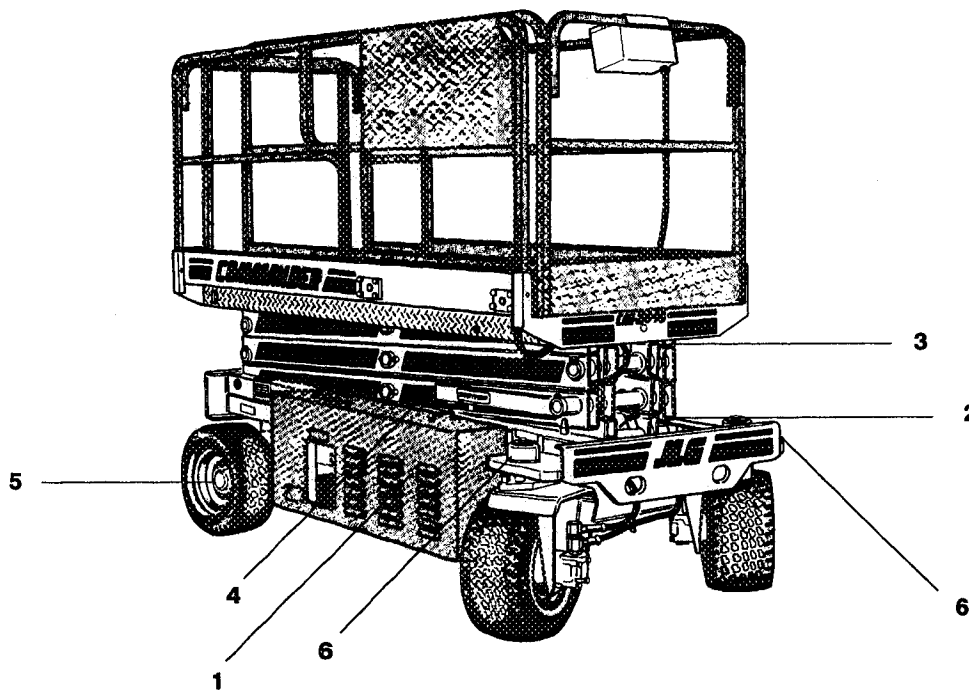

INDEX NUMBER	COMPONENT	NO/TYPE LUBE POINTS	LUBE/METHOD	INTERVAL HOURS	COMMENTS
1	Hydraulic Oil	Fill Cap/Drain Plug	HO - Check HO Level (See Note 4) HO - Change HO	10/2000	Check oil every 10 hrs. Change oil every 2000 hrs.
2	Hydraulic Filter Element	N/A	N/A	40/250	Change filter after first 40 hours of operation, then every 250 hours thereafter.
3	Lift Cylinder - Rod End	1 Grease Fitting	MPG - Pressure Gun	250	N/A
4	Lift Cylinder - Barrel End	1 Grease Fitting	MPG - Pressure Gun	250	N/A
5	Wheel Bearings	2 - Rear Wheels	MPG - Repack	2000	N/A
6	Kingpin Housing (If Equipped - See Note 5)	2 Grease Fittings	MPG - Pressure Gun	250	N/A

Key To Lubricants:

MPG - Multi-Purpose Grease

HO - Hydraulic Oil - Kendall Hyken 052 or Mobilfluid 424

WARNING

TO AVOID PERSONAL INJURY, USE SAFETY PROP FOR ALL MAINTENANCE REQUIRING PLATFORM TO BE ELEVATED.

Notes:

1. Be sure to lubricate like items on each side of machine.
2. Recommended lubricating intervals are based on normal use. If machine is subjected to severe operating conditions, user must adjust lubricating requirements accordingly.
3. Lubricating intervals are calculated on 50 hours of machine operation per week.
4. Prior to checking hydraulic oil level, operate machine through one complete cycle of lift function (full up and down). Failure to do so will result in incorrect oil level reading on hydraulic tank.
5. Machines built before March 1992 will be equipped with grease fittings at item 6; machines built after March 1992 will not be equipped with grease fittings.

Figure 7-2. Lubrication Chart - CM2033/CM2046/CM2546/CM2558.

7-7. PRESSURE SETTINGS.

Note

All pressures are given in pounds per square inch (PSI), with the metric equivalent, bar, given in parentheses.

On machines built before June 1993, Lift is controlled by P2. On machines built after June 1993, a separate Lift relief is provided.

- **All Models - Standard Machine.**
 - Main Relief - P1 - 2700 (186).
 - Main Relief - P2 - 2700 (186).
 - Steer Relief - 1500 (103).
 - Hi-Drive Sequence - 1100 (76).
 - Lift Relief. (If Equipped.)
 - CM2033 - 1800 (124).
 - CM2046 - 2150 (148).
 - CM2546 - 2050 (141).
 - CM2558 - 2300 (159).
- **All Models - Machine with Proportional Drive.**
 - Main Relief - P1 - 2700 (186).
 - Main Relief - P2 - 2700 (186).
 - Steer Relief - 1500 (103).
 - Hi-Drive Sequence - 1100 (76).
 - Lift Relief. (If Equipped.)
 - CM2033 - 1800 (124).
 - CM2046 - 2150 (148).
 - CM2546 - 2050 (141).
 - CM2558 - 2300 (159).

7-8. SERIAL NUMBER LOCATIONS.
(See Figure 7-3.)

For machine identification, a serial number plate is affixed to the machine. On models CM2033, CM2046, CM2546 and CM2558, the plate is located on the rear bumper of the machine frame. In addition, if the serial number plate is damaged or missing, the machine serial number is stamped on the right front of the frame, near the steering spindle and bushing.

7-9. LIMIT SWITCHES.

The machines are equipped with the following limit switches:

- Tilt Alarm (optional) - 5 degrees - Illuminates light on platform and sounds alarm when machine is 5 degrees out of level in any direction.
- High Drive Cut-Out - High drive speed is cut out when platform is raised above stowed position.
- Drive Cut-Out - On Model CM2033, if machine is equipped with non-marking tires or has a rated 1000 lb. (454 kg) platform capacity, drive function is cut out when platform is raised above 17 feet (5.2 meters).

Note

Some Model CM2033 machines may have a reduced platform capacity when equipped with non-marking tires. Refer to the platform capacity decal on the machine for proper platform capacity.

- Drive Cut-Out - On Model CM2546 equipped with foam filled tires, drive function is cut out when platform is raised above 21 feet (6.4 meters).

7-10. MAJOR COMPONENT WEIGHTS.

COMPONENT	LB (KG)
Platform (30" x 94") - CM2033.	345 (157)
Platform (42" x 94") - CM2046/CM2546.	495 (225)
Platform (54" x 94") - CM2558.	650 (295)
Platform Extension - All Models.	110 (50)
Arm Assembly - CM2033/CM2046. (Includes Lift Cylinder)	1300 (590)
Arm Assembly - CM2546/CM2558. (Includes Lift Cylinder)	1800 (817)
Chassis - CM2033 w/Solid Tires.	1480 (671)
Chassis - CM2046 w/Solid Tires	1800 (817)
Chassis - CM2546 w/Solid Tires.	1800 (817)
Chassis - CM2546 w/Foam Filled Tires	1870 (848)
Chassis - CM2558 w/Solid Tires.	1940 (880)

7-11. CRITICAL STABILITY WEIGHTS.

WARNING

DO NOT REPLACE ITEMS CRITICAL TO STABILITY, SUCH AS BATTERIES OR SOLID TIRES, WITH ITEMS OF DIFFERENT WEIGHT OR SPECIFICATION. DO NOT MODIFY UNIT IN ANY WAY TO AFFECT STABILITY.

Table 7-3. Critical Stability Weights.

	CM2033	CM2046	CM2546	CM2558
Tires-Solid (each)	27 lb (12 kg)	27 lb (12 kg)	27 lb (12 kg)	27 lb (12 kg)
Motor/Pump Assembly	44 lb (20 kg)	44 lb (20 kg)	44 lb (20 kg)	44 lb (20 kg)
Batteries - Std. - Each	77 lb (35 kg)	77 lb (35 kg)	77 lb (35 kg)	77 lb (35 kg)
Batteries - Standard - Combined	308 lb (140 kg)	308 lb (140 kg)	308 lb (140 kg)	308 lb (140 kg)
Batteries - High Output - Each	N/A	120 lb (54 kg)	120 lb (54 kg)	120 lb (54 kg)
Batteries - High Output - Combined	N/A	480 lb (218 kg)	480 lb (218 kg)	480 lb (218 kg)

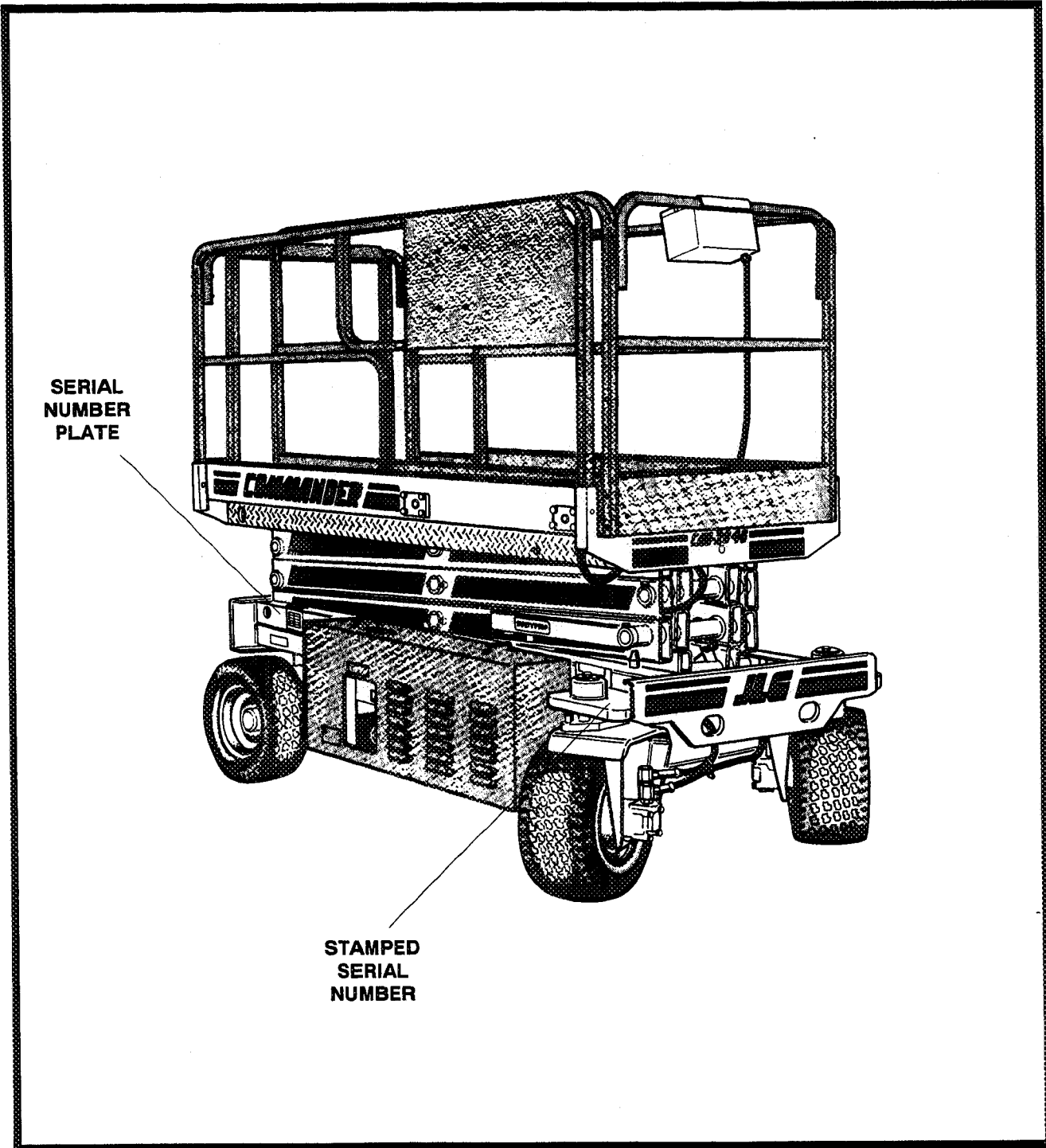

Figure 7-3. Serial Number Locations.

8-1. GENERAL.

- a. This section provides information necessary to perform maintenance on the sizzor lift. Descriptions, techniques and specific procedures are designed to provide the safest and most efficient maintenance for use by personnel responsible for ensuring the correct installation and operation of machine components and systems.

Note

Maintenance procedures provided in this section apply to all four sizzor lift models covered in this manual. Procedures that apply to a specific model will be so noted.

CAUTION

WHEN AN ABNORMAL CONDITION IS NOTED AND PROCEDURES CONTAINED HEREIN DO NOT SPECIFICALLY RELATE TO THE NOTED IRREGULARITY, WORK SHOULD BE STOPPED AND TECHNICALLY QUALIFIED GUIDANCE OBTAINED BEFORE WORK IS RESUMED.

- b. The maintenance procedures included consist of servicing and component removal and installation, disassembly and assembly, inspection, lubrication and cleaning. Information on any special tools or test equipment is also provided where applicable.

8-2. SERVICING AND MAINTENANCE GUIDELINES.**a. General.**

The following information is provided to assist you in the use and application of servicing and maintenance procedures contained in this chapter.

b. Safety and Workmanship.

Your safety, and that of others, is the first consideration when engaging in the maintenance of equipment. Always be conscious of weight. Never attempt to move heavy parts without the aid of a mechanical device. Do not allow heavy objects to rest in an unstable position. When raising a portion of the equipment, ensure that adequate support is provided.

c. Cleanliness.

- (1). The most important single item in preserving the long service life of a machine is to keep dirt and foreign materials out of the vital components. Precautions have been taken to safeguard against this. Shields, covers, seals, and filters are provided to

keep air, fuel, and oil supplies clean; however, these items must be maintained on a scheduled basis in order to function properly.

- (2). At any time when air, fuel, or oil lines are disconnected, clear adjacent areas as well as the openings and fittings themselves. As soon as a line or component is disconnected, cap or cover all openings to prevent entry of foreign matter.
- (3). Clean and inspect all parts during servicing or maintenance, and assure that all passages and openings are unobstructed. Cover all parts to keep them clean. Be sure all parts are clean before they are installed. New parts should remain in their containers until they are ready to be used.

d. Components Removal and Installation.

- (1). Use adjustable lifting devices, whenever possible, if mechanical assistance is required. All slings (chains, cables, etc.) should be parallel to each other and as near perpendicular as possible to top of part being lifted.
- (2). Should it be necessary to remove a component on an angle, keep in mind that the capacity of an eyebolt or similar bracket lessens, as the angle between the supporting structure and the component becomes less than 90 degrees.
- (3). If a part resists removal, check to see whether all nuts, bolts, cables, brackets, wiring, etc., have been removed and that no adjacent parts are interfering.

e. Component Disassembly and Reassembly.

When disassembling or reassembling a component, complete the procedural steps in sequence. Do not partially disassemble or assemble one part, then start on another. Always recheck your work to assure that nothing has been overlooked. Do not make any adjustments, other than those recommended, without obtaining proper approval.

f. Pressure-Fit Parts.

When assembling pressure-fit parts, use an "anti-seize" or molybdenum disulfide base compound to lubricate the mating surface.

g. Bearings.

- (1). When a bearing is removed, cover it to keep out dirt and abrasives. Clean bear-

ings in nonflammable cleaning solvent and allow to drip dry. Compressed air can be used but do not spin the bearing.

- (2). Discard bearings if the races and balls (or rollers) are pitted, scored, or burned.
- (3). If bearing is found to be serviceable, apply a light coat of oil and wrap it in clean (waxed) paper. Do not unwrap reusable or new bearings until they are ready to install.
- (4). Lubricate new or used serviceable bearings before installation. When pressing a bearing into a retainer or bore, apply pressure to the outer race. If the bearing is to be installed on a shaft, apply pressure to the inner race.

h. Gaskets.

Check that holes in gaskets align with openings in the mating parts. If it becomes necessary to hand-fabricate a gasket, use gasket material or stock of equivalent material and thickness. Be sure to cut holes in the right location, as blank gaskets can cause serious system damage.

i. Bolt Usage and Torque Application.

- (1). Use bolts of proper length. A bolt which is too long will bottom before the head is tight against its related part. If a bolt is too short, there will not be enough thread area to engage and hold the part properly. When replacing bolts, use only those having the same specifications of the original, or one which is equivalent.
- (2). Unless specific torque requirements are given within the text, standard torque values should be used on heat-treated bolts, studs, and steel nuts, in accordance with recommended shop practices. (See Figure 7-1.)

j. Hydraulic Lines and Electrical Wiring.

Clearly mark or tag hydraulic lines and electrical wiring, as well as their receptacles, when disconnecting or removing them from the unit. This will assure that they are correctly reinstalled.

k. Hydraulic System.

- (1). Keep the system clean. If evidence of metal or rubber particles is found in the hydraulic system, drain and flush the entire system.
- (2). Disassemble and reassemble parts on clean work surface. Clean all metal parts

with non-flammable cleaning solvent. Lubricate components, as required, to aid assembly.

l. Lubrication.

Service applicable components with the amount, type, and grade of lubricant recommended in this manual, at the specified intervals. When recommended lubricants are not available, consult your local supplier for an equivalent that meets or exceeds the specifications listed.

m. Batteries.

Clean batteries, using a non-metallic brush and a solution of baking soda and water. Rinse with clean water. After cleaning, thoroughly dry batteries and coat terminals with an anti-corrosion compound.

n. Lubrication and Servicing.

Components and assemblies requiring lubrication and servicing are shown in Figure 7-2.

8-3. LUBRICATION INFORMATION.

a. Hydraulic System.

- (1). The primary enemy of a hydraulic system is contamination. Contaminants enter the system by various means, e.g., using inadequate hydraulic oil, allowing moisture, grease, filings, sealing components, sand, etc., to enter when performing maintenance, or by permitting the pump to cavitate due to insufficient system warm-up or leaks in the pump supply (suction) lines.
- (2). The design and manufacturing tolerances of the component working parts are very close, therefore, even the smallest amount of dirt or foreign matter entering a system can cause wear or damage to the components and generally results in faulty operation. Every precaution must be taken to keep hydraulic oil clean, including reserve oil in storage. Hydraulic system filters should be checked, cleaned, and/or replaced as necessary, at the specified intervals required in Figure 7-2. Always examine filters for evidence of metal particles.
- (3). Cloudy oils indicate a high moisture content which permits organic growth, resulting in oxidation or corrosion. If this condition occurs, the system must be drained, flushed, and refilled with clean oil.

- (4). It is not advisable to mix oils of different brands or types, except as recommended, as they may not contain the same required additives or be of comparable viscosities. Good grade mineral oils, with viscosities suited to the ambient temperatures in which the machine is operating, are recommended for use.

Note

Metal particles may appear in the oil or filters of new machines due to the wear-in of meshing components.

b. Hydraulic Oil.

- (1). Refer to Table 7-1 for recommendations for viscosity ranges.
- (2). JLG recommends Kendall Hyken 052 hydraulic oil, which has an SAE viscosity of 10W-20 and a viscosity index of 152 or, as an alternate, Mobilfluid 424, which has an SAE viscosity of 10W-30 and a viscosity index of 152. Kendall Hyken 052 and Mobilfluid 424 are fully compatible, and can be mixed as necessary.

Note

Start-up of hydraulic system with oil temperatures below -15 degrees F (-26 degrees C). Is not recommended. If it is necessary to start the system in a sub-zero environment, it will be necessary to heat the oil with a low density, 100VAC heater to a minimum temperature of -15 degrees F (-26 degrees C).

- (3). The only exception to the above is to drain and fill the system with Mobil DTE 11 oil or its equivalent. This will allow start up at temperatures down to -20 degrees F (-29 degrees C). However, use of this oil will give poor performance at temperatures above 120 degrees F (49 degrees C). Systems using DTE 11 oil should not be operated at temperatures above 200 degrees F (94 degrees C). under any condition.

c. Changing Hydraulic Oil.

- (1). Use of any of the recommended crankcase or hydraulic oils eliminates the need for changing the oil on a regular basis. However, filter elements must be changed after the first 40 hours of operation and every 250 hours thereafter. If it is necessary to change the oil, use only those oils meeting or exceeding the specifications appearing in this manual. If unable to obtain the same type of oil supplied with the machine, consult local supplier for assistance in selecting the proper equivalent. Avoid mixing petroleum and

synthetic base oils. JLG Industries recommends changing the hydraulic oil annually.

- (2). Use every precaution to keep the hydraulic oil clean. If the oil must be poured from the original container into another, be sure to clean all possible contaminants from the service container. Always clean the mesh element of the filter and replace the cartridge any time the system oil is changed.
- (3). While the unit is shut down, a good preventive maintenance measure is to make a thorough inspection of all hydraulic components, lines, fittings, etc., as well as a functional check of each system, before placing the machine back in service.

d. Lubrication Specifications.

Specified lubricants, as recommended by the component manufacturers, are always the best choice, however, multi-purpose greases usually have the qualities which meet a variety of single purpose grease requirements. Should any question arise regarding the use of greases in maintenance stock, consult your local supplier for evaluation. Refer to Table 7-2 for an explanation of the lubricant key designations appearing in the Lubrication Chart.

8-4. CYLINDERS - THEORY OF OPERATION.

- a. Cylinders are of the double acting type. The Lift and Steer systems incorporate double acting cylinders. A double acting cylinder is one that requires oil flow to operate the cylinder rod in both directions. Directing oil (by actuating the corresponding control valve to the piston side of the cylinder) forces the piston to travel toward the rod end of the barrel, extending the cylinder rod (piston attached to rod). When the oil flow is stopped, movement of the rod will stop. By directing oil to the rod side of the cylinder, the piston will be forced in the opposite direction and the cylinder rod will retract.
- b. A holding valve is used in the Lift circuit to prevent retraction of the cylinder rod should a hydraulic line rupture or a leak develop between the cylinder and its related control valve.

8-5. VALVES - THEORY OF OPERATION.

a. Solenoid Control Valves (Bang-Bang).

Control valves used are four-way three-position solenoid valves of the sliding spool design. When a circuit is activated and the control valve solenoid energizes, the spool is shifted and the corresponding work port opens to permit oil flow to the component in the selected circuit,

with the opposite work port opening to reservoir. Once the circuit is deactivated (control returned to neutral), the valve spool returns to neutral (center) and oil flow is then directed through the valve body and returns to reservoir. A typical control valve consists of the valve body, sliding spool, and two solenoid assemblies. The spool is machine fitted in the bore of the valve body. Lands on the spool divide the bore into various chambers, which, when the spool is shifted, align with corresponding ports in the valve body open to common flow. At the same time other ports would be blocked to flow. The spool is spring-loaded to center position, therefore when the control is released, the spool automatically returns to neutral, prohibiting any flow through the circuit.

b. Proportional Control Valves.

The proportional control valves provide a power output matching that required by the load. A small line connected to a load sensing port feeds load pressure back to a sequence valve. The sequence valve senses the difference between the load and pump outlet pressure, and varies the pump displacement to keep the difference constant. This differential pressure is applied across the valve's meter-in spool, with the effect that pump flow is determined by the degree of spool opening, independent of load pressure. Return lines are connected together, simplifying routing of return flow and to help reduce cavitation. Load sensing lines connect through shuttle valves to feed the highest load signal back to the sequence valve. Integral actuator port relief valves, anti-cavitation check valves, and load check valves are standard.

c. Relief Valves.

Main relief valves are installed at various points within the hydraulic system to protect associated systems and components against excessive pressure. Excessive pressure can be developed when a cylinder reaches its limit of travel and the flow of pressurized fluid continues from the system control. The relief valve provides an alternate path for the continuing flow from the pump, thus preventing rupture of the cylinder, hydraulic line or fitting. Complete failure of the system pump is also avoided by relieving circuit pressure. The relief valve is installed in the circuit between the pump outlet (pressure line) and the cylinder of the circuit, generally as an integral part of the system valve bank. Relief pressures are set slightly higher than the load requirement, with the valve diverting excess pump delivery back to the reservoir when operating pressure of the component is reached.

d. Crossover Relief Valves.

Crossover relief valves are used in circuits where the actuator requires an operating pressure lower than that supplied to the system. When the circuit is activated and the required pressure at the actuator is developed, the crossover relief diverts excess pump flow to the reservoir. Individual, integral reliefs are provided for each side of the circuit.

8-6. COMPONENT FUNCTIONAL DESCRIPTION.

a. Hydraulic Pump.

The main hydraulic pump is an integral part of the electric motor/pump assembly, located at the rear of the battery and ground control tray on the frame of the machine. The pump is a two-section pump that provides an output of 3.13 gpm (11.8 lpm) from each pump section.

b. Accumulator. (Cushion Cylinder)

The accumulator is located on the rear of the battery and ground control tray on the frame of the machine. The accumulator is a cylinder with an orifice at each end to restrict the flow of hydraulic fluid through the cylinder. The accumulator is mounted inline in the drive circuit and serves to "smooth" acceleration and deceleration of the machine.

c. Lift Cylinder Holding/Manual Descent Valve.

The lift cylinder holding/manual descent valve is located on top of the lift cylinder. The holding valve is a normally closed solenoid valve which holds the platform in place when raised. When activated, the valve opens to permit lift down. A cable is connected to the solenoid valve which, when pulled, manually opens the lift down port of the valve and allows the platform to be lowered in the event hydraulic power is lost.

d. Positive Traction Valve.

The positive traction solenoid valve is located on the main control valve and is activated by a toggle switch on the platform control box. When activated, it equally divides the flow of hydraulic oil in the drive circuit to send an equal amount of oil to each drive motor.

8-7. WEAR PADS.

a. Sliding Pads.

The original thickness of the sliding pads is 3.56 inches (90 mm). Replace sliding pads when worn to 3.25 inches (83 mm).

8-8. CYLINDER CHECKING PROCEDURES.**Note**

Cylinder checks must be performed any time a cylinder component is replaced or when improper system operation is suspected.

- a. **Cylinder w/o Counterbalance Valves - Brake Cylinder, Steer Cylinder, Cushion Cylinder (Accumulator).**

IMPORTANT

OPERATE FUNCTIONS FROM GROUND CONTROL STATION ONLY.

WARNING

DO NOT FULLY EXTEND CYLINDER TO END OF STROKE. RETRACT CYLINDER SLIGHTLY TO AVOID TRAPPING PRESSURE.

- (1). Using all applicable safety precautions, activate motor and fully extend cylinder to be checked. Shut down motor.
- (2). Carefully disconnect hydraulic hose from retract port of cylinder. There will be initial weeping of hydraulic fluid which can be caught in a suitable container. After the initial discharge, there should be no further leakage from the retract port.
- (3). Activate motor and activate cylinder extend function. Check retract port for leakage.
- (4). If cylinder leakage is 6-8 drops per minute or more, piston seals are defective and must be replaced. If cylinder retract port leakage is less than 6-8 drops per minute, carefully reconnect hose to retract port and retract cylinder.
- (5). With cylinder fully retracted, shut down motor and carefully disconnect hydraulic hose from cylinder extend port.
- (6). Activate motor and activate cylinder retract function. Check extend port for leakage.
- (7). If cylinder leakage is 6-8 drops per minute or more, piston seals are defective and must be replaced. If extend port leakage is less than 6-8 drops per minute, carefully reconnect hose to extend port, then activate cylinder through one complete cycle and check for leaks.

- b. **Cylinders w/Single Counterbalance Valves - Lift Cylinder.**

IMPORTANT

OPERATE ALL FUNCTIONS FROM GROUND CONTROL STATION ONLY.

- (1). Using all applicable safety precautions, activate hydraulic system.

WARNINGS

WHEN WORKING ON THE LIFT CYLINDER, RAISE THE PLATFORM COMPLETELY AND SUPPORT THE PLATFORM USING A SUITABLE OVERHEAD LIFTING DEVICE.

DO NOT FULLY EXTEND LIFT CYLINDER TO END OF STROKE. RETRACT CYLINDER SLIGHTLY TO AVOID TRAPPING PRESSURE.

- (2). Raise platform completely then retract cylinder slightly to avoid trapping pressure. Place a suitable overhead lifting device approximately 1 inch (2.5 cm) below the platform.
- (3). Shut down hydraulic system and allow machine to sit for 10-15 minutes. Carefully remove hydraulic hoses from cylinder port block.
- (4). There will be initial weeping of hydraulic fluid, which can be caught in a suitable container. After the initial discharge, there should not be any further leakage from the ports. If leakage continues at a rate of 6-8 drops per minute or more, cylinder repairs must be made. If the retract port is leaking, the piston seals are defective and must be replaced. If the extend port is leaking, the counterbalance valve is defective and must be replaced.
- (5). If no repairs are necessary or when repairs have been made, carefully reconnect hydraulic hoses to the appropriate ports.
- (6). Remove lifting device from platform, activate hydraulic system and run cylinder through one complete cycle to check for leaks.

8-9. CYLINDER REMOVAL AND INSTALLATION.**a. Lift Cylinder Removal.**

- (1). Place the machine on a flat and level surface. Start the motor and raise the platform. Shut down the engine and at-

tach a suitable lifting device to the platform.

- (2). Remove the two bolts, lockwashers and hex nuts securing the cylinder rod attach pin to the upper inner arm assembly. Using a suitable brass drift, drive out the rod end attach pin from the arm assembly.
- (3). Retract the lift cylinder rod completely.
- (4). Tag and disconnect, then cap the lift cylinder hydraulic lines and ports.
- (5). Remove the two bolts securing one of the the barrel end attach pin retaining plates to the lower arm assembly. Using a suitable brass drift, drive out the barrel end attach pin from the arm assembly.
- (6). Carefully remove the cylinder from the Sizzor lift and place in a suitable work area.

d. Lift Cylinder Installation.

- (1). Install lift cylinder in place using suitable slings, aligning barrel end attach pin mounting holes on lower arm assembly.
- (2). Using a suitable drift, drive the barrel end attach pin through the mounting holes in the lift cylinder and the lower arm assembly. Secure in place with the pin retaining plate using the two bolts.
- (3). Remove cylinder port plugs and hydraulic line caps and correctly attach lines to cylinder ports.
- (4). Extend the cylinder rod until the attach pin hole aligns with those in the upper arm assembly. Using a suitable drift, drive the cylinder rod attach pin through the aligned holes, taking care to align the pin retaining holes with the stud on the turntable upright. Secure the pin in place with the two bolts, lockwashers and hex nuts.
- (5). Lower platform to stowed position and shut down motor. Check hydraulic fluid level and adjust accordingly.

8-10. CYLINDER REPAIR. (Except Brake Cylinder.)

Note

The following are general procedures that apply to all of the cylinders on this machine, except the brake cylinder. Procedures that apply to a specific cylinder will be so noted.

a. Disassembly.

IMPORTANT

DISASSEMBLY OF THE CYLINDER SHOULD BE PERFORMED ON A CLEAN WORK SURFACE IN A DIRT FREE WORK AREA.

- (1). Connect a suitable auxiliary hydraulic power source to the cylinder port block fitting.

WARNING

DO NOT FULLY EXTEND CYLINDER TO END OF STROKE. RETRACT CYLINDER SLIGHTLY TO AVOID TRAPPING PRESSURE.

- (2). Operate the hydraulic power source and extend the cylinder. Shut down and disconnect the power source. Adequately support the cylinder rod, if applicable.
- (3). If applicable, remove the cartridge-type holding valve and fittings from the cylinder port block. Discard o-rings.
- (4). Place the cylinder barrel into a suitable holding fixture.
- (5). Using a suitable spanner wrench, loosen the cylinder head retainer, if applicable, and/or cylinder head gland, and remove from cylinder barrel.
- (6). Attach a suitable pulling device to the cylinder rod port block end or cylinder rod end, as applicable.

IMPORTANT

EXTREME CARE SHOULD BE TAKEN WHEN REMOVING THE CYLINDER ROD, HEAD, AND PISTON. AVOID PULLING THE ROD OFF-CENTER, WHICH COULD CAUSE DAMAGE TO THE PISTON AND CYLINDER BARREL SURFACES.

- (7). With the barrel clamped securely, apply pressure to the rod pulling device and carefully withdraw the complete rod assembly from the cylinder barrel.

- (8). Using suitable protection, clamp the cylinder rod in a vise or similar holding fixture as close to the piston as possible.
- (9). Remove the set screw(s), if applicable, and nut which attach the piston to the rod, and remove the piston. Discard nylon point set screws.
- (10). Remove the piston rings.
- (11). Remove and discard the piston o-rings, seal rings, and backup rings.
- (12). Remove the set screw, if applicable, piston spacer, and wear ring, if applicable, from the rod.
- (13). Remove the rod from the holding fixture. Remove the cylinder head gland and retainer, if applicable. Discard the o-rings, back-up rings, rod seals, and wiper seals.

b. Cleaning and Inspection.

- (1). Clean all parts thoroughly in an approved cleaning solvent.
- (2). Inspect the cylinder rod for scoring, tapering, ovality, or other damage. If necessary, dress rod with Scotch Brite or equivalent. Replace rod if necessary.
- (3). Inspect threaded portion of rod for excessive damage. Dress threads as necessary.
- (4). Inspect inner surface of cylinder barrel tube for scoring or other damage. Check inside diameter for tapering or ovality. Replace if necessary.
- (5). Inspect threaded portion of barrel for damage. Dress threads as necessary.
- (6). Inspect piston surface for damage and scoring and for distortion. Dress piston surface or replace piston as necessary.
- (7). Inspect seal and o-ring grooves in piston for burrs and sharp edges. Dress applicable surfaces as necessary.
- (8). Inspect cylinder head inside diameter for scoring or other damage and for ovality and tapering. Replace as necessary.
- (9). Inspect seal and o-ring grooves in head for burrs and sharp edges. Dress applicable surfaces as necessary.
- (10). If applicable, inspect cylinder head retainer or end cap for surface or thread damage. Repair or replace as necessary.

- (11). Inspect cylinder head outside diameter for scoring or other damage and ovality and tapering. Replace as necessary.
- (12). If applicable, inspect thread ring for scoring or other damage. Dress threads or applicable surfaces as necessary.
- (13). If applicable, inspect rod and barrel bushings for signs of correct lubrication and excessive wear. Replace as necessary.
- (14). Inspect travel limiting collar or spacer for burrs and sharp edges. If necessary, dress inside diameter surface with Scotch Brite or equivalent.
- (15). If applicable, inspect port block fittings and holding valve. Replace as necessary.
- (16). Inspect the oil ports for blockage or the presence of dirt or other foreign material. Repair as necessary.
- (17). If applicable, inspect piston rings for cracks or other damage. Replace as necessary.

c. Assembly.

Notes

Prior to cylinder assembly, ensure that the proper cylinder seal kit is used. Refer to Section 11 of this manual.

Apply a light film of hydraulic oil to all components prior to assembly.

IMPORTANT

WHEN INSTALLING NEW "POLY-PAK" TYPE PISTON SEALS, ENSURE SEALS ARE INSTALLED PROPERLY. REFER TO FIGURE 2-1 FOR CORRECT SEAL ORIENTATION. IMPROPER SEAL INSTALLATION COULD RESULT IN CYLINDER LEAKAGE AND IMPROPER CYLINDER OPERATION.

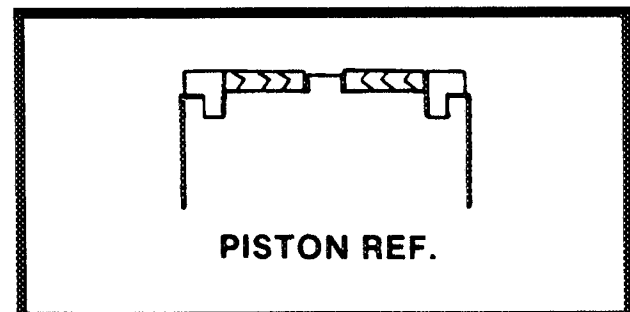

Figure 8-1. Poly-Pak Seal Installation.

- (1). Place a new wiper seal and rod seal into the applicable cylinder head gland grooves.
- (2). Carefully install the head gland on the rod, ensuring that the wiper and rod seals are not damaged or dislodged. Push the head along the rod to the rod end, as applicable.
- (3). Carefully slide the piston spacer on the rod. If applicable, align the oil holes in the rod and the spacer. Secure the spacer, if applicable.
- (4). If applicable, correctly place a new o-ring and back-up rings in the inner piston diameter groove.
- (5). Carefully place the piston on the cylinder rod, ensuring that the o-ring and back-up rings are not damaged or dislodged.
- (6). Using suitable protection, clamp the cylinder rod in a vise or similar holding fixture as close to the piston as possible.
- (7). Push the piston onto the rod until it abuts the spacer end and install the attaching nut.

WARNING

IF CYLINDER IS EQUIPPED WITH A PISTON NUT, APPLY "LOCQUIC PRIMER T" AND LOCTITE #242 TO PISTON NUT THREADS, THEN TIGHTEN NUT TO TORQUE SHOWN IN TABLE 8-1.

Note

Self-locking setscrews used on piston nuts should be discarded and replaced whenever they are removed.

- (8). If applicable, torque the piston nut to the proper torque as outlined in Table 8-1. Spot drill the piston rod at the point where the setscrew is inserted into the piston nut. Install the setscrew(s) which secure the piston attaching nut to the cylinder rod.
- (9). Remove the cylinder rod from the holding fixture.
- (10). Place new o-rings and seals in the applicable outside diameter grooves of both the piston and the cylinder head.
- (11). Position the cylinder barrel in a suitable holding fixture.

Table 8-1. Cylinder Piston Nut Torque Specifications.

Description	Nut Torque Value (w/Loctite)	Setscrew Torque Value (w/o Loctite)
Lift Cylinder	400 ft lb (542 Nm)	100 in lb (11 Nm)
Traversing Cylinder (If Equipped)	50 ft lb (68 Nm)	100 ft lb (11 Nm)

Table 8-2. Holding Valve Torque Specifications.

Description	Torque Value
Sun - 7/8 hex M20 x 1.5 thds	30-35 ft lb (41-48 Nm)
Sun - 1-1/8 hex 1 - 14 UNS thds	45-50 ft lb (61-68 Nm)
Sun - 1-1/4 hex M36 x 2 thds	150-160 ft lb (204-207 Nm)
Racine - 1-1/8 hex 1-1/16 - 12 thds	50-55 ft lb (68-75 Nm)
Racine - 1-3/8 hex 1-3/16 - 12 thds	75-80 ft lb (102-109 Nm)
Racine - 1-7/8 hex 1-5/8 - 12 thds	100-110 ft lb (136-149 Nm)

IMPORTANT

EXTREME CARE SHOULD BE TAKEN WHEN INSTALLING THE CYLINDER ROD, HEAD, AND PISTON. AVOID PULLING THE ROD OFF-CENTER, WHICH COULD CAUSE DAMAGE TO THE PISTON AND CYLINDER BARREL SURFACES.

- (12). With barrel clamped securely, and while adequately supporting the rod, insert the piston end into the barrel cylinder. Ensure that the piston loading o-ring and seal ring are not damaged or dislodged.
- (13). Continue pushing the rod into the barrel until the cylinder head gland can be inserted into the cylinder barrel.
- (14). If applicable, secure the cylinder head retainer using a suitable spanner type wrench.
- (15). After the cylinder has been reassembled, the rod should be pushed all the way in (fully retracted) prior to the reinstallation of any holding valve or valves.
- (16). If applicable, install the cartridge-type holding valve and fittings in the port block using new o-rings as applicable.

8-11. BRAKE CYLINDER REPAIR. (See Figure 8-2.)

a. Disassembly.

IMPORTANT

DISASSEMBLY OF THE CYLINDER SHOULD BE PERFORMED ON A CLEAN WORK SURFACE IN A DIRT FREE WORK AREA.

- (1). Tag and disconnect the hoses from the cylinder ports.

WARNING

DO NOT FULLY EXTEND CYLINDER TO END OF STROKE. RETRACT CYLINDER SLIGHTLY TO AVOID TRAPPING PRESSURE.

- (2). Place the cylinder barrel (2) into a suitable holding fixture.

WARNING

THE BRAKE CYLINDER IS EQUIPPED WITH AN INTERNAL COMPRESSION SPRING (1), WHICH HAS A FORCE OF APPROXIMATELY 33 LB. (15 KG) WHEN COMPRESSED. USE EXTREME CAUTION WHEN REMOVING RETAINING RING (14) FROM CYLINDER BARREL.

- (3). Using a suitable pair of snap ring pliers, carefully remove the retaining ring (14) from the cylinder barrel. Use extreme caution when removing the retaining ring, as the internal compression spring (1) is under a tension of approximately 33 lb. (15 kg).
- (4). Attach a suitable pulling device to the cylinder rod end.

IMPORTANT

EXTREME CARE SHOULD BE TAKEN WHEN REMOVING THE CYLINDER ROD, HEAD, AND PISTON. AVOID PULLING THE ROD OFF-CENTER, WHICH COULD CAUSE DAMAGE TO THE PISTON AND CYLINDER BARREL SURFACES.

- (5). With the barrel clamped securely, apply pressure to the rod pulling device and carefully withdraw the complete rod assembly from the cylinder barrel.
- (6). Using suitable protection, clamp the cylinder rod (15) in a vise or similar holding fixture.

- (7). Remove the socket head bolt (4) securing the spacer (3) to the cylinder rod and remove the spacer.
- (8). Remove the piston (8) from the cylinder rod. Remove and discard the piston ring (6) and o-rings (5 and 7).
- (9). Carefully remove the head (12) from the cylinder rod. Remove and discard the o-ring (9), backup ring (10), rod seal (11), and wiper seal (13).
- (10). Remove the cylinder rod from the holding fixture.

b. Cleaning and Inspection.

- (1). Clean all parts thoroughly in an approved cleaning solvent.
- (2). Inspect the cylinder rod for scoring, tapering, ovality, or other damage. If necessary, dress rod with Scotch Brite or equivalent. Replace rod if necessary.
- (3). Inspect threaded portion of rod for excessive damage. Dress threads as necessary.
- (4). Inspect inner surface of cylinder barrel tube for scoring or other damage. Check inside diameter for tapering or ovality. Replace if necessary.
- (5). Inspect piston surface for damage and scoring and for distortion. Dress piston surface or replace piston as necessary.
- (6). Inspect seal and o-ring grooves in piston for burrs and sharp edges. Dress applicable surfaces as necessary.
- (7). Inspect cylinder head inside diameter for scoring or other damage and for ovality and tapering. Replace as necessary.
- (8). Inspect seal and o-ring grooves in head for burrs and sharp edges. Dress applicable surfaces as necessary.
- (9). Inspect cylinder head outside diameter for scoring or other damage and ovality and tapering. Replace as necessary.
- (10). Inspect spacer for burrs and sharp edges. If necessary, dress spacer surface with Scotch Brite or equivalent.
- (11). Inspect the oil ports for blockage or the presence of dirt or other foreign material. Repair as necessary.

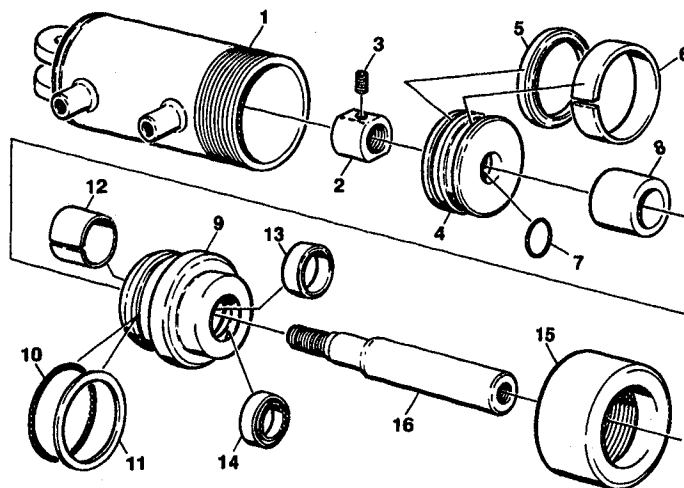

Prior to March 1992

- | | |
|--------------------|------------------|
| 1. Cylinder Barrel | 9. Head |
| 2. Nut | 10. O-Ring |
| 3. Setscrew | 11. Back-Up Ring |
| 4. Piston | 12. Wear Ring |
| 5. Piston Seal | 13. Rod Seal |
| 6. Wear Ring | 14. Wiper |
| 7. O-Ring | 15. Retainer |
| 8. Spacer Tube | 16. Rod |

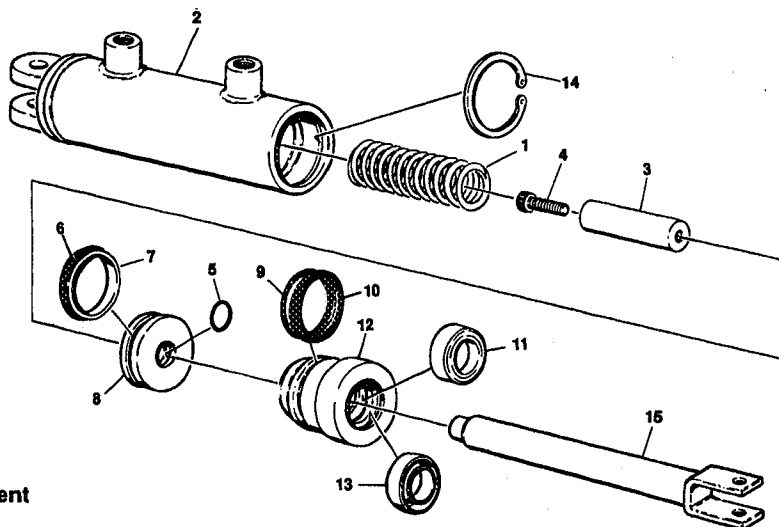

March 1992 to Present

- | | |
|-----------------------|--------------------|
| 1. Compression Spring | 9. O-Ring |
| 2. Cylinder Barrel | 10. Back-Up Ring |
| 3. Spacer | 11. Seal |
| 4. Socket Head Bolt | 12. Head |
| 5. O-Ring | 13. Wiper Ring |
| 6. Piston Ring | 14. Retaining Ring |
| 7. O-Ring | 15. Weldment Rod |
| 8. Piston | |

Figure 8-2. Brake Cylinder Assembly.

c. Assembly.**Notes**

Prior to cylinder assembly, ensure that the proper cylinder seal kit is used. Refer to Sections 11 and 13 of this manual.

Apply a light film of hydraulic oil to all components prior to assembly.

- (1). Using suitable protection, clamp the cylinder rod in a vise or similar holding fixture.
- (2). Place a new wiper seal (13), rod seal (11), o-ring (9), and back-up ring (10) into the applicable cylinder head grooves.
- (3). Carefully install the head on the rod, ensuring that the wiper and rod seals are not damaged or dislodged. Push the head onto the rod.
- (4). Place a new piston ring (6) and o-rings (5 and 7) on the piston.
- (4). Carefully place the piston on the cylinder rod, ensuring that the o-ring is not damaged or dislodged. Push the piston onto the rod until it abuts the head.
- (5). Install the spacer (3) on the end of the cylinder rod and secure in place with the socket head bolt (4).
- (6). Remove the cylinder rod from the holding fixture.
- (7). Position the cylinder barrel in a suitable holding fixture.

IMPORTANT

EXTREME CARE SHOULD BE TAKEN WHEN INSTALLING THE CYLINDER ROD, HEAD, AND PISTON. AVOID PULLING THE ROD OFF-CENTER, WHICH COULD CAUSE DAMAGE TO THE PISTON AND CYLINDER BARREL SURFACES.

- (12). Install the compression spring (1) on the piston end of the cylinder rod. With the barrel clamped securely, and while adequately supporting the rod, insert the piston end into the barrel cylinder. Ensure that the piston ring and o-ring are not damaged or dislodged.
- (13). Continue pushing the rod into the barrel until the cylinder head can be inserted into the cylinder barrel.
- (14). Using all applicable safety precautions, secure the cylinder rod assembly with a new retaining ring (14).

- (15). Reconnect the hydraulic hoses to the applicable cylinder ports.

8-12. TILT ALARM SWITCH. (If Equipped.)**Note**

The machine may be equipped with a tilt alarm switch (sensor), factory set to activate when the machine is out of level in any direction at 5 degrees and will cut out 2 speed drive. Consult factory for tilt sensor adjustment. The only field adjustment necessary is leveling the switch on the spring loaded studs. There are two methods of adjustment, a manual adjustment and an adjustment using a voltmeter.

CAUTION

PERFORM TILT ALARM SWITCH LEVELING PROCEDURE A MINIMUM OF EVERY SIX MONTHS TO ENSURE PROPER OPERATION AND ADJUSTMENT OF SWITCH.

a. Manual Adjustment.

- (1). Park the machine on a flat, level surface and ensure machine is level.

Note

Ensure switch mounting bracket is level and securely attached.

- (2). Level the base of the indicator by tightening the three flange nuts. Tighten each nut through approximately one half of it's spring's travel. **DO NOT ADJUST THE "X" NUT DURING THE REMAINDER OF THE PROCEDURE.**
- (3). With the electrical connections complete, slowly tighten one of the "Y" nuts until the circuit is closed and the light on the Platform Control Console illuminates.
- (4). Slowly back off the nut, counting the number of turns, until the circuit is again closed and the light again illuminates.
- (5). Divide the number of turns determined in step (4) in half. Tighten the nut this many turns. The line determined by this nut and the "X" nut is now parallel to the ground.
- (6). Repeat steps (3) through (5) for the remaining "Y" nut. The switch is now level.
- (7). Individually push down on one corner at a time; there should be enough travel to cause the switch to trip. If the switch does not trip in all three tests, the flange nuts have been tightened too far. Loosen the "X" nut and repeat steps (3) through (7).

b. Voltmeter Adjustment. (See Figure 8-2.)

- (1). Park machine on a flat, level surface and ensure machine is level.
- (2). If motor is not running, turn ignition switch to ON.
- (3). Connect black lead of voltmeter to ground and red lead to yellow wire protruding from pot on bottom of sensor.
- (4). Adjust leveling nuts to obtain the highest possible voltage reading.
- (5). Check voltage at trip point in all four directions. If voltage reading is not symmetrical, repeat step (4) above.

8-13. LIMIT SWITCH ADJUSTMENT.**a. Platform Limit Switch.**

The platform limit switch is located on the left side of the frame of the machine. The switch is activated when the platform is raised above the stowed position. When activated, the switch cuts out the High Drive function.

**8-14. PRESSURE SETTING PROCEDURES.
(See Figures 8-4 and 8-5.)****Notes**

Make all pressure adjustments with motor operating and hydraulic oil at normal operating temperature.

Drive is governed by P1. Steer and High Drive are governed by P2. On machines built before June 1993, Lift is controlled by P2. On machines built after June 1993, a separate Lift relief valve is provided.

a. Drive Relief Adjustment.

- (1). Install two pressure gauges, one at gauge port G1 and one at gauge port G2, by installing fittings in valve. G1 and G2 are located adjacent to the steer reliefs, and are identified by stampings on the valve body.
- (2). Disconnect tee fitting from drive tube (M3). Plug and cap tube and tee fitting.
- (3). Energize High Drive, Mid Drive and Drive Forward by positioning High Drive switch to HIGH and activate Drive switch to Drive Forward or by activating Drive controller to Drive Forward.

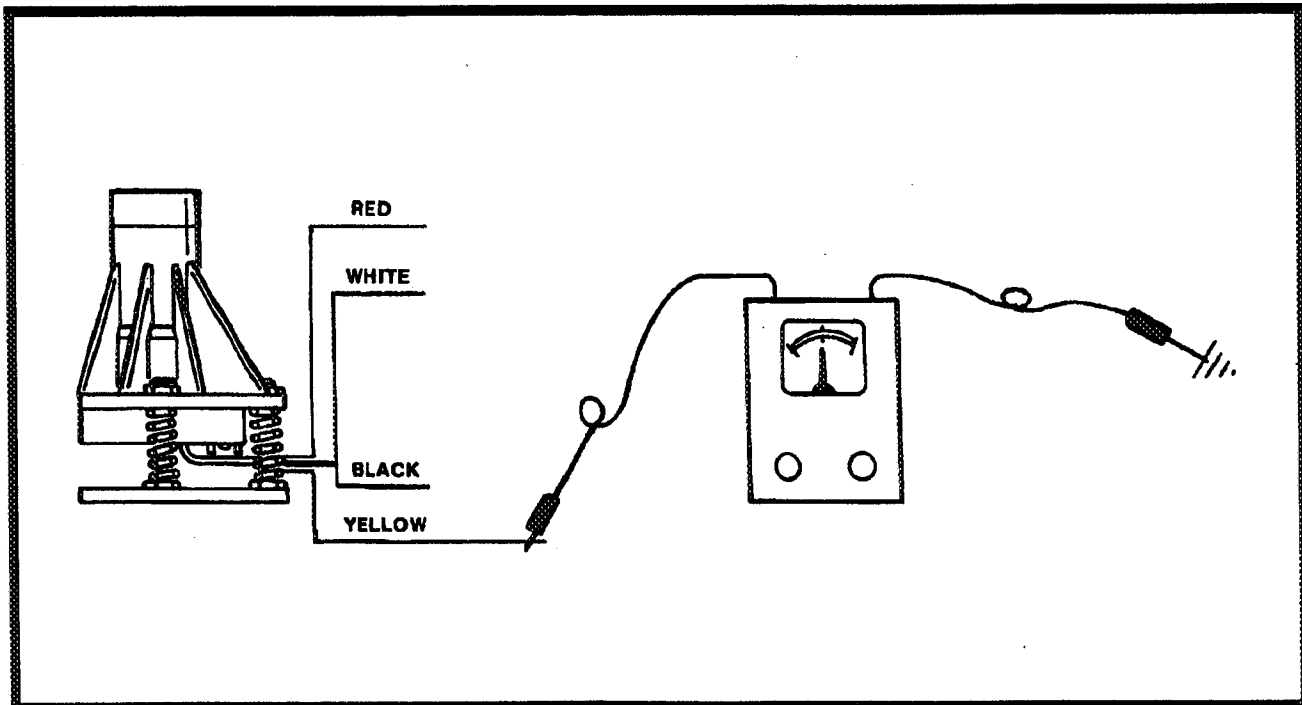

Figure 8-3. Tilt Alarm Switch Leveling - Voltmeter Adjustment.

- (4). On machine with bang-bang drive, adjust P1 to 2700 PSI (186 bar). On machines with proportional drive, adjust P1 to 2700 PSI (186 bar).
- (5). Replace tee fitting to drive tube.

b. Main Relief Adjustment.

Note

Machines built after June 1993 are equipped with a Lift relief valve. On these machines, before adjusting main relief, turn Lift relief valve adjustment all the way in (clockwise).

- (1). If equipped, turn Lift relief valve adjustment all the way in (clockwise).
- (2). Activate Lift Up function and bottom out Lift Up.
- (3). Adjust P2 to 2700 PSI (186 bar).

- (4). If equipped, turn Lift relief valve adjustment all the way out (counterclockwise). Adjust Lift relief valve in accordance with paragraph c.
- (5). Adjust Lift Down Speed Adjustment valve to 25-30 seconds for models CM2033 and CM2046, and 30-35 seconds for models CM2546 and CM2558.

**c. Lift Relief Adjustment.
(Machines Built After June 1993 Only.)**

- (1). Activate Lift Up function and bottom out Lift Up.
- (2). Adjust Lift relief valve as follows:
 CM2033 - 1800 PSI - (124 bar).
 CM2046 - 2150 PSI (148 bar).
 CM2546 - 2050 PSI (141 bar).
 CM2558 - 2300 PSI (159 bar).

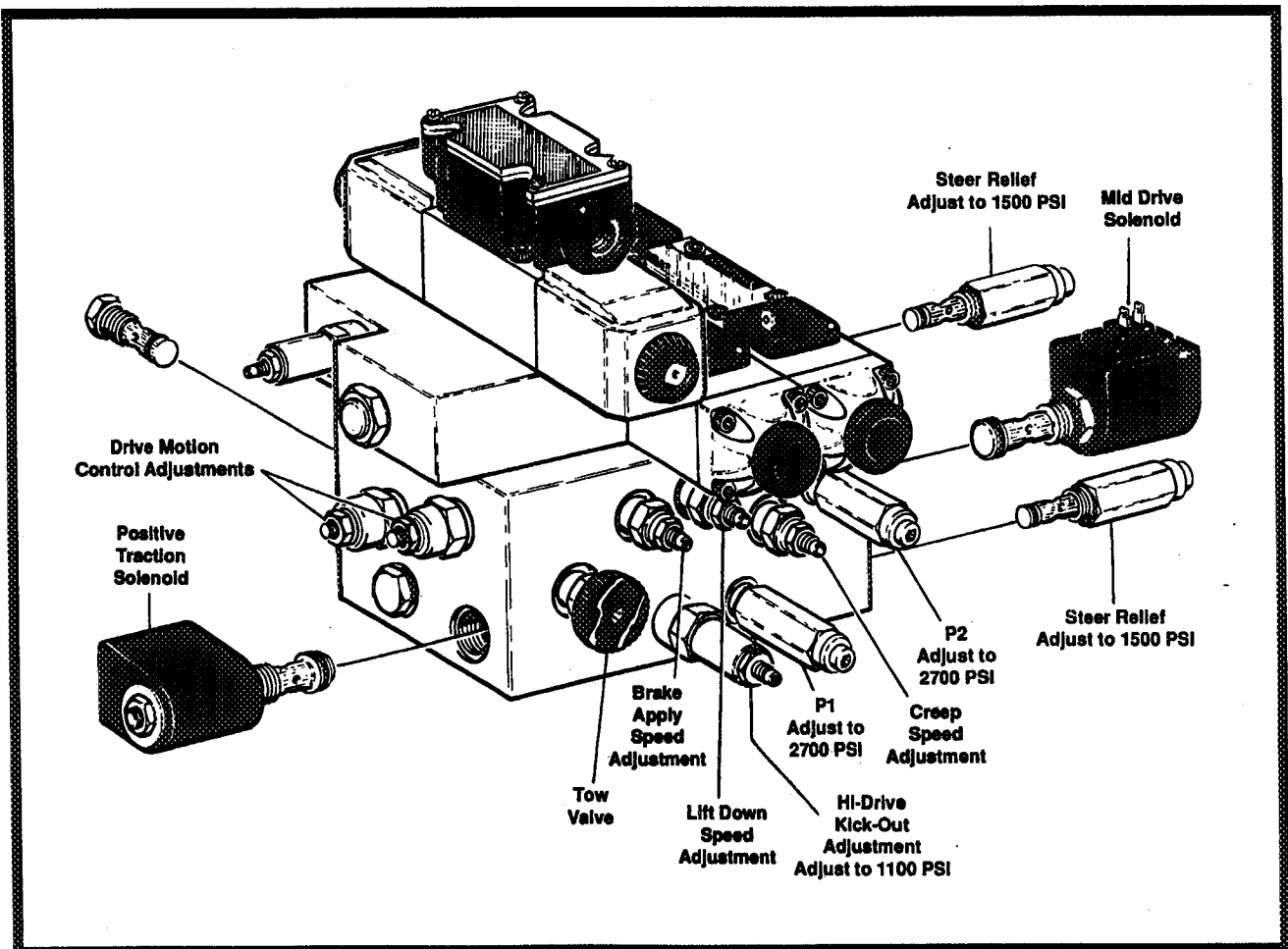

Figure 8-4. Pressure Adjustment Locations - Proportional Valve.

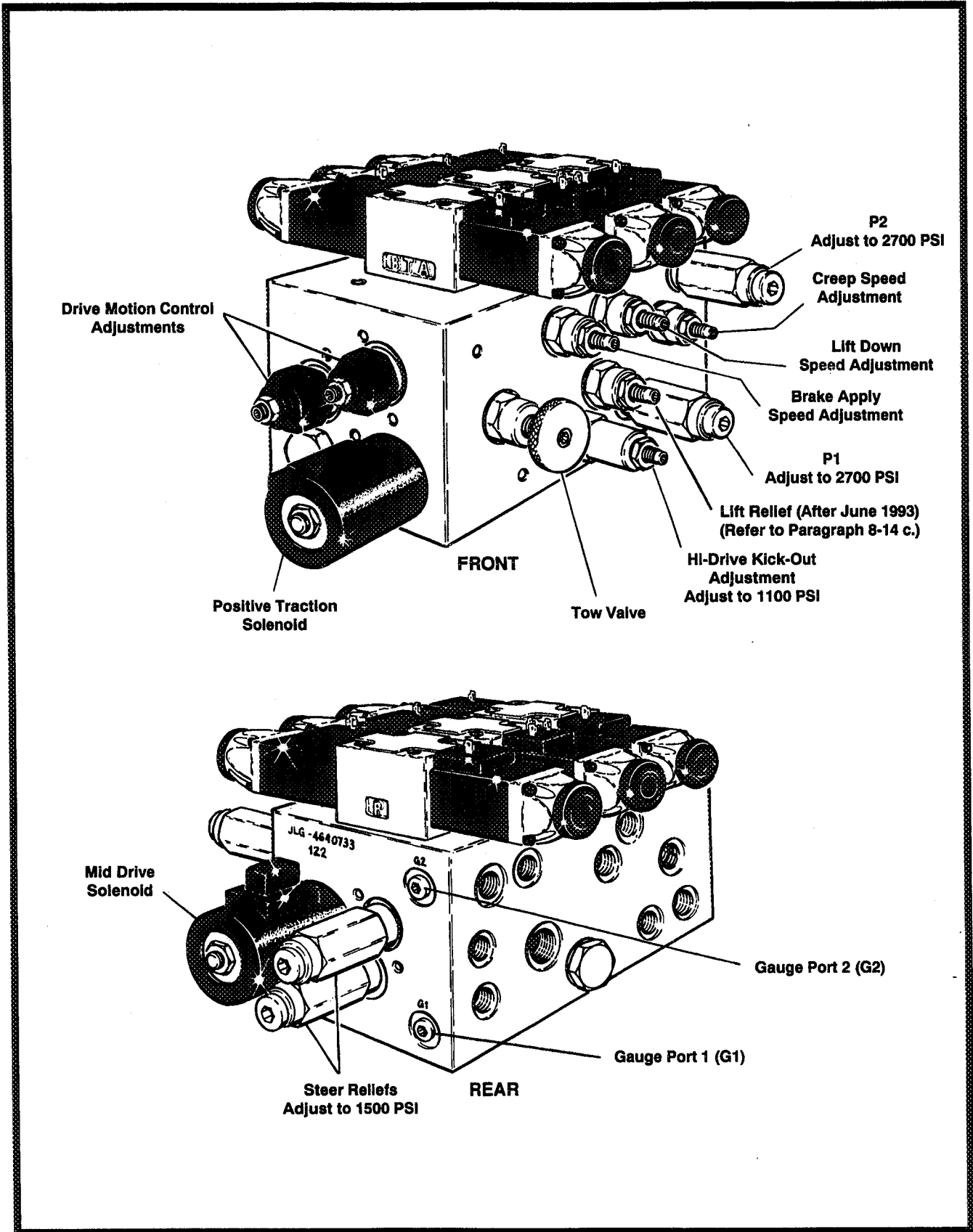

Figure 8-5. Pressure Adjustment Locations - Bang-Bang Valve.

d. High Drive Adjustment.

- (1). While monitoring pressure gauge at G2, active High Drive and traverse grade until High Drive shifts out. Adjust valve in until gauge at G2 reads 1100 PSI (76 bar) shifting in and out on grade. Stop at this point and lock adjustment screw.

e. Steer Adjustment.

- (1). While monitoring pressure gauge at G2, bottom out Steer Left and adjust S1 to 1500 PSI (103 bar).
- (2). While monitoring pressure gauge at G2, bottom out Steer Right and adjust S2 to 1500 PSI (103 bar).

Note

OC1 and OC2 are set at factory. If not functioning properly, they must be replaced.

8-15. PREVENTIVE MAINTENANCE AND INSPECTION SCHEDULE.

- a. The preventive maintenance and inspection checks are listed and defined in the following table. This table is divided into two basic parts, the "AREA" to be inspected and the "INTERVAL" at which the inspection is to take place. Under the "AREA" portion of the table, the various systems along with the components that make up that system are listed. The "INTERVAL" portion of the table is divided into five columns representing the various inspection time periods. The numbers listed within the interval column represent the applicable inspection code for which that component is to be checked.
- b. The checks and services listed in this schedule are not intended to replace any local or regional regulations that may pertain to this type of equipment nor should the lists be considered as all inclusive. Variances in interval times may occur due to climate and/or conditions and depending on the location and use of the machine.
- c. JLG Industries requires that a complete annual inspection be performed in accordance with the "Annual Machine Inspection Report" form. Forms are supplied with each new machine and are also available from JLG Customer Service. Form must be completed and returned to JLG Industries.

IMPORTANT

JLG INDUSTRIES REQUIRES THAT A COMPLETE ANNUAL INSPECTION BE PERFORMED IN ACCORDANCE WITH THE "ANNUAL MACHINE INSPECTION REPORT" FORM.

Note

This machine requires periodic safety and maintenance inspections be a JLG Dealer. A decal located on the frame affords a place to record (stamp) inspection dates. Notify dealer if inspection is overdue.

d. The inspection and maintenance code numbers are as follows:

1. Check for proper and secure installation.
2. Check for visible damage and legibility.
3. Check for proper fluid level.
4. Check for any structural damage; cracked or broken welds; bent or warped surfaces.
5. Check for leakage.
6. Check for presence of excessive dirt or foreign material.
7. Check for proper operation and freedom of movement.
8. Check for excessive wear or damage.
9. Check for proper tightness and adjustment.
10. Drain, clean and refill.
11. Check for proper operation while pump/motor is running.
12. Check for proper lubrication.
13. Check for evidence of scratches, nicks or rust and for straightness of rod.
14. Check for condition of element; replace as necessary.
15. Check for proper inflation.
16. Check Inspection Decal for current inspection stamp.

Table 8-3. Preventive Maintenance and Inspection Schedule.

PREVENTIVE MAINTENANCE AND INSPECTION SCHEDULE					
AREA	INTERVAL				
PLATFORM	(10 HRS) DAILY	(50 HRS) WEEKLY	(200 HRS) MONTHLY	(500 HRS) 3 MONTH	(1000 HRS) 6 MONTH
1. Controller (If Equipped)	1,11				
2. Switches	1,11				
3. Placards and Decals	1,2				
4. Control Tags	1,2				
5. Hose and Cable		4,8			
6. Wear Pads			8		
7. Handrail and Chains	1,4				
CHASSIS					
1. Batteries	3	5			
2. Battery Charger	1				
3. Hydraulic Pump/Motor	1	5			
4. Valves	1	5			
5. Hydraulic Filter (See Lubrication Chart)		5,14	14		
6. Hydraulic Hoses and Tubing	1	5			
7. Hydraulic Oil Tank *	3	5	4		
8. Hydraulic Tank Breather		6,14			
9. Lift Cylinder	1,12	5,6,13	4		
10. Limit Switch	1,7				
11. Placards and Decals	1,2				15
12. Wheel and Tire Assemblies	1	8,9			
13. Drive Motors		1,5,6			
14. Drive Brake		1,6	8		
15. Steer Cylinder	1	5,6,13	4		
16. Steer Components	1	4,6	8		
17. Wheel Bearings			8	12	
18. Sizzor Arms	1,4				
19. Safety Prop	1,4				
20. Wear Pads			8		
21. Pivot Pins/Bolts	1,4		7,8		
22. Switches, Ground Control	1,11				
23. Control Tags	1,2				
24. Placards and Decals	1,2				
25. Hose and Cable	1	4,8			

* Inspection and Maintenance Code 10 to be performed annually.

9-1. GENERAL.

- a. This section contains troubleshooting information to be used for locating and correcting most of the operating problems which may develop in the aerial platform. If a problem should develop which is not presented in this section or which is not corrected by listed corrective actions, technically qualified guidance should be obtained before proceeding with any maintenance.

9-2. TROUBLESHOOTING INFORMATION.

- a. The troubleshooting procedures applicable to the aerial platform are listed and defined in Tables 9-1 through 9-4. As an aid to table use, the aerial platform is divided into four major groups, each covered separately within this section. These groups are as follows: platform elevation system, chassis, hydraulic system and electrical system.
- b. Each malfunction within an individual group or system is followed by a listing of probable causes which will enable determination of the applicable remedial action. The probable causes and the remedial action should, where possible, be checked in the order listed in the tables.
- c. It should be noted that there is no substitute for a thorough knowledge of the equipment and related systems.

- d. It should be recognized that the majority of the problems arising in the machine will be centered in the hydraulic and electrical systems. For this reason, every effort has been made to ensure that all likely problems in these areas are given the fullest possible treatment. In the remaining machine groups, only those problems which are symptomatic of greater problems which have more than one probable cause and remedy are included. This means that problems for which the probable cause and remedy may be immediately obvious are not listed in this section.

- e. The first rule for troubleshooting any circuit that is hydraulically operated and electrically controlled is to determine if the circuit is lacking hydraulic oil and electrical control power. This can be ascertained by overriding the bypass valve (mechanically or electrically) so that oil is available to the function valve, then overriding the function valve mechanically. If the function performs satisfactorily, the problem exists with the control circuit.

9-3. HYDRAULIC CIRCUIT CHECKS.

The first reference for improper function of a hydraulic system, where the cause is not immediately apparent, should be the Troubleshooting Chart. The best place to begin the problem analysis is at the power source (pump). Once it is determined that the pump is serviceable, then a systematic check of the circuit components, beginning with the control, would follow. For aid in troubleshooting, refer to Section 11, the Illustrated Parts List for hydraulic diagrams of the various circuits.

Table 9-1. Elevation System Troubleshooting.

TROUBLE	PROBABLE CAUSE	REMEDY
Platform Elevation System.		
No response to LIFT control switch.	ENABLE switch not activated.	Activate ENABLE switch.
	LIFT control switch not activated within three seconds after ENABLE switch is activated.	Re-activate ENABLE switch.
	ENABLE switch not functioning properly.	Replace ENABLE switch circuit card.
	LIFT control switch inoperative.	Repair or replace control switch.
	Hydraulic system oil low.	Replenish oil as necessary.
	Restricted or broken supply line on valve bank or hydraulic pump.	Clean, repair or replace line.
	Control valve not functioning properly.	Repair or replace valve.
	Lift cylinder not functioning properly.	Repair or replace cylinder.
	Hydraulic pump not functioning properly.	Repair or replace pump.
Platform will not raise.	ENABLE switch not activated.	Activate ENABLE switch.
	LIFT control switch not activated within three seconds after ENABLE switch is activated.	Re-activate ENABLE switch.
	ENABLE switch not functioning properly.	Replace ENABLE switch circuit card.
	Load capacity exceeded. (Personnel and/or equipment on platform.)	Reduce load. (Refer to capacity placard.)
	Hydraulic system oil low.	Replenish oil as necessary.
	Restricted or broken hydraulic line or fitting.	Clean, repair, or replace line or fitting.
	Control valve not functioning properly.	Repair or replace valve.
	Lift cylinder not functioning properly.	Repair or replace cylinder.
	Motor/Pump does not respond when LIFT control switch is moved to UP position.	Refer to Electrical System Troubleshooting Chart. No response to control switch.
No electrical signal being sent to LIFT UP control valve cartridge.	Refer to Electrical System Troubleshooting Chart. No response to control switch.	
Platform will not lower.	ENABLE switch not activated.	Activate ENABLE switch.
	LIFT control switch not activated within three seconds after ENABLE switch is activated.	Re-activate ENABLE switch.
	ENABLE switch not functioning properly.	Replace ENABLE switch circuit card.

Table 9-1. Elevation System Troubleshooting.

TROUBLE	PROBABLE CAUSE	REMEDY
Platform Elevation System. (cont.)		
Platform will not lower. (cont.)	No electrical signal sent to LIFT DOWN control valve cartridge.	Refer to Electrical System Troubleshooting Chart. No response to control switch.
	LIFT DOWN control valve cartridge not functioning properly.	Repair or replace LIFT DOWN control valve cartridge.
	Lift cylinder not functioning properly.	Repair or replace cylinder.
	Motor/Pump does not respond when LIFT control switch is moved to DOWN position.	Refer to Electrical System Troubleshooting chart. No response to control switch.
	No electrical signal being sent to LIFT DOWN control valve	Refer to Electrical System Troubleshooting chart. No response to control switch.
Platform raises and lowers erratically.	Hydraulic system oil low.	Replenish oil as required.
	Restricted or broken hydraulic line or fitting.	Clean or replace line.
	Lack of lubricant on lift cylinder attach pins.	Lubricate as required. (Refer to Lubrication Chart)
	Counterbalance valve on lift cylinder improperly adjusted or not functioning properly.	Replace valve.
	Control valve not functioning properly.	Repair or replace valve.
	Worn seals in lift cylinder.	Replace seals.
	Cylinder not functioning properly.	Repair or replace cylinder.
Platform drifts down.	Manual lowering valve not functioning properly.	Repair or replace valve.
	Worn seals in lift cylinder.	Replace seals.
	Holding valve on lift cylinder not functioning properly.	Repair or replace valve.
High Drive does not operate below horizontal.	Damaged wiring on limit switch.	Repair or replace wiring.
	Damaged limit switch.	Replace limit switch.

Table 9-2. Chassis Troubleshooting.

TROUBLE	PROBABLE CAUSE	REMEDY
Drive System.		
No response to DRIVE control switch or controller.	ENABLE switch not activated.	Activate ENABLE switch.
	DRIVE control switch or controller not activated within three seconds after ENABLE switch is activated.	Re-activate ENABLE switch.
	ENABLE switch not functioning properly.	Replace ENABLE switch circuit card.
	Hydraulic system oil low.	Replenish oil as necessary.
	Hydraulic pump not functioning properly.	Repair or replace pump.
	Restricted or broken pump supply line.	Clean, repair or replace line.
	Drive motor(s) not functioning properly.	Repair or replace motor(s).
	Damaged wiring on DRIVE control switch or controller.	Repair or replace wiring.
	DRIVE control switch or controller not functioning properly.	Replace switch.
	Drive brake not releasing.	Determine cause and repair or replace brake.
Machine drives erratically. (PQ Controller Drive.)	Microswitch on controller improperly adjusted.	Adjust microswitch on controller for proper operation.
Machine will not travel forward.	ENABLE switch not activated.	Activate ENABLE switch.
	DRIVE control switch or controller not activated within three seconds after ENABLE switch is activated.	Re-activate ENABLE switch.
	ENABLE switch not functioning properly.	Replace ENABLE switch circuit card.
	Hydraulic system oil low.	Replenish oil as necessary.
	Restricted or broken hydraulic line or fitting.	Clean, repair or replace line or fitting.
	Control valve not functioning properly.	Repair or replace valve.
	Drive motor(s) not functioning properly.	Repair or replace motor(s).
	Brake cylinder not functioning properly.	Repair or replace brake cylinder.
	Motor/Pump will not respond when DRIVE control is moved to FORWARD position.	Refer to Electrical System Troubleshooting Chart. No response to control switch.
	No electrical signal being sent to the Drive valve cartridge.	Refer to Electrical System Troubleshooting Chart. No response to control switch.
Machine will not travel in reverse.	See: Machine will not travel forward.	

Table 9-2. Chassis Troubleshooting.

TROUBLE	PROBABLE CAUSE	REMEDY
Drive System. (continued)		
High-Speed Drive function does not operate. (Toggle Switch Drive)	Loose or damaged wiring between DRIVE control and High Speed switch.	Ensure proper connection of wires. Using suitable test meter, perform continuity test on wiring between switches. Repair or replace wires as necessary.
	Defective high speed control switch.	Replace switch.
	Loose or damaged wire in control box wire harness.	Ensure proper connection of wire at the control switch. Using suitable test meter, perform continuity test on wire. Repair or replace harness as necessary.
	Loose or damaged wire between platform and high speed solenoid.	Ensure proper connection of wire at the platform and at the high speed solenoid. Using suitable test meter, perform continuity test on wire. Repair or replace harness as necessary.
	High speed solenoid not functioning properly.	Replace solenoid.
	Loose or damaged wires between high speed relay and high speed limit switch.	Ensure proper connection of wires between high speed relay and high speed limit switch. Using suitable test meter, perform continuity test on wires. Repair or replace wires as necessary.
	High speed limit switch not functioning properly.	Repair or replace limit switch.
	Loose or damaged wire in valve wiring harness.	Ensure proper connection of wires at terminal strip. Using suitable test meter, perform continuity test on wires. Repair or replace harness as necessary.
	Motor/pump assembly defective.	Replace motor/pump assembly.

Table 9-2. Chassis Troubleshooting.

TROUBLE	PROBABLE CAUSE	REMEDY	
Steering System. No response to STEER control switch or controller.	ENABLE switch not activated.	Activate ENABLE switch.	
	STEER control switch or controller not activated within three seconds after ENABLE switch is activated.	Re-activate ENABLE switch.	
	ENABLE switch not functioning properly.	Replace ENABLE switch circuit card.	
	Hydraulic system oil low.	Replenish oil as necessary.	
	Hydraulic system pressure too low.	Adjust pressure.	
	Damaged wiring on control switch, controller or solenoid valve.	See proper wiring diagram.	
	STEER control switch or controller not functioning properly.	Replace switch.	
	Restricted or broken hydraulic line on valve bank or hydraulic pump.	Clean, repair or replace line.	
	Control valve not functioning properly.	Repair or replace valve.	
	Steer cylinder not functioning properly.	Repair or replace cylinder.	
	Machine hard to steer or steering is erratic.	Hydraulic system oil low.	Replenish oil as necessary.
		Restricted hydraulic line or fitting.	Clean, repair or replace line or fitting.
		Lack of lubrication.	Lubricate as required. (Refer to Lubrication Chart.)
Restricted crossover relief valve.		Clean or replace valve.	
Steer system pressure low.		Adjust pressure.	
Bent steering linkage.		Repair or replace linkage as required.	
Hydraulic pump not functioning properly.		Repair or replace pump.	
Steer cylinder not functioning properly.		Repair or replace cylinder.	
Steering inoperative.		ENABLE switch not activated.	Activate ENABLE switch.
		STEER control switch or controller not activated within three seconds after ENABLE switch is activated.	Re-activate ENABLE switch.
	ENABLE switch not functioning properly.	Replace ENABLE switch circuit card.	
	Damaged wiring on control switch, controller or solenoid valve.	See proper wiring diagram.	
	Solenoid valve not functioning properly.	Repair or replace valve.	
	Control switch or controller not functioning properly.	Replace switch.	
	Relief valve improperly set or not functioning properly.	Reset, repair or replace valves as required.	
	Steer cylinder not functioning properly.	Repair or replace cylinder.	

Table 9-2. Chassis Troubleshooting.

TROUBLE	PROBABLE CAUSE	REMEDY	
Steering System. (cont.)			
Machine will not steer left or right.	ENABLE switch not activated.	Activate ENABLE switch.	
	STEER control switch or controller not activated within three seconds after ENABLE switch is activated.	Re-activate ENABLE switch.	
	ENABLE switch not functioning properly.	Replace ENABLE switch circuit card.	
	Wiring on STEER control switch or controller is damaged.	Repair or replace wiring.	
	Wiring on solenoid valve damaged.	Repair or replace wiring.	
	Coil in solenoid damaged.	Replace coil.	
	Bent cylinder rod.	Repair or replace cylinder.	
	Damaged steer linkage.	Repair or replace steer linkage.	
	Machine wanders; steering not firm.	Crossover relief valve set too low or not functioning properly.	Reset, repair or replace valve as required.
		Steer linkages loose.	Tighten linkage.
Steer wheel toe-in not set properly.		Adjust toe-in for 1/4 inch overall.	
Spindle bushings badly worn.		Replace bushings.	

Table 9-3. Hydraulic System Troubleshooting.

TROUBLE	PROBABLE CAUSE	REMEDY
Hydraulic System - General.		
Hydraulic pump noisy.	Air bubbles in oil. (Reservoir oil too low.)	Replenish oil as required.
	Oil filter dirty.	Clean and/or replace filter as necessary.
Pump cavitating. (Vacuum in pump due to oil starvation.)	Oil in reservoir low.	Replenish oil as necessary.
	Restricted reservoir air vent.	Clean vent.
	Oil viscosity too high.	Drain system and replace with recommended oil. (Refer to Hydraulic Oils.)
System overheating.	Oil viscosity too high.	Drain system and replace with recommended hydraulic oil.
	Main relief valve set too high.	Reset valve as required.
	Hydraulic system oil low.	Replenish oil as necessary.
Pump not delivering oil.	Defective pump on motor.	Repair or replace motor.
System pressure too low.	Main relief valve set too low.	Reset valve as required.
	Hydraulic pump not functioning properly.	Repair or replace pump.
	Leak in component, line or fitting.	Repair or replace component, line or fitting.
	Scored valve spool; scored cylinder.	Replace valve; replace cylinder.
System(s) operate erratically.	Sticking or binding valve cartridge, piston rod, etc.	Clean, repair or replace components as required.
	Hydraulic oil not at operating temperature.	Allow oil sufficient time to warm up.

Table 9-4. Electrical System Troubleshooting.

TROUBLE	PROBABLE CAUSE	REMEDY
Hand Controller.		
Valve will not function when handle is moved in either direction.	ENABLE switch not activated.	Activate ENABLE switch.
	Controller not activated within three seconds after ENABLE switch is activated.	Re-activate ENABLE switch.
	ENABLE switch not functioning properly.	Replace ENABLE switch circuit card.
	No electrical power to handle.	Check electrical input to hand controller (12V).
	No electrical power to valve.	Check electrical output of printed circuit board and electrical signal at the valve.
	Improper ground.	Check for proper grounding of handle.
Control Switches.		
No response to a function control switch.	ENABLE switch not activated.	Activate ENABLE switch.
	Control switch not activated within three seconds after ENABLE switch is activated.	Re-activate ENABLE switch.
	ENABLE switch not functioning properly.	Replace ENABLE switch circuit card.
	EMERGENCY STOP switch not positioned properly.	Place EMERGENCY STOP switch to "ON".
	POWER SELECTOR switch on GROUND control box not positioned properly.	Place POWER SELECTOR switch to PLATFORM or GROUND, as required.
	Battery charger connected and in service.	Disconnect battery charger.
	Circuit breaker open.	Determine and correct cause. Reset circuit breaker.
	Batteries defective or require charging.	Test batteries for serviceability. Replace or charge batteries as necessary.
	No voltage present at EMERGENCY STOP switch.	Check battery cable from battery bank to EMERGENCY STOP switch for proper connection or damage. Repair or replace cable as necessary.
	EMERGENCY STOP switch not functioning properly.	Replace switch.
No voltage supplied to electric motor start relay from EMERGENCY STOP switch.	Check battery cable from switch to relay for proper connection or damage. Repair or replace cable as necessary.	
No voltage input at terminal strip.	Check wire from battery bank to terminal strip for proper connection or damage. Repair or replace wire as necessary.	

Table 9-4. Electrical System Troubleshooting.

TROUBLE	PROBABLE CAUSE	REMEDY
Control Switches. (cont.)		
No response to a function control switch. (cont.)	No voltage present at circuit breaker.	Check wire from terminal strip to circuit breaker for proper connection or damage. Repair or replace wire as necessary.
	Defective circuit breaker.	Replace circuit breaker.
	No voltage present at charge relay.	Check wire from charge relay to terminal strip for proper connection or damage. Repair or replace wire as necessary.
	Defective charge relay.	Replace charge relay.
	No voltage supplied to terminal strip from charge relay.	Check wire from charge relay to terminal strip for proper connection or damage. Repair or replace wire as necessary.
	No voltage present at control box EMERGENCY STOP switch.	Unplug control box harness from platform receptacle. Check wire from applicable pin in plug to control box EMERGENCY STOP switch for proper connection. Using suitable test meter, perform continuity test on wire. Repair or replace harness as necessary.
	Defective EMERGENCY STOP switch in control box.	Replace EMERGENCY STOP switch.
	No voltage present at function control switch.	Check wiring from EMERGENCY STOP switch to function control switch for proper connection or damage. Repair or replace wiring as necessary.
	Defective function control switch.	Replace function control switch.
	No voltage present at applicable points of the terminal strip. (Note: Actuation of a function control switch should simultaneously send an electrical signal to two separate points on the terminal strip. One signal for activation of the control valve coil and another signal for the activation of the electric motor start relay.)	Unplug control box harness from platform receptacle. Check applicable wires for proper connection in control box, at control box plug, at platform receptacle and at terminal strip. Using suitable test meter, perform continuity check on wires. Repair or replace harness as necessary.
	No voltage present at applicable control valve coil.	Check applicable wire for proper connection at terminal strip, valve harness plug pin, valve harness receptacle pin and valve coil. Using suitable test meter, perform continuity test on wire. Repair or replace wire or harness as necessary.
	No voltage supplied from terminal strip to electric motor start relay.	Check applicable wire for proper connection at terminal strip, valve harness plug pin, valve harness receptacle pin and electric motor start relay. Using suitable test meter, perform continuity test on wire. Repair or replace wire or harness as necessary.

Table 9-4. Electrical System Troubleshooting.

TROUBLE	PROBABLE CAUSE	REMEDY
Control Switches. (cont.)		
No response to a function control switch. (cont.)	Defective electric motor start relay.	Replace electric motor start relay.
	No voltage supplied to motor from start relay.	Check battery cable from relay to motor for proper connection or damage. Repair or replace cable as necessary.
	Defective motor/pump assembly.	Replace motor/pump assembly.
Motor/Pump.		
Hydraulic pump/electric motor inoperative.	Batteries require charging or will not hold a charge.	Charge or replace batteries as required.
	ENABLE switch not activated.	Activate ENABLE switch.
	Control switch or controller not activated within three seconds after ENABLE switch is activated.	Re-activate ENABLE switch.
	ENABLE switch not functioning properly.	Replace ENABLE switch circuit card.
	Damaged wiring on control switch or controller.	Repair or replace wiring.
	Control switch not functioning properly.	Replace switch.
	Pump motor relay not functioning properly.	Repair or replace relay.
	Pump motor not functioning properly.	Repair or replace motor.

SECTION 10 RECOMMENDED SERVICE PARTS STOCK CM2033/CM2046/CM2546/CM2558

The following one year list will service each CM2033, CM2046, CM2546 or CM2558 Sizzor (built to current production as of printing date) with the most commonly used parts. For further information, contact the nearest JLG Representative Center listed on the front cover.

PART NO.	DESCRIPTION	QTY.
STANDARD		
0961615	Bushing, Bronze (Figure 11-1-1)	4
0961931	Bushing, Fiberglide (Figure 11-1-1)	2
2900699	Seal Kit - Drive Motor (Figure 11-1-2)	2
2900778	Bearing Kit - Rear Axle (Figure 11-1-3)	2
4360057	Limit Switch (Figure 11-1-4)	1
3740069	Relay (Figure 11-2-1 and 11-7-1))	4
7010639	Brush Set (Figure 11-2-1)	2
7010944	Flex Coupling Kit (Figure 11-2-1)	1
4360202	Switch, Toggle (Figure 11-2-1)	1
4360290	Switch, Key (Figure 11-2-1)	1
4360267	Block, Contact (Figure 11-2-1 and 11-4-6)	1
4360281	Block, Contact (Figure 11-2-1)	1
4360070	Breaker, Circuit (Figure 11-2-1)	1
4360155	Switch, Master (Figure 11-2-1)	1
2120072	Element, Filter (Figure 11-2-1)	4
1340052	Breather, Air (Figure 11-2-1)	1
7012726	Coil - Rexroth (Figure 11-2-3)	1
7012732	Coil - Rexroth (Figure 11-2-3)	1
7012725	Seal Kit - Rexroth Valve (Figure 11-2-3 and 11-2-4)	2
7012900	Coil - 20 Volt (Figure 11-2-3 11-2-4 and 11-2-5)	1
7012930	Check Valve Cartridge (Figure 11-2-3 and 11-2-4)	1
7010544	Flow Control Valve Cartridge (Figure 11-2-3 and 11-2-4)	1
7012933	Needle Valve Cartridge (Figure 11-2-3 and 11-2-4)	1
7004361	Load Control Valve Cartridge (Figure 11-2-3 and 11-2-4)	1
7012934	Sequence Valve Cartridge (Figure 11-2-3 and 11-2-4)	1
7012931	Relief Valve Cartridge (Figure 11-2-3 and 11-2-4)	1
7012932	Relief Valve Cartridge (Figure 11-2-3 and 11-2-4)	1
7012920	Solenoid Valve Cartridge (Figure 11-2-3 and 11-2-4)	1
7012919	Solenoid Valve Cartridge (Figure 11-2-3 and 11-2-4)	1
7012929	Flow Divider Valve Cartridge (Figure 11-2-3 and 11-2-4)	1
7011508	Fuse - 15 Amp (Figure 11-2-7)	1
7011509	Breaker, Circuit (Figure 11-2-7)	1
7011518	Controller (Figure 11-2-7)	1
0961481	Bushing, Bronze (Figure 11-3-1 and 11-3-2)	40
4360339	Switch, Push Button (Figure 11-4-7)	1
4360289	Switch, Push/Pull (Figure 11-4-7)	1
4360318	Switch, Toggle (Figure 11-4-7)	1
4360274	Switch, Push Button (Figure 11-4-7)	1
2901160	Seal Kit - Brake (Figure 11-5-2)	2
1060377	Cable, Pull (Figure 11-5-3)	1
4640381	Solenoid Holding Cartridge (Figure 11-5-3)	1
4640717	Pull Control Cartridge (Figure 11-5-3)	1
0961520	Bushing, Bronze - Lift Cylinder Rod (Figure 11-5-3)	1
0961519	Bushing, Bronze - Lift Cylinder Barrel (Figure 11-5-3)	1
2901178	Seal Kit - Steer Cylinder (Figure 11-5-5)	1
3990010	Diode - 6 Amp (Figure 11-7-1)	3

SECTION 10 RECOMMENDED SERVICE PARTS STOCK

SECTION 10 RECOMMENDED SERVICE PARTS STOCK CM2033/CM2046/CM2546/CM2558

The following one year list will service each CM2033, CM2046, CM2546 or CM2558 Sizzor (built to current production as printing date) with the most commonly used parts. For further information, contact the nearest JLG Representative Center listed on the front cover.

PART NO.	DESCRIPTION	QTY.
VARIABLE		
4360300	Limit Switch ((Standard on CM2046 and CM2558) (Figure 11-1-5)	1
4360300	Limit Switch (CM2033/CM2546 With Optional Tires) (Figure 11-1-5)	1
4360171	Tilt Sensor (Optional) (Figure 11-1-5)	1
7010511	Load Sensing Valve Cartridge (Proportional Drive) (Figure 11-2-4)	1
7012935	Check Valve Cartridge (Proportional Drive) (Figure 11-2-4)	1
7012308	Coil (Proportional Drive) (Figure 11-2-4)	1
7012311	Seal Kit (Proportional Drive) (Figure 11-2-4)	1
7012956	Solenoid Valve Cartridge (Hydraulically Extended Deck) (Figure 11-2-5)	1
7012957	Solenoid Valve Cartridge (Hydraulically Extended Deck) (Figure 11-2-5)	1
7012921	Check Valve Cartridge (Hydraulically Extended Deck) (Figure 11-2-5)	1
7012912	Relief Valve Cartridge (Hydraulically Extended Deck) (Figure 11-2-5)	1
7010540	Relief Valve Cartridge (Hydraulically Extended Deck) (Figure 11-2-5)	1
4360328	Switch, Toggle (Toggle Switch Drive) (Figure 11-4-7)	1
4360314	Switch, Toggle (Toggle Switch Drive) (Figure 11-4-7)	1
4360345	Switch, Toggle (Toggle Switch Drive - 2SPD) (Figure 11-4-7)	1
4360355	Switch, Toggle (Toggle Switch Drive - 3SPD) (Figure 11-4-7)	1
1600156	PQ Controller (PQ Bang-Bang Drive) (Figure 11-4-7)	1
1600160	PQ Controller (PQ Proportional Drive) (Figure 11-4-7)	1
2901165	Seal Kit - Lift Cylinder (CM2033 and CM2046) (Figure 11-5-3)	1
2901158	Seal Kit - Lift Cylinder (CM2546 and CM2558) (Figure 11-5-3)	1
7001608	Seal Kit - Platform Extension (Hydraulically Extended Deck Option) (Figure 11-5-4)	1

SECTION 11 ILLUSTRATED PARTS LIST

TABLE OF CONTENTS

FIGURE NO.	TITLE	PAGE NO.
SECTION 11-1 — FRAME		
11-1-1	Frame, Steering and Drive Installation	11-1-2
11-1-2	Drive Motor Assemblies	11-1-8
11-1-3	Rear Axle and Brake Installations (Prior to March 1992)	11-1-10
11-1-4	Rear Axle and Brake Installations (March 1992 to Present)	11-1-14
11-1-5	Frame Mounted Components Installation	11-1-16
SECTION 11-2 — GROUND COMPONENTS		
11-2-1	Covers, Controls, Tank and Valves Installation	11-2-2
11-2-2	Control Valve Assembly - Hydro-Air (Machines with Bang-Bang Drive Built Prior to June 1992)	11-2-8
11-2-3	Control Valve Assembly - Hydro-Air (Machines With Bang-Bang Drive Built June 1992 to Present)	11-2-12
11-2-4	Control Valve Assembly - Hydro Air (Machines With Proportional Drive)	11-2-16
11-2-5	Control Valve Assembly - Hydro Air (Hydraulically Extended Deck Option) . . .	11-2-20
11-2-6	Batteries and Chargers Installation	11-2-22
11-2-7	Battery Charger Assembly	11-2-26
11-2-8	UL Listed Components Installation - Ground Components	11-2-28
SECTION 11-3 — SIZZOR ARMS		
11-3-1	Sizzor Arms Installation - CM2033 and CM2046	11-3-2
11-3-2	Sizzor Arms Installation - CM2546 and CM2558	11-3-4
SECTION 11-4 — PLATFORM		
11-4-1	Standard Handrails and Accessories Installation	11-4-2
11-4-2	Optional Fold-Down Handrail Installations	11-4-8
11-4-3	Optional Extendable Deck Installation With Standard Handrails	11-4-12
11-4-4	Optional Extendable Deck Installation With Fold-Down Handrails	11-4-14
11-4-5	Optional Hydraulically Extended Deck Installation with Standard Handrails . .	11-4-16
11-4-5A	Optional Hydraulically Extended Deck Installation with Fold-Down Handrails .	11-4-18
11-4-6	Steel Platform Console Box Assembly	11-4-20
11-4-7	Molded Platform Console Box Assembly	11-4-24
SECTION 11-5 — CYLINDERS		
11-5-1	Brake Cylinder Assembly (Prior to March 1992)	11-5-2
11-5-2	Brake Cylinder Assembly (March 1992 to Present)	11-5-4
11-5-3	Lift Cylinder Sub-Assembly	11-5-6
11-5-4	Platform Extension Cylinder Assembly (Hydraulically Extended Deck Option)	11-5-10
11-5-5	Steer Cylinder Assembly	11-5-12
SECTION 11-6 — HYDRAULIC		
11-6-1	Hydraulic Diagram - Bang-Bang Drive	11-6-2
11-6-2	Hydraulic Diagram - Proportional Drive	11-6-6

SECTION 11 TABLE OF CONTENTS

SECTION 11 ILLUSTRATED PARTS LIST

TABLE OF CONTENTS

FIGURE NO.	TITLE	PAGE NO.
SECTION 11-7 — ELECTRICAL		
11-7-1	Electrical Diagrams and Components Chart	11-7-2
11-7-2	Electrical Diagram - Toggle Switch Drive	11-7-10
11-7-3	Electrical Diagram - PQ Controller Bang-Bang Drive	11-7-11
11-7-4	Electrical Diagram - PQ Controller Proportional Drive	11-7-12
11-7-5	Electrical Diagram - Circuit Cards	11-7-13
11-7-6	Main Electrical Connector and Tools	11-7-14
SECTION 11-8 — DECALS		
11-8-1	Decal Installation - Domestic	11-8-2
11-8-2	Decal Installation - Latin American	11-8-6
SECTION 11-9 — SPECIAL OPTIONS LIST		11-9-1

SECTION 11 TABLE OF CONTENTS

SECTION 11-1 FRAME

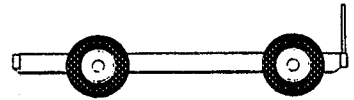

TABLE OF CONTENTS

FIGURE NO.	TITLE	PAGE NO.
11-1-1	Frame, Steering and Drive Installation	11-1-2
11-1-2	Drive Motor Assemblies	11-1-8
11-1-3	Rear Axle and Brake Installations (Prior to March 1992)	11-1-10
11-1-4	Rear Axle and Brake Installations (March 1992 to Present)	11-1-14
11-1-5	Frame Mounted Components Installation	11-1-16

**SECTION
11 - 1
FRAME**

SECTION 11-1 FRAME

FIGURE 11-1-1. FRAME, STEERING AND DRIVE INSTALLATION.

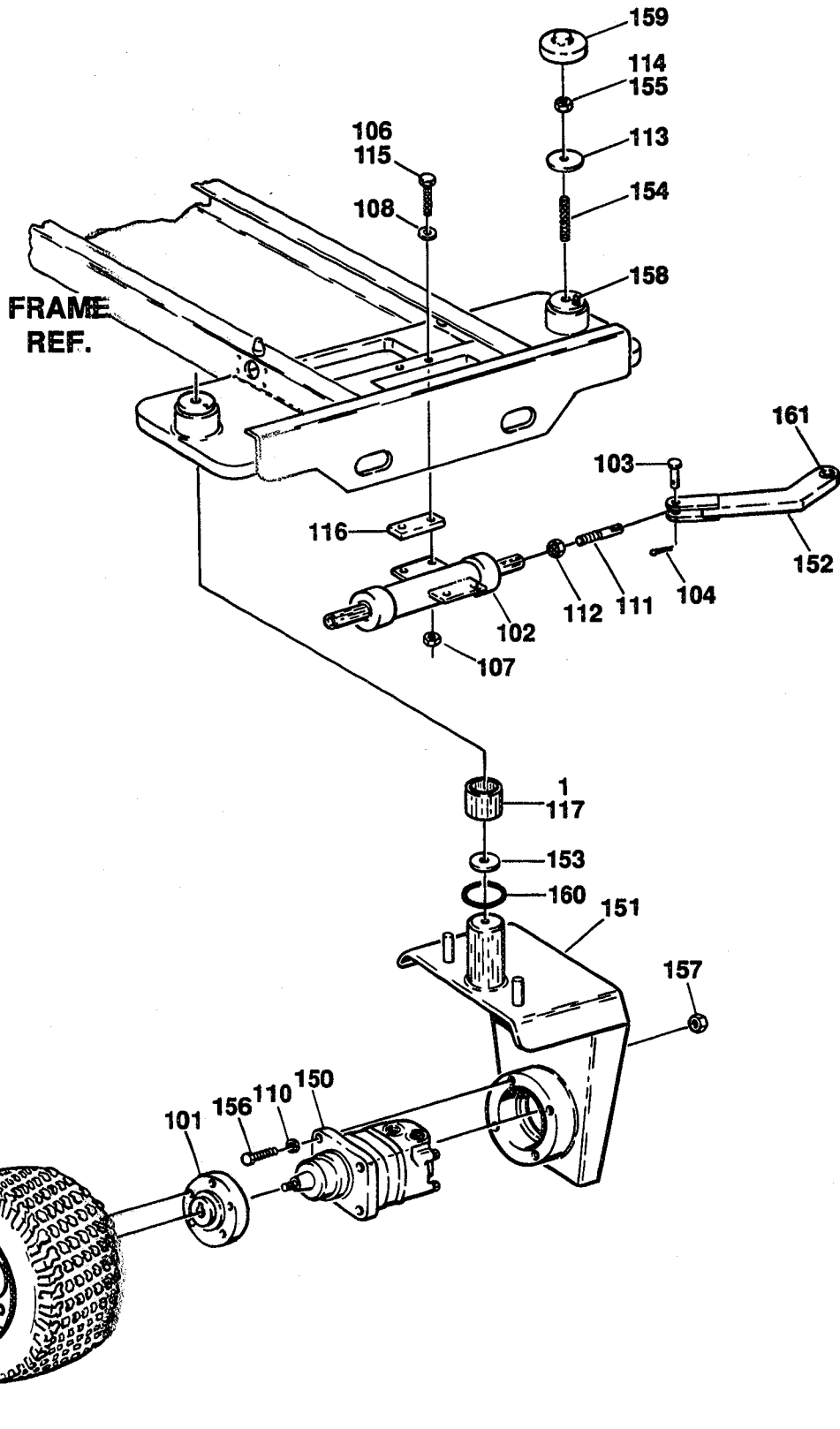
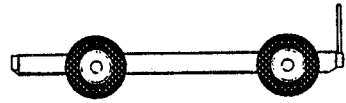

SECTION 11-1 FRAME

SECTION 11-1 FRAME

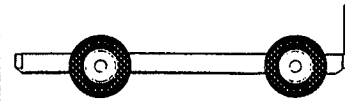

SECTION 11-1 FRAME

FIGURE & ITEM NO	PART NUMBER	DESCRIPTION	QTY.	REV.
11-1-1		FRAME, STEERING AND DRIVE INSTALLATION	Ref.	
		FRAME WELDMENTS (PRIOR TO MARCH 1992)	Ref.	
	2360323	Frame - Standard (Model CM2033)	1	
	2360342	Frame - Optional with Lifting Lugs (Model CM2033)	1	
	2360327	Frame - Standard (Models CM2046 and CM2546)	1	
	2360354	Frame - Optional with Lifting Lugs (Models CM2046 and CM2546)	1	
	2360328	Frame - Standard (Model CM2558)	1	
		All Frames Include:		
-1	0961482	Bushing, Bronze	2	
		FRAME WELDMENTS (MARCH 1992 TO PRESENT)	Ref.	
	2360343	Frame - Standard (Model CM2033)	1	
	2360346	Frame - Optional with Lifting Lugs (Model CM2033)	1	
	2360355	Frame - Standard (Model CM2046 and CM2546)	1	
	2360359	Frame - Optional with Lifting Lugs (Model CM2046 and CM2546)	1	
	2360356	Frame - Standard (Model CM2558)	1	
	2360362	Frame - Optional with Lifting Lug (Model CM2558)	1	
		All Frames Include:		
-1	0961615	Bushing, Bronze (Model CM2046, CM2546 and CM2558)	4	
	0961626	Bushing, Bronze (Model CM2033)	4	
		STEERING AND DRIVE INSTALLATION (STANDARD PARTS)	Ref.	
-101	2780165	Hub	2	
-102	1682996	Steer Cylinder Assembly - CM2033 Prior to August 1995 (See Section 11-5 for Breakdown)	1	
	1682997	Steer Cylinder Assembly - CM2046, CM2546 and CM2558 Prior to August 1995 (See Section 11-5 for Breakdown)	1	
	1683408	Steer Cylinder Assembly - All Machines August 1995 to Present (See Section 11-5 for Breakdown)	1	
-103	3430612	Pin, Clevis 3/8" (.8cm) x 1 1/2" (3.8cm)	2	
-104	3450404	Pin, Cotter 1/8" (.3cm) x 1" (2.5cm)	2	
-105	0630305	Bolt, Wheel	10	
-106	0641618	Bolt 3/8"-16NC x 2 1/4" (Front Location)	2	
-107	3311605	Locknut 3/8"-16NC	4	
-108	4711600	Flatwasher 3/8" Narrow	4	
-109	3450406	Pin, Cotter 1/8" (.3cm) x 1 1/2" (3.8 cm)	2	
-110	4761800	Lockwasher 1/2"	8	
-111	0361928	Rod, Adjusting	2	
-112	3322202	Nut, Jam 3/4"-16NF	2	
-113	4752000	Flatwasher 5/8"	2	
-114	0100011	Loctite	A/R	
-115	0641612	Bolt 3/8"-16NC x 1 1/2" (Rear Location)	2	
-116	4070769	Shim, Cylinder Mounting	1	
-117	3020010	Lubricant, "Neverseez"	A/R	

SECTION 11-1 FRAME



FIGURE & ITEM NO	PART NUMBER	DESCRIPTION	QTY.	REV.
11-1-1		FRAME, STEERING AND DRIVE INSTALLATION (CONTINUED)	Ref.	
	0251102	STEERING AND DRIVE INSTALLATION - MODEL CM2033 (PRIOR TO MARCH 1992) (VARIABLE PARTS)	Ref.	G
—150	3160173	Drive Motor Assembly (See Figure 11-1-2 for Breakdown)	2	
—151	4130238	Spindle Weldment	2	
—152	1360227	Clevis Weldment	2	
—153	4740375	Washer, Thrust	2	
—154	4300095	Stud 5/8"-11NC x 2 1/4"	2	
—155	3312005	Locknut 5/8"-11NC	2	
—156	0641816	Bolt 1/2"-13NC x 2"	8	
—157	3311801	Nut 1/2"-13NC	8	
—158	2160006	Fitting, Grease	2	
—159 to —161	Not Required			
	0252219	STEERING AND DRIVE INSTALLATION - MODEL CM2033 (MARCH 1992 TO AUGUST 1994) (VARIABLE PARTS) Note: S/N 12544, 12554-12557, 12574-12586, 12722-12748 machines built May-July 1994 use 1360261 clevis, 0961931 bushing and 4130269 spindle.	Ref.	C
—150	3160173	Drive Motor Assembly (See Figure 11-1-2 for Breakdown)	2	
—151	4130269	Spindle Weldment	2	
—152	1360227	Clevis Weldment (Use 1360261 Clevis and 0961931 Bushing as Replacement)	2	
—153	4740419	Washer, Thrust	2	
—154	4300093	Stud 3/8"-16NC x 2"	2	
—155	3311605	Locknut 3/8"-16NC	2	
—156	0641816	Bolt 1/2"-13NC x 2"	8	
—157	3311801	Nut 1/2"-13NC	8	
—158	Not Required			
—159	1120417	Cap, Plastic	2	
—160	Not Required			
—161	Not Required			
	0255021	STEERING AND DRIVE INSTALLATION - MODEL CM2033 AUGUST 1994 TO PRESENT) (VARIABLE PARTS)	Ref.	A
—150	3160173	Drive Motor Assembly (See Figure 11-1-2 for Breakdown)	2	
—151	4130321	Spindle Weldment	2	
—152	1360261	Clevis Weldment	2	
—153	4740419	Washer, Thrust	2	
—154	4300093	Stud 3/8"-16NC x 2"	2	
—155	3311605	Locknut 3/8"-16NC	2	
—156	0641816	Bolt 1/2"-13NC x 2"	8	
—157	3311801	Nut 1/2"-13NC	8	
—158	2160006	Fitting, Grease	2	
—159	1120417	Cap, Plastic	2	
—160	3780166	O-Ring	2	
—161	0961931	Bushing, Fiberglide	2	

SECTION 11-1 FRAME

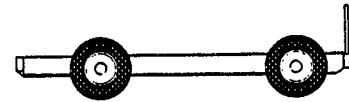

SECTION 11-1 FRAME

FIGURE & ITEM NO	PART NUMBER	DESCRIPTION	QTY.	REV.
11-1-1		FRAME, STEERING AND DRIVE INSTALLATION (CONTINUED)	Ref.	
	0251383	STEERING AND DRIVE INSTALLATION - MODEL CM2046 (PRIOR TO MARCH 1992) (VARIABLE PARTS)	Ref.	G
-150	3160173	Drive Motor Assembly (See Figure 11-1-2 for Breakdown)	2	
-151	4130241	Spindle Weldment	2	
-152	1360229	Clevis Weldment	2	
-153	4740375	Washer, Thrust	2	
-154	4300095	Stud 5/8"-11NC x 2 1/4"	2	
-155	3312005	Locknut 5/8" - 11NC	2	
-156	0641814	Bolt 1/2"-13NC x 1 3/4"	8	
-157	Not Required			
-158	2160006	Fitting, Grease	2	
-159 to -161	Not Required			
	0252701	STEERING AND DRIVE INSTALLATION - MODEL CM2046 (MARCH 1992 TO AUGUST 1994) (VARIABLE PARTS)	Ref.	C
-150	3160173	Drive Motor Assembly (See Figure 11-1-2 for Breakdown)	2	
-151	4130285	Spindle Weldment	2	
-152	1360229	Clevis Weldment (Use 1360262 Clevis and 0961931 Bushing as replacement)	2	
-153	4740418	Washer, Thrust	2	
-154	4300095	Stud 5/8"-11NC x 2 1/4"	2	
-155	3312005	Locknut 5/8"-11NC	2	
-156	0641814	Bolt 1/2"-13NC x 1 3/4"	8	
-157	Not Required			
-158	Not Required			
-159	1120418	Cap, Plastic	2	
-160	Not Required			
-161	Not Required			
	0255022	STEERING AND DRIVE INSTALLATION - MODEL CM2046 (AUGUST 1994 TO PRESENT) (VARIABLE PARTS)	Ref.	B
-150	3160173	Drive Motor Assembly (See Figure 11-1-2 for Breakdown)	2	
-151	4130323	Spindle Weldment	2	
-152	1360262	Clevis Weldment	2	
-153	4740418	Washer, Thrust	2	
-154	4300095	Stud 5/8"-11NC x 2 1/4"	2	
-155	3312005	Locknut 5/8"-11NC	2	
-156	0641814	Bolt 1/2"-13NC x 1 3/4"	8	
-157	Not Required			
-158	2160006	Fitting, Grease	2	
-159	1120418	Cap, Plastic	2	
-160	3760379	O-Ring	2	
-161	0961931	Bushing, Fiberglass	2	

SECTION 11-1 FRAME

SECTION 11-1 FRAME



FIGURE & ITEM NO	PART NUMBER	DESCRIPTION	QTY.	REV.
11-1-1		FRAME, STEERING AND DRIVE INSTALLATION (CONTINUED)	Ref.	
	0251384	STEERING AND DRIVE INSTALLATION - MODEL CM2546 (PRIOR TO MARCH 1992) (VARIABLE PARTS)	Ref.	F
-150	3160155	Drive Motor Assembly (See Figure 11-1-2 for Breakdown)	2	
-151	4130241	Spindle Weldment	2	
-152	1360229	Clevis Weldment	2	
-153	4740375	Washer, Thrust	2	
-154	4300095	Stud 5/8"-11NC x 2 1/4"	2	
-155	3312005	Locknut 5/8"-11NC	2	
-156	0641814	Bolt 1/2"-13NC x 1 3/4"	8	
-157	Not Required			
-158	2160006	Fitting, Grease	2	
-159 to -161	Not Required			
	0253094	STEERING AND DRIVE INSTALLATION - MODEL CM2546 (MARCH 1992 TO AUGUST 1994) (VARIABLE PARTS) Note: S/N 12712-12721 machines built May-July 1994 use 1360262 clevis, 0961931 bushing and 4130285 spindle.	Ref.	B
-150	3160155	Drive Motor Assembly (See Figure 11-1-2 for Breakdown)	2	
-151	4130285	Spindle Weldment	2	
-152	1360229	Clevis Weldment (Use 1360262 clevis and 0961931 bushing as replacement)	2	
-153	4740418	Washer, Thrust	2	
-154	4300095	Stud 5/8"-11NC x 2 1/4"	2	
-155	3312005	Locknut 5/8"-11NC	2	
-156	0641814	Bolt 1/2"-13NC x 1 3/4"	8	
-157	Not Required			
-158	Not Required			
-159	1120418	Cap, Plastic	2	
-160	Not Required			
-161	Not Required			
	0255023	STEERING AND DRIVE INSTALLATION - MODEL CM2546 (AUGUST 1994 TO PRESENT) (VARIABLE PARTS)	Ref.	C
-150	3160155	Drive Motor Assembly (See Figure 11-1-2 for Breakdown)	2	
-151	4130323	Spindle Weldment	2	
-152	1360262	Clevis Weldment	2	
-153	4740418	Washer, Thrust	2	
-154	4300095	Stud 5/8"-11NC x 2 1/4"	2	
-155	3312005	Locknut 5/8"-11NC	2	
-156	0641814	Bolt 1/2"-13NC x 1 3/4"	8	
-157	Not Required			
-158	2160006	Fitting, Grease	2	
-159	1120418	Cap, Plastic	2	
-160	3760379	O-Ring	2	
-161	0961931	Bushing, Fiberglide	2	

SECTION 11-1 FRAME



SECTION 11-1 FRAME

FIGURE & ITEM NO	PART NUMBER	DESCRIPTION	QTY.	REV.
11-1-1		FRAME, STEERING AND DRIVE INSTALLATION (CONTINUED)	Ref.	
	0251389	STEERING AND DRIVE INSTALLATION - MODEL CM2558 (PRIOR TO MARCH 1992) (VARIABLE PARTS)	Ref.	G
-150	3160155	Drive Motor Assembly (See Figure 11-1-2 for Breakdown)	2	
-151	4130242	Spindle Weldment	2	
-152	1360230	Clevis Weldment	2	
-153	4740375	Washer, Thrust	2	
-154	4300095	Stud 5/8"-11NC x 2 1/4"	2	
-155	3312005	Locknut 5/8"-11NC	2	
-156	0641814	Bolt 1/2"-13NC x 1 3/4"	8	
-157	Not Required			
-158	2160006	Fitting, Grease	1	
-159 to -161	Not Required			
	0252702	STEERING AND DRIVE INSTALLATION - MODEL CM2558 (MARCH 1992 TO AUGUST 1994) (VARIABLE PARTS)	Ref.	C
-150	3160155	Drive Motor Assembly (See Figure 11-1-2 for Breakdown)	2	
-151	4130284	Spindle Weldment	2	
-152	1360230	Clevis Weldment (Use 1360263 clevis and 0961931 bushing as replacement)	2	
-153	4740418	Washer, Thrust	2	
-154	4300095	Stud 5/8"-11NC x 2 1/4"	2	
-155	3312005	Locknut 5/8"-11NC	2	
-156	0641814	Bolt 1/2"-13NC x 1 3/4"	8	
-157	Not Used			
-158	Not Used			
-159	1120418	Cap, Plastic	2	
-160	Not Required			
-161	Not Required			
	0255024	STEERING AND DRIVE INSTALLATION - MODEL CM2558 (AUGUST 1994 TO PRESENT) (VARIABLE PARTS)	Ref.	B
-150	3160155	Drive Motor Assembly (See Figure 11-1-2 for Breakdown)	2	
-151	4130322	Spindle Weldment	2	
-152	1360263	Clevis Weldment (Use 1360263 clevis and 0961931 bushing as replacement)	2	
-153	4740418	Washer, Thrust	2	
-154	4300095	Stud 5/8"-11NC x 2 1/4"	2	
-155	3312005	Locknut 5/8"-11NC	2	
-156	0641814	Bolt 1/2"-13NC x 1 3/4"	8	
-157	Not Required			
-158	2160006	Fitting, Grease	2	
-159	1120418	Cap, Plastic	2	
-160	3760379	O-Ring	2	
-161	0961931	Bushing, Fiberglide		
		TIRE ASSEMBLY OPTIONS	Ref.	
-200	4520128	Tire - Solid (Standard)	4	
	4520165	Tire - Non-Marking (Optional)	4	
	4520167	Tire - Foam-Filled (Optional)	4	

SECTION 11-1 FRAME

FIGURE 11-1-2. DRIVE MOTOR ASSEMBLIES.

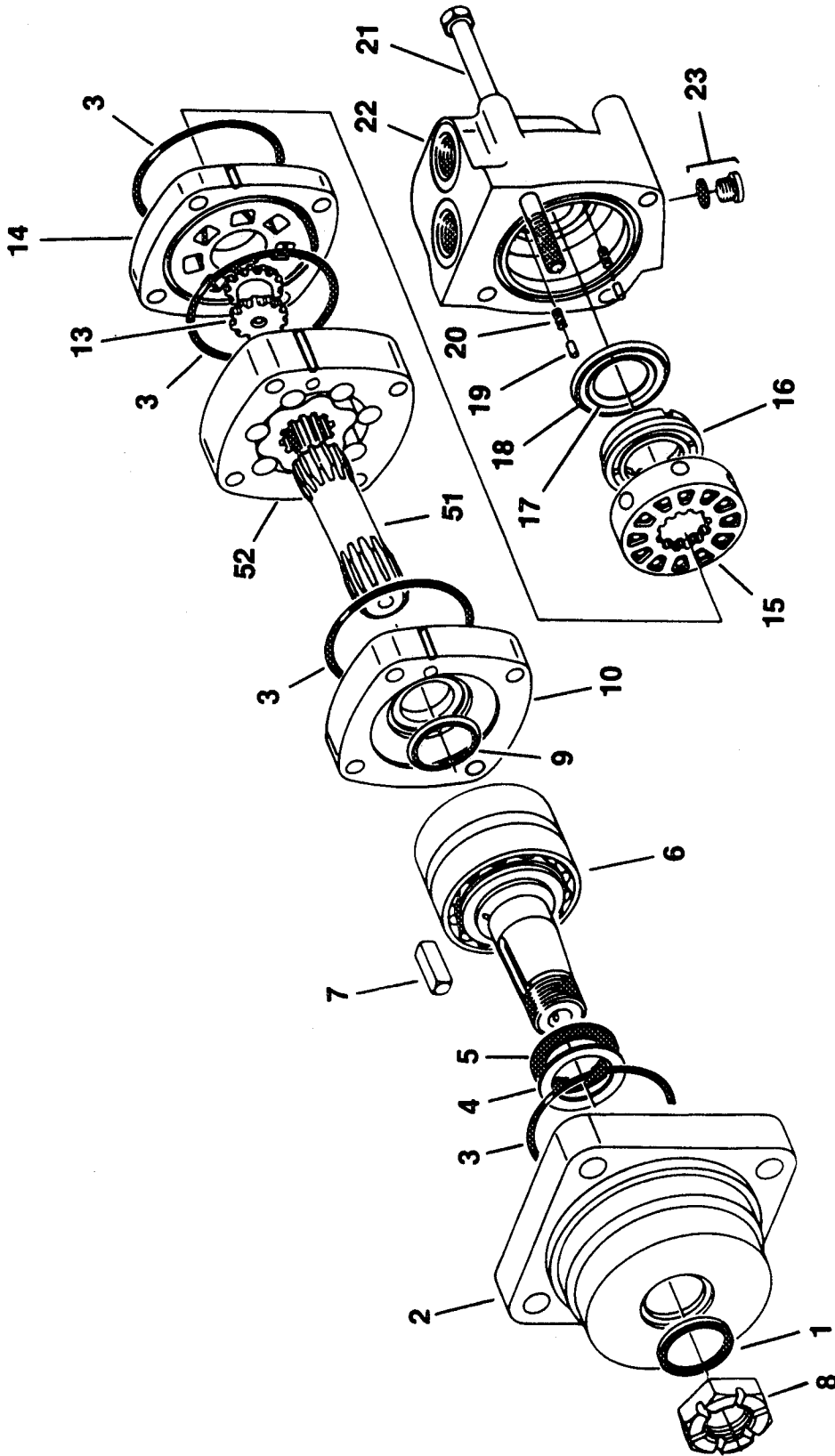
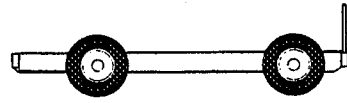

SECTION 11-1 FRAME



SECTION 11-1 FRAME

FIGURE & ITEM NO	PART NUMBER	DESCRIPTION	QTY.	REV.
11-1-2		DRIVE MOTOR ASSEMBLIES	Ref.	
		DRIVE MOTOR ASSEMBLIES (STANDARD PARTS)	Ref.	
-1	Kit	Seal, Dust	1	
-2	7009931	Housing, Bearing	1	
-3	Kit	Seal	4	
-4	Kit	Ring, Back-up	1	
-5	Kit	Seal, Shaft	1	
-6	7009932	Shaft and Bearing	1	
-7	7009933	Key	1	
-8	7009934	Nut, Castle	1	
-9	Kit	Seal, Shaft Face	1	
-10	7009982	Plate, Wear	1	
-11	Not Used			
-12	Not Used			
-13	7009905	Drive, Valve	1	
-14	7009983	Plate, Valve	1	
-15	7009927	Valve	1	
-16	7009909	Ring, Balance	1	
-17	Kit	Seal, Face - Inner	1	
-18	Kit	Seal, Face - Outer	1	
-19	7009912	Pin	2	
-20	7009913	Spring	2	
-21	7009929	Bolt	4	
-22	7009930	Housing, Valve	1	
-23	7002157	Plug Assembly	1	
	3160155	DRIVE MOTOR ASSEMBLIES - MODELS CM2546 AND CM2558 (VARIABLE PARTS)	Ref.	
-51	7009922	Drive	1	
-52	7009925	Geroler	1	
	3160173	DRIVE MOTOR ASSEMBLIES - MODELS CM2033 AND CM2046 (VARIABLE PARTS)	Ref.	
-51	7009979	Drive	1	
-52	7009980	Geroler	1	
	2900699	----- Seal Kit (Includes Items 1,3,4,5,9,17 and 18)	1	

SECTION 11-1 FRAME

FIGURE 11-1-3. REAR AXLE AND BRAKE INSTALLATIONS
(PRIOR TO MARCH 1992).

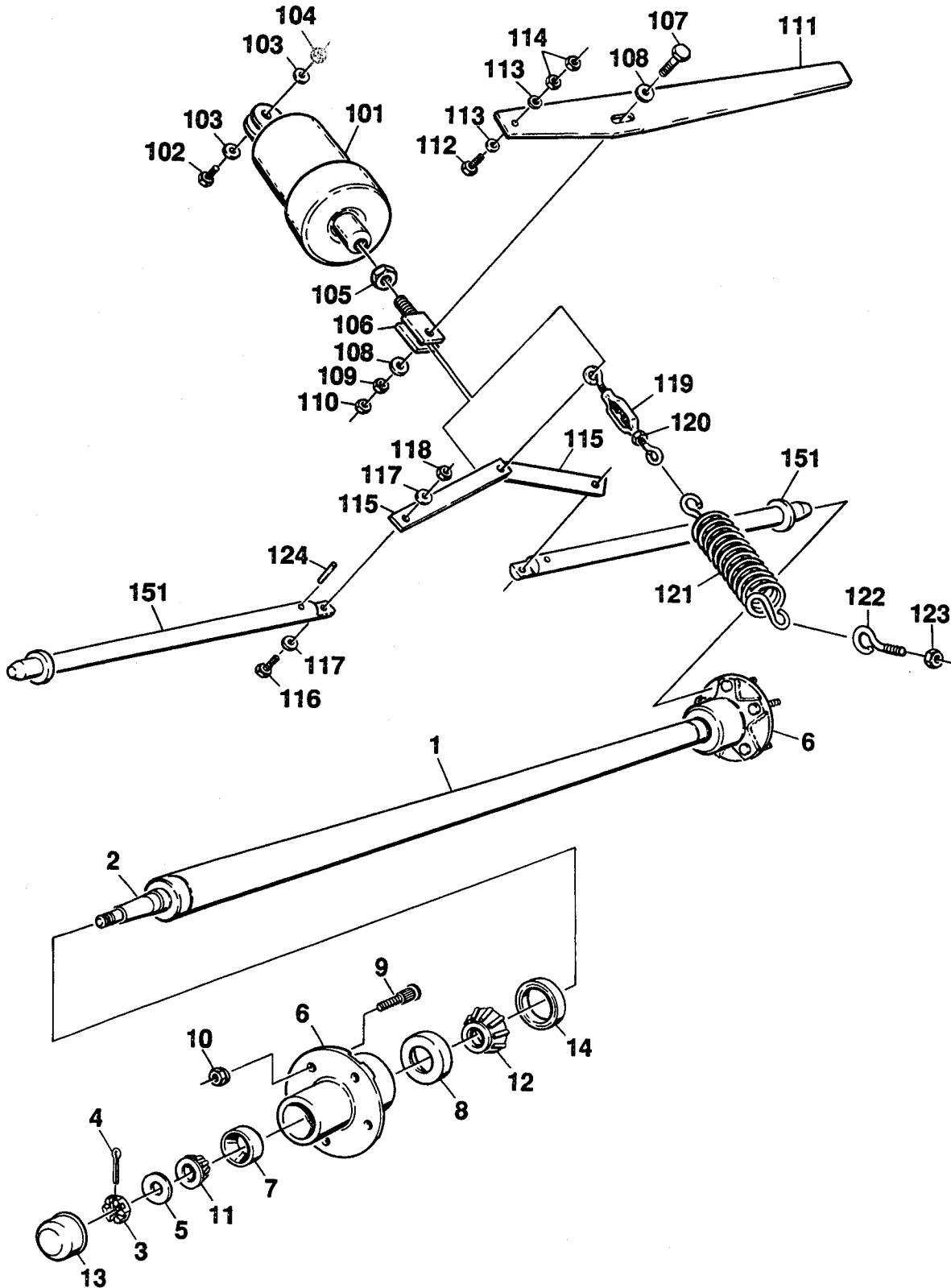
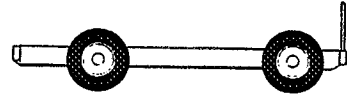

SECTION 11-1 FRAME



SECTION 11-1 FRAME

FIGURE & ITEM NO	PART NUMBER	DESCRIPTION	QTY.	REV.
11-1-3		REAR AXLE AND BRAKE INSTALLATIONS (PRIOR TO MARCH 1992)	Ref.	
	0280120	AXLE ASSEMBLY (CM2033)	Ref.	A
	0280121	AXLE ASSEMBLY (CM2046/CM2546)	Ref.	A
	0280122	AXLE ASSEMBLY (CM2558)	Ref.	A
-1	Not Serviced	Tube, Axle	1	
-2	Not Serviced	Spindle	2	
-3	7010641	Nut, Spindle	2	
-4	7010642	Pin, Cotter	2	
-5	7010643	Washer	2	
-6	7010644	Hub Assembly	2	
-7	Kit	Cup, Bearing (Outer) (1 Per Hub)	2	
-8	Kit	Cup, Bearing (Inner) (1 Per Hub)	2	
-9	7012613	Stud, Wheel 1/2"-20NF	10	
-10	7010645	Lugnut 1/2"-20NF	10	
-11	Kit	Cone, Bearing (Outer)	2	
-12	Kit	Cone, Bearing (Inner)	2	
-13	7010648	Cap, Dust	2	
-14	Kit	Seal, Hub	2	
	2900778	Bearing Kit (Includes Qty. 1 of Items 7,8,11,12 and 14)	2	
		BRAKE INSTALLATIONS (STANDARD PARTS)	Ref.	
-101	1682445	Brake Cylinder Assembly (See Section 11-5 for Breakdown)	1	
-102	0641620	Bolt 3/8"-16NC x 2 1/2"	1	
-103	4751600	Flatwasher 3/8"	2	
-104	3311605	Locknut 3/8"-16NC	1	
-105	3322202	Nut, Jam 3/4"-16NF	1	
-106	1360231	Clevis	1	
-107	0641624	Bolt 3/8"-16NC x 3"	1	
-108	4751600	Flatwasher 3/8"	4	
-109	3311601	Nut 3/8"-16NC	1	
-110	3311602	Nut, Jam 3/8"-16NC	1	
-111	3534818	Lever, Release	1	
-112	0641614	Bolt 3/8"-16NC x 1 3/4"	1	
-113	4751600	Flatwasher 3/8"	2	
-114	3311601	Nut 3/8"-16NC	2	
-115	3010099	Link, Brake	2	
-116	0641612	Bolt 3/8"-16NC x 1 1/2"	1	
-117	4751600	Flatwasher 3/8"	2	
-118	3311605	Locknut 3/8"-16NC	1	
-119	4600004	Turnbuckle	1	
-120	3311401	Nut 1/4"-20NC	1	
-121	4160096	Spring	1	
-122	0630440	Eyebolt (Includes Nut Item 123)	1	
-123	3311401	Nut 1/4"-20NC	1	
-124	3440824	Rollpin	A/R	

SECTION 11-1 FRAME

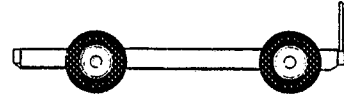

SECTION 11-1 FRAME

FIGURE & ITEM NO	PART NUMBER	DESCRIPTION	QTY.	REV.
11-1-3		REAR AXLE AND BRAKE INSTALLATIONS (PRIOR TO MARCH 1992) (CONTINUED)	Ref.	
	0251118	BRAKE INSTALLATION - MODEL CM2033 (VARIABLE PARTS)	Ref.	E
-151	3841079	Rod, Brake	2	
	0251380	BRAKE INSTALLATION - MODELS CM2046 AND CM2546 (VARIABLE PARTS)	Ref.	E
-151	4843785	Rod, Brake	2	
	0251381	BRAKE INSTALLATION - MODEL CM2558 (VARIABLE PARTS)	Ref.	E
-151	4843786	Rod, Brake	2	

SECTION 11-1 FRAME

FIGURE 11-1-4. REAR AXLE AND BRAKE INSTALLATIONS (MARCH 1992 TO PRESENT).

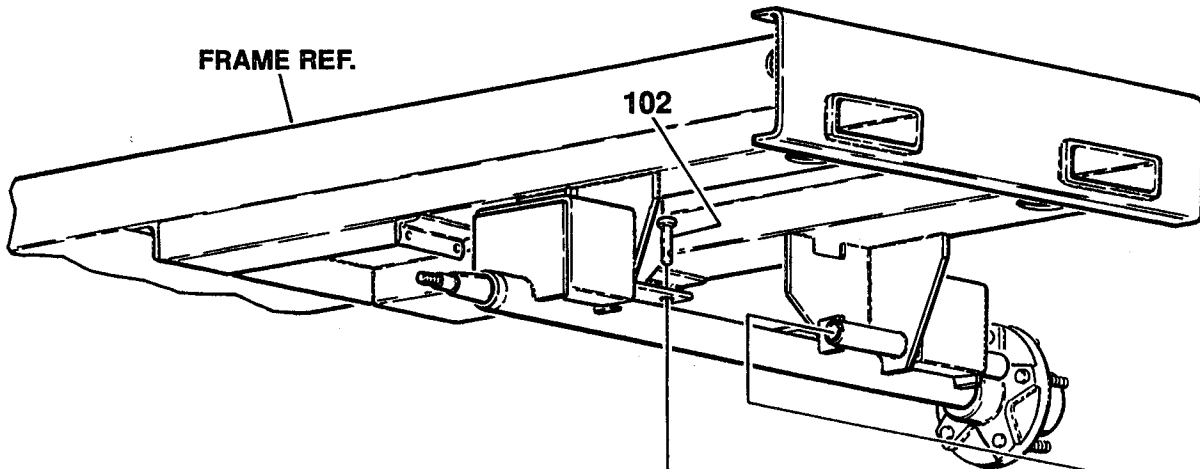
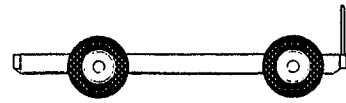

NOTE:
CYLINDER COMPONENTS
TYPICAL BOTH SIDES.

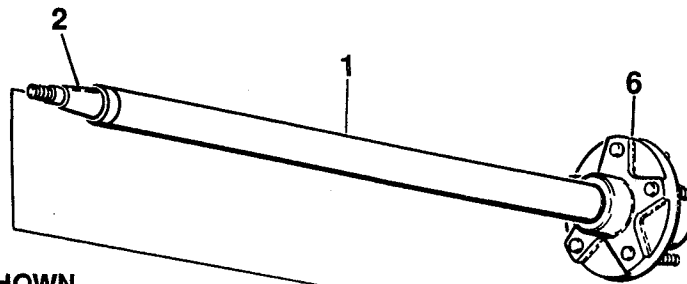

NOTE:
AXLE ASSEMBLY SHOWN
HERE FOR CLARITY.

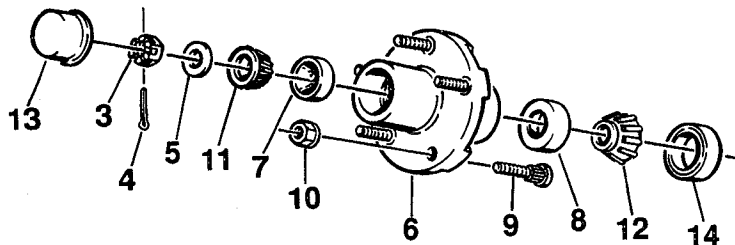

SECTION 11-1 FRAME

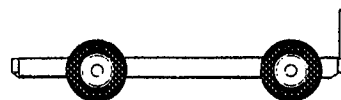

SECTION 11-1 FRAME

FIGURE & ITEM NO	PART NUMBER	DESCRIPTION	QTY.	REV.
11-1-4		REAR AXLE AND BRAKE INSTALLATIONS (MARCH 1992 TO PRESENT)	Ref.	
	0280120	AXLE ASSEMBLY (CM2033)	Ref.	A
	0280121	AXLE ASSEMBLY (CM2046/CM2546)	Ref.	A
	0280122	AXLE ASSEMBLY (CM2558)	Ref.	A
-1	Not Serviced	Tube, Axle	1	
-2	Not Serviced	Spindle	2	
-3	7010641	Nut, Spindle	2	
-4	7010642	Pin, Cotter	2	
-5	7010643	Washer	2	
-6	7010644	Hub Assembly	2	
-7	Kit	Cup, Bearing (Outer) (1 Per Hub)	2	
-8	Kit	Cup, Bearing (Inner) (1 Per Hub)	2	
-9	7012613	Stud, Wheel 1/2"-20NF	10	
-10	7010645	Lugnut 1/2"-20NF	10	
-11	Kit	Cone, Bearing (Outer)	2	
-12	Kit	Cone, Bearing (Inner)	2	
-13	7010648	Cap, Dust	2	
-14	Kit	Seal, Hub	2	
	2900778	Bearing Kit (Includes Qty. 1 of Items 7,8,11,12 and 14)	2	
		BRAKE INSTALLATIONS (STANDARD PARTS)	Ref.	
-101	1683098	Brake Cylinder Assembly (See Section 11-5 for Breakdown)	2	
-102	3430616	Pin, Clevis	2	
-103	4711600	Flatwasher 3/8" Narrow	2	
-104	3450304	Pin, Cotter 3/32" (.2cm) x 1" (2.5cm)	2	
-105	Not Used			
-106	Not Used			
-107	4844188	Cam Weldment	2	
-108	0641624	Bolt 3/8"-16NC x 3"	2	
-109	3311605	Locknut 3/8"-16NC	2	
	0252111	BRAKE INSTALLATION - MODEL CM2033 (VARIABLE PARTS)	Ref.	C
-151	3841129	Rod, Brake	2	
	0252700	BRAKE INSTALLATION - MODELS CM2046 AND CM2546 (VARIABLE PARTS)	Ref.	B
-151	3841169	Rod, Brake	2	
	0252700	BRAKE INSTALLATION - MODEL CM2558 (VARIABLE PARTS)	Ref.	B
-151	3841170	Rod, Brake	2	

SECTION 11-1 FRAME

FIGURE 11-1-5. FRAME MOUNTED COMPONENTS INSTALLATION.

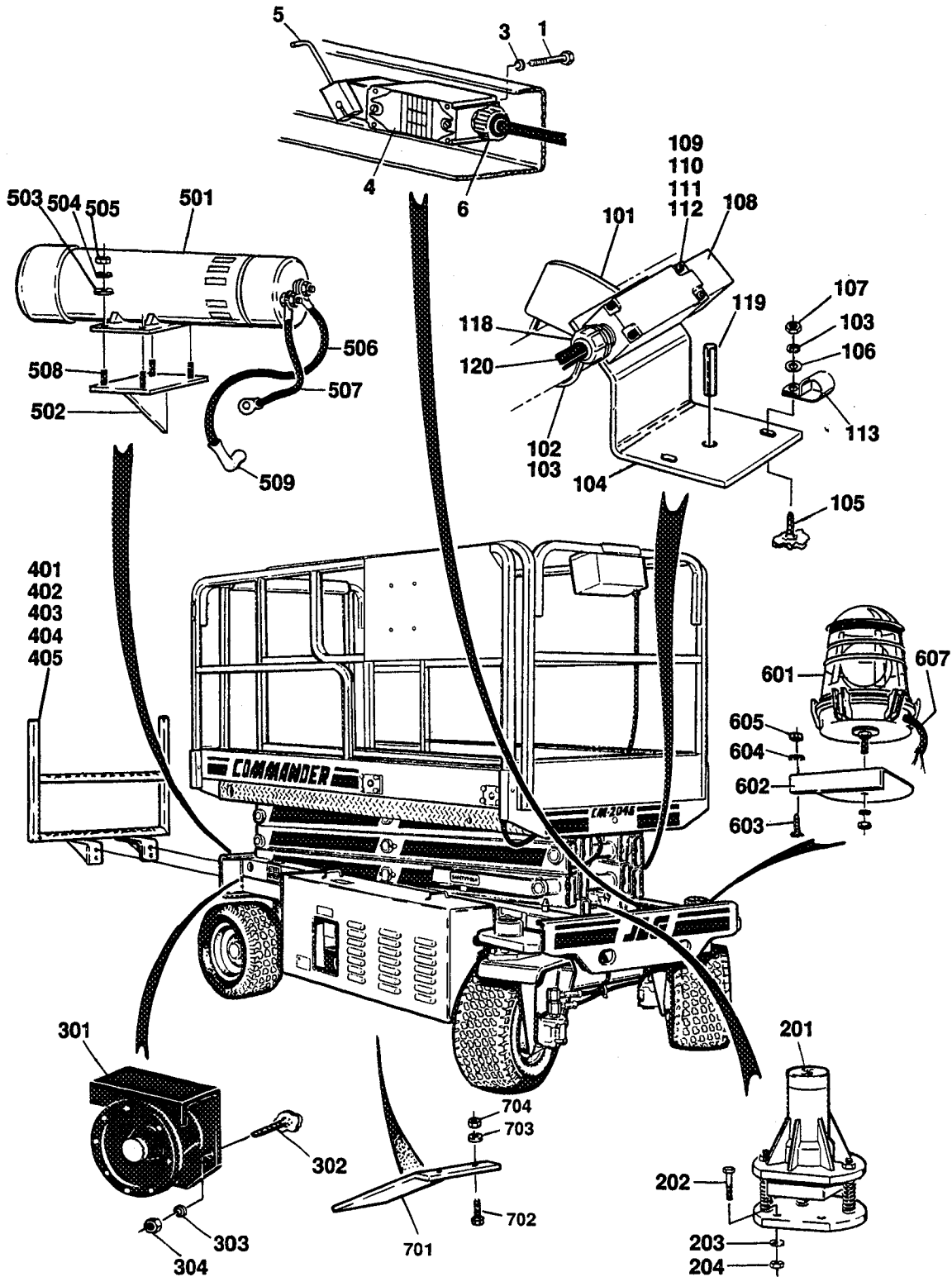
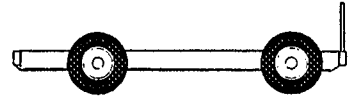

SECTION 11-1 FRAME

SECTION 11-1 FRAME



SECTION 11-1 FRAME

FIGURE & ITEM NO	PART NUMBER	DESCRIPTION	QTY.	REV.
11-1-5		FRAME MOUNTED COMPONENTS INSTALLATION	Ref.	
	0251338	LIMIT SWITCH INSTALLATION - STANDARD	Ref.	
-1	3900158	Screw, Machine #10-32NF x 5/8"	2	
-2	Not Used			
-3	4761000	Lockwasher #10	2	
-4	4360057	Switch, Limit	1	
-5	4360056	Lever, Switch	1	
-6	4460052	Connector, Strain Relief	1	
	0252097	DRIVE CUTOUT SWITCH (PRIOR TO AUGUST 1992)	Ref.	—
	0253491	DRIVE CUTOUT SWITCH (AUGUST 1992 TO PRESENT) Standard on CM2046 and CM2558. Required on CM2033 with Non-Marking Tires. Required on CM2546 with Foam-Filled Tires. Required on Machines with Hydraulic Extendable Deck.	Ref.	A
-101	4843962	Cam Weldment	1	
-102	1320021	Clamp	1	
-103	4761500	Lockwasher 5/16"	4	
-104	0901786	Bracket, Switch Mounting	1	
-105	4300038	Stud (Welded on Part)	2	
-106	4751500	Flatwasher 5/16"	2	
-107	3311501	Nut 5/16"-18NC	2	
-108	4360300	Switch, Limit	1	
-109	3930832	Screw, Machine #8-32NC x 2"	4	
-110	4750800	Flatwasher #8	4	
-111	4760800	Lockwasher #8	4	
-112	3310801	Nut #8-32NC	4	
-113	1320061	Clamp	2	
-114	Not Used			
-115	Not Used			
-116	Not Used			
-117	Not Used			
-118	4460049	Connector, Strain Relief	1	
-119	3440616	Rollpin 3/16" x 1"	2	
-120	1060341	Cable, Electrical - 16/2	15 ft./4.6m	
		TILT INDICATOR INSTALLATION (OPTIONAL) (STANDARD PARTS WHEN EQUIPPED)	Ref.	
-201	4360303	Switch/Harness Assembly	1	
	4360171	Sensor, Level - 5°	1	
	1060300	Cable, Electrical - 16/3	9 ft./2.7m	
-202	0641407	Bolt 1/4"-20NC x 7/8"	2	
-203	4761400	Lockwasher 1/4"	2	
-204	3311401	Nut 1/4"-20NC	2	
	0252311	TILT INDICATOR INSTALLATION (OPTIONAL PARTS WITH UL RATING "EE") (NOT SHOWN)	Ref.	A
	1670547	Cover, Tilt Switch	1	

SECTION 11-1 FRAME

SECTION 11-1 FRAME



FIGURE & ITEM NO	PART NUMBER	DESCRIPTION	QTY.	REV.
11-1-5		FRAME MOUNTED COMPONENTS INSTALLATION (CONTINUED)	Ref.	
	3535594	Plate, End Cover	1	
	2540015	Grommet	1	
	0251762	DESCENT ALARM INSTALLATION	Ref.	B
	0254287	DESCENT ALARM INSTALLATION (U/L)	Ref.	A
	0251761	MOTION ALARM INSTALLATION - TOGGLE SWITCH DRIVE	Ref.	B
	0254285	MOTION ALARM INSTALLATION - TOGGLE SWITCH DRIVE (U/L)	Ref.	B
	0254268	MOTION ALARM INSTALLATION - PQ CONTROLLER DRIVE	Ref.	—
	0254288	MOTION ALARM INSTALLATION - PQ CONTROLLER DRIVE (U/L)	Ref.	—
	0251760	TRAVEL ALARM INSTALLATION - TOGGLE SWITCH DRIVE	Ref.	B
	0254286	TRAVEL ALARM INSTALLATION - TOGGLE SWITCH DRIVE (U/L)	Ref.	A
	0254267	TRAVEL ALARM INSTALLATION - PQ CONTROLLER DRIVE	Ref.	—
	0254289	TRAVEL ALARM INSTALLATION - PQ CONTROLLER DRIVE (U/L)	Ref.	—
—301		Alarm	1	
	0140025	Alarm (No Longer Available - Use 0140033)		
	0140033	Alarm (August 1993 to Present)		
—302	4300038	Stud (Welded on Part)	2	
—303	4761500	Lockwasher 5/16"	2	
—304	3311501	Nut 5/16"-18NC	2	
		LADDER INSTALLATION (OPTIONAL) (STANDARD PARTS WHEN EQUIPPED)	Ref.	
—401	Not Used			
—402	0641610	Bolt 3/8"-16NC x 1 1/4"	4	
—403	4761600	Lockwasher 3/8"	4	
—404	4751600	Flatwasher 3/8"	4	
—405	3311601	Nut 3/8"-16NC	4	
	0252853	LADDER INSTALLATION - WITHOUT GRAB RAILS (OPTIONAL) (VARIABLE PARTS)	Ref.	A
—451	4844049	Ladder Weldment	1	
	3520071	Cap, Plastic	2	
	0233546	LADDER INSTALLATION - WITH GRAB RAILS (OPTIONAL) (VARIABLE PARTS)	Ref.	—
—451	4844326	Ladder Weldment	1	—
	3520071	Cap, Plastic	2	
	4565995	Tube, Grab Rail (Welded to Rear of Handrails - Not Shown)	2	

SECTION 11-1 FRAME

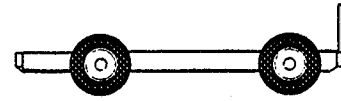

SECTION 11-1 FRAME

FIGURE & ITEM NO	PART NUMBER	DESCRIPTION	QTY.	REV.
11-1-5		FRAME MOUNTED COMPONENTS INSTALLATION (CONTINUED)	Ref.	
	0250464	110V GENERATOR INSTALLATION (OPTIONAL)	Ref.	B
-501	2460022	Generator	1	
-502	4843509	Bracket, Generator Mounting	1	
-503	4751500	Flatwasher 5/16"	5	
-504	4761500	Lockwasher 5/16"	5	
-505	3311501	Nut 5/16"-18NC	5	
-506	1060560	Cable	1	
-507	1060045	Cable	1	
-508	4300038	Stud (Welded on Part)	1	
-509	0840027	Boot, Terminal	1	
	0252274	BEACON LIGHT INSTALLATION	Ref.	A
-601	2920087	Light, Beacon	1	
-602	0901546	Bracket, Mounted	1	
-603	4300041	Stud (Welded on Part)	2	
-604	4761400	Lockwasher 1/4"	2	
-605	3311401	Nut 1/4"-20NC	2	
-606	Not Used			
-607	1060341	Cable, Electrical - 16/2	6 ft./1.8m	
	0254128	TRAY COVER INSTALLATION	Ref.	—
-701	4060856	Cover	1	
-702	0641407	Bolt 1/4"-20NC x 7/8"	2	
-703	4751400	Flatwasher 1/4"	4	
-704	3311405	Locknut 1/4"-20NC	2	

SECTION 11-2 GROUND COMPONENTS

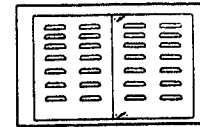

TABLE OF CONTENTS

FIGURE NO.	TITLE	PAGE NO.
11-2-1	Covers, Controls, Tank and Valves Installation	11-2-2
11-2-2	Control Valve Assembly - Hydro-Air (Machines with Bang-Bang Drive Built Prior to June 1992)	11-2-8
11-2-3	Control Valve Assembly - Hydro-Air (Machines With Bang-Bang Drive Built June 1992 to Present)	11-2-12
11-2-4	Control Valve Assembly - Hydro Air (Machines With Proportional Drive)	11-2-16
11-2-5	Control Valve Assembly - Hydro Air (Hydraulically Extended Deck Options)	11-2-20
11-2-6	Batteries and Chargers Installation	11-2-22
11-2-7	Battery Charger Assembly	11-2-26
11-2-8	UL Listed Components Installation - Ground Components	11-2-28

SECTION 11 - 2 GROUND COMPONENTS

SECTION 11-2 GROUND COMPONENTS

FIGURE 11-2-1. COVERS, CONTROLS, TANK AND VALVES INSTALLATION.

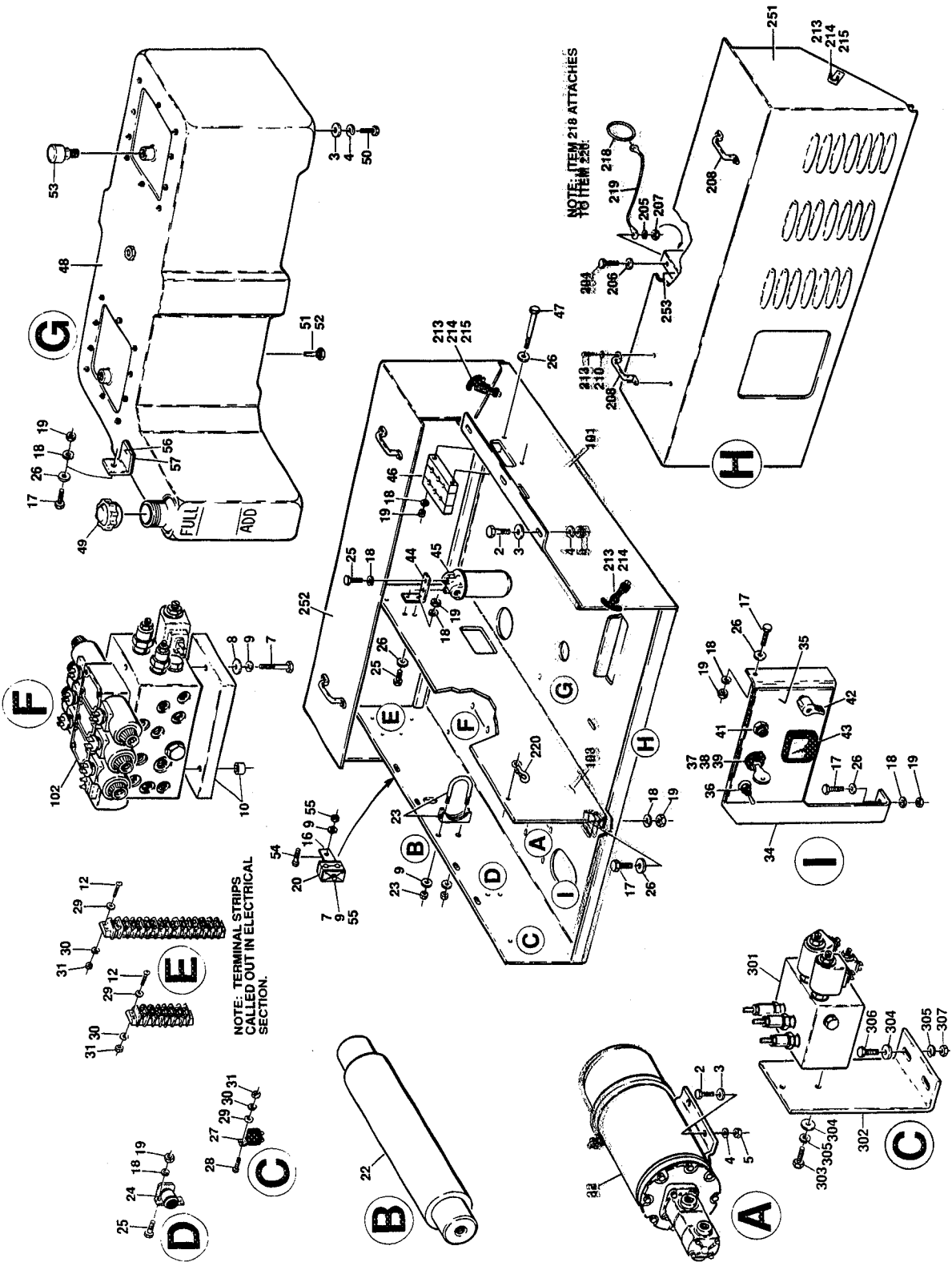
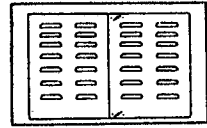

S-11Z0P2M0C DZC0R2 N-11 Z0-H0M0S

SECTION 11-2 GROUND COMPONENTS

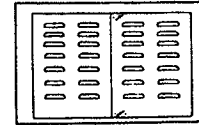

SECTION 11-2 GROUND COMPONENTS

FIGURE & ITEM NO	PART NUMBER	DESCRIPTION	QTY.	REV.
11-2-1		COVERS, CONTROLS, TANK AND VALVES INSTALLATION	Ref.	
		GROUND CONTROLS, TANKS AND VALVES INSTALLATION	Ref.	
—1	Not Used			
—2	0641609	Bolt 3/8"-16NC x 1 1/8"	A/R	
—3	4751600	Flatwasher 3/8"	A/R	
—4	4761600	Lockwasher 3/8"	A/R	
—5	3311601	Nut 3/8"-16NC	A/R	
—6	Not Used			
—7	0641516	Bolt 5/16"-18NC x 2"	4	
—8	4751500	Flatwasher 5/16"	4	
—9	4761500	Lockwasher 5/16"	8	
—10		Spacer Options:	A/R	
	3534699	Plate (Machines Built Prior to September 1991)	1	
	0961378	Bushing (Machines Built September 1991 to Present)	3	
—11	Not Used			
—12	3911016	Screw, Machine #10-24NC x 1"	2	
—13	Not Used			
—14	Not Used			
—15	Not Used			
—16	0181593	Angle, Mounting	1	
—17	0641407	Bolt 1/4"-20NC x 7/8"	5	
—18	4761400	Lockwasher 1/4"	A/R	
—19	3311401	Nut 1/4"-20NC	A/R	
—20	1320159	Clamp, Hose	1	
—21	Not Used			
—22	1682664	Cylinder, Cushion (Bang-Bang Drive Units Only)	1	
		Note: Machines built prior to March 1992 require larger size clamp P/N 1320185 for installation.		
	3480163	Piston	1	
	2901209	Seal Kit	1	
	2180699	Fitting, 90°	2	
	2180422	Fitting	2	
—23	1320185	Clamp, Muffler	1	
—24	3740068	Relay - 200 Amp/24VDC	1	
—25	0641406	Bolt 1/4"-20NC x 3/4"	7	
—26	4751400	Flatwasher 1/4"	A/R	
—27	3740069	Relay (When Equipped)	1	
—28	3911012	Screw, Machine #10-24NC x 3/4"	1	
—29	4751000	Flatwasher #10	3	
—30	4761000	Lockwasher #10	3	
—31	3311001	Nut #10-24NC	3	
—32		Pump/Motor Assembly - Flex Drive		
	3600184	Barnes Pump/Prestolite Motor Assembly - Tang Drive (Machines Built Prior to June 1990)	1	
		Note: When replacing complete pump/motor assembly use 3600184.		
		Prestolite Motor Assembly (Purchase 7010924 as Replacement)	1	
	7012565	Brush Kit for 7004338 Motor (Brushes Only)	1	
	7004336	Barnes Pump Assembly	1	

SECTION 11-2 GROUND COMPONENTS

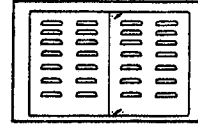

SECTION 11-2 GROUND COMPONENTS

FIGURE & ITEM NO	PART NUMBER	DESCRIPTION	QTY.	REV.
11-2-1		COVERS, CONTROLS, TANK AND VALVES INSTALLATION (CONTINUED)	Ref.	
	7004337	Drive Shaft	1	
	3600148	Barnes Pump/Ohio Motor Assembly - Tang Drive (Machines Built June 1990 to August 1991) Note: When replacing complete pump/motor assembly use 3600184.	1	
	7010924	Ohio Motor Assembly	1	
	7010639	Brush for 7010924 Motor	2	
	7010640	Spring for 7010924 Motor	8	
	7010952	Barnes Pump Assembly	1	
	3600184	Barnes Pump/Ohio Motor Assembly - Flex Drive (Machines built August 1991 to Present)	1	
	7010943	Ohio Motor Assembly	1	
	7010639	Brush for 7010943 Motor	2	
	7010640	Spring for 7010943 Motor	8	
	7010951	Barnes Pump Assembly	1	
	7010944	Coupling, Flex	1	
-33	Not Used			
-34	3534561	Plate, Ground Control	1	
-35	3252054	Nameplate - Ground Control (Prior to September 1992)	1	
	3252091	Nameplate - Ground Control (September 1992 to Present)	1	
-36	4360202	Switch, Toggle	1	
-37	4360290	Switch, Keyed	1	
	7010698	Key Replacement	1 set	
-38	4360267	Block, Contact	1	
-39	4360281	Block, Contact	1	
-40	Not Used			
-41	4360070	Breaker, Circuit	1	
-42	4360155	Switch, Master	1	
-43	2420116	Ammeter	1	
-44	0901728	Bracket, Filter Mounting	1	
-45	2120105	Filter, Return	1	
	2120072	Element - 20 Micron (Standard)	1	
	2120148	Element - 10 Micron (Optional)	1	
-46	1320178	Clamp, Tube	1	
-47	0641432	Bolt 1/4"-20NC x 4"	2	
-48	4400324	Tank, Hydraulic (Includes Item 49)	1	
-49	1120361	Cap, Tank	1	
-50	0641608	Bolt 3/8"-16NC x 1"	2	
-51	3520076	Plug, Magnetic	1	
-52	0100020	Sealant, Pipe	A/R	
-53	1340052	Breather	1	
-54	0641508	Bolt 5/16"-18NC x 1"	2	
-55	3311501	Nut 5/16"-18NC	3	
-56	0181636	Angle, Mounting	1	
-57	4420038	Tape, Insulation	2 in./5cm	
-58	0100048	Compound, Silicone (Not Shown)	A/R	

SECTION 11-2 GROUND COMPONENTS

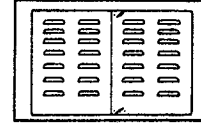

SECTION 11 - 2 GROUND COMPONENTS

FIGURE & ITEM NO	PART NUMBER	DESCRIPTION	QTY.	REV.
11-2-1		COVERS, CONTROLS, TANK AND VALVES INSTALLATION (CONTINUED)	Ref.	
	0251320	GROUND CONTROLS, TANK AND VALVES INSTALLATION - CM2033 WITH BANG-BANG DRIVE (VARIABLE PARTS)	Ref.	O
-101	3534467	Hydraulic Tray Options: Tray, Hydraulic (Prior to January 1994)	1	
	3537285	Tray, Hydraulic (January 1994 to Present)		
-102	4640657	Control Valve Assembly - Machines built prior to June 1992 (See Figure 11-2-2 for Breakdown)	1	
	4640733	Control Valve Assembly - Machines June 1992 to Present (See Figure 11-2-3 for Breakdown)	1	
-103	3534649	Plate, Divider	1	
	0252426	GROUND CONTROLS, TANK AND VALVES INSTALLATION - CM2033 WITH PROPORTIONAL DRIVE (VARIABLE PARTS)	Ref.	D
-101	3534467	Hydraulic Tray Options: Tray, Hydraulic (Prior to January 1994)	1	
	3537285	Tray, Hydraulic (January 1994 to Present)		
-102	0252689	Control Valve Assembly (See Figure 11-2-4 for Breakdown)	1	
-103	3534649	Plate, Divider	1	
	0251371	GROUND CONTROLS, TANK AND VALVES INSTALLATION - CM2046 WITH BANG-BANG DRIVE (VARIABLE PARTS)	Ref.	P
-101	3534650	Hydraulic Tray Options: Tray, Hydraulic (Prior to January 1994)	1	
	3537284	Tray, Hydraulic (January 1994 to Present)		
-102	4640657	Control Valve Assembly - Machines built prior to June 1992 (See Figure 11-2-2 for Breakdown)	1	
	4640733	Control Valve Assembly - Machines built June 1992 to Present (See Figure 11-2-3 for Breakdown)	1	
-103	3534651	Plate, Divider	1	
	0252422	GROUND CONTROLS, TANK AND VALVES INSTALLATION - CM2046 WITH PROPORTIONAL DRIVE (VARIABLE PARTS)	Ref.	C
-101	3534650	Hydraulic Tray Options: Tray, Hydraulic (Prior to January 1994)	1	
	3537284	Tray, Hydraulic (January 1994 to Present)		
-102	0252689	Control Valve Assembly (See Figure 11-2-4 for Breakdown)	1	
-103	3534651	Plate, Divider	1	

SECTION 11-2 GROUND COMPONENTS

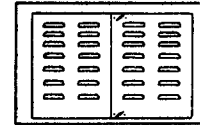

SECTION 11-2 GROUND COMPONENTS

FIGURE & ITEM NO	PART NUMBER	DESCRIPTION	QTY.	REV.
11-2-1		COVERS, CONTROLS, TANK AND VALVE INSTALLATION (CONTINUED)	Ref.	
	0251500	GROUND CONTROLS, TANK AND VALVE INSTALLATION CM2546 AND CM2558 WITH BANG-BANG DRIVE (VARIABLE PARTS)	Ref.	L
-101	4843805	Tray, Hydraulic	1	
-102	4640657	Control Valve Assembly - Machines built prior to June 1992 (See Figure 11-2-2 for Breakdown)	1	
	4640733	Control Valve Assembly - Machines built June 1992 to Present (See Figure 11-2-3 for Breakdown)		
-103	3534651	Plate, Divider	1	
	0252423	GROUND CONTROLS, TANK AND VALVES INSTALLATION - CM2546 AND CM2558 WITH PROPORTIONAL DRIVE (VARIABLE PARTS)	Ref.	B
-101	4843805	Tray, Hydraulic	1	
-102	0252689	Control Valve Assembly (See Figure 11-2-4 for Breakdown)	1	
-103	3534651	Plate, Divider	1	
		COVERS INSTALLATION (STANDARD PARTS)	Ref.	
-201	Not Used			
-202	Not Used			
-203	Not Used			
-204	0641406	Bolt 1/4"-20NC x 3/4"	4	
-205	4761400	Lockwasher 1/4"	4	
-206	4751400	Flatwasher 1/4"	4	
-207	3311401	Nut 1/4"-20NC	4	
-208	2560003	Handle	4	
-209	Not Used			
-210	4751000	Flatwasher #10	8	
-211	Not Used			
-212	Not Used			
-213	3820020	Rivet 3/16"	16	
-214	2940062	Latch, Rubber	4	
-215	3820019	Rivet - 31/16"	8	
-216	Not Used			
-217	Not Used			
-218	3760170	Ring	2	
-219	1060379	Cable, Lanyard	2	
-220	2940065	Latch, Snap	2	

SECTION 11-2 GROUND COMPONENTS

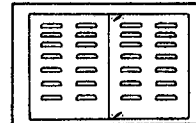

SECTION 11-2 GROUND COMPONENTS

FIGURE & ITEM NO	PART NUMBER	DESCRIPTION	QTY.	REV.
11-2-1		COVERS, CONTROLS, TANK AND VALVES INSTALLATION (CONTINUED)	Ref.	
	0251212	COVERS INSTALLATION - CM2033 (NOT SHOWN) (VARIABLE PARTS)	Ref.	B
—251	4060762	Cover (RH)	1	
—252	4060763	Cover (LH)	1	
—253	4060764	Support, Shield	2	
	0251390	COVERS INSTALLATION - CM2046, CM2546 AND CM2558 (VARIABLE PARTS)	Ref.	B
—251	4060771	Cover (RH)	1	
—252	4060772	Cover (LH)	1	
—253	4060773	Support, Shield	2	
	0254811	VALVE INSTALLATION - HYDRAULICALLY EXTENDED DECK OPTION	Ref.	—
—301	4640870	Valve Assembly (Section Figure 11-2-5 for Breakdown)	1	
—302	0902053	Bracket	1	
—303	0641506	Bolt 5/16"-18NC x 3/4"	2	
—304	4751500	Flatwasher 5/16"	6	
—305	4761500	Lockwasher 5/16"	4	
—306	0641508	Bolt 5/16"-18NC x 1"	2	
—307	3311505	Locknut 5/16"-18NC	2	

SECTION 11-2 GROUND COMPONENTS

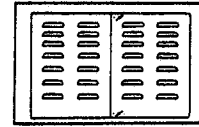
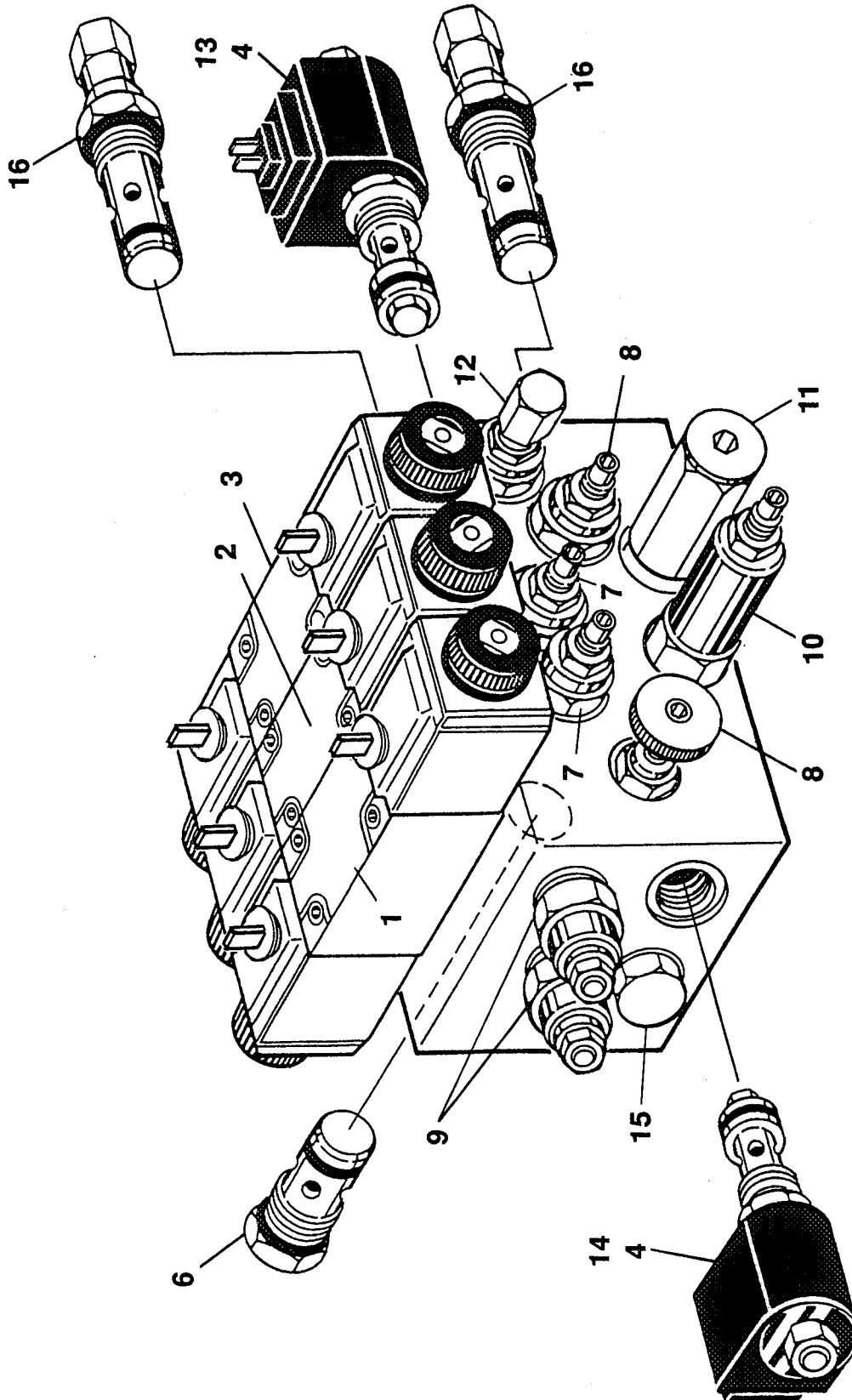
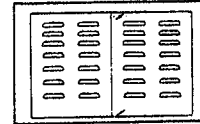

FIGURE 11-2-2. CONTROL VALVE ASSEMBLY - HYDRO-AIR
(MACHINES WITH BANG-BANG DRIVE BUILT PRIOR TO JUNE 1992).



SECTION 11-2 GROUND COMPONENTS

SECTION 11-2 GROUND COMPONENTS CM2033/CM2046/CM2546/CM2558



SECTION 11-2 GROUND COMPONENTS

FIGURE & ITEM NO	PART NUMBER	DESCRIPTION	QTY.	REV.
11-2-2	4640657	CONTROL VALVE ASSEMBLY - HYDRO-AIR (MACHINES WITH BANG-BANG DRIVE BUILT PRIOR TO JUNE 1992)	Ref.	A
		NOTE: IDENTIFY BY P/N STAMPED ON THE FOLLOWING COMPONENTS BEFORE ORDERING REPLACEMENT PARTS. SHAPE OF COMPONENTS MAY VARY.		
-1	4640737	Rexroth Directional Valve Assembly (Drive)	1	
	7012726	Coil (Rexroth)	2	
	7012725	Seal Kit (Rexroth)	1	
	Not Available	Vickers Directional Valve Assembly (Drive) (No Longer Available Replace with P/N 4640737)	1	
	7010534	Coil (Vickers)	2	
-2	4640737	Rexroth Directional Valve Assembly (Lift/Hi-Drive)	1	
	7012726	Coil (Rexroth)	2	
	7012725	Seal Kit (Rexroth)	1	
	Not Available	Vickers Directional Valve Assembly (Lift/Hi-Drive) (No Longer Available. Replace with P/N 4640737)	1	
	7010534	Coil (Vickers)	2	
-3	4640740	Rexroth Directional Valve Assembly (Steer)	1	
	7012727	Coil (Rexroth)	2	
	7012725	Seal Kit (Rexroth)	1	
	Not Available	Vickers Directional Valve Assembly (Steer) (No Longer Available. Replace with P/N 4640740)	1	
	7010534	Coil (Vickers)	2	
-4	7012900	Coil - 20 Volt (Hydraforce)	2	
	7004370	Coil - 18 Volt (Vickers/Modular Controls)	2	
-5	Not Used			
-6	7010561	Valve, Check (Vickers/Modular Controls CV1-10-B-05)	1	
	2900503	Seal Kit (Vickers/Modular Controls CV1-10-B-05)	1	
	7012930	Valve, Check (Hydraforce CV10-20-0-N-5)	1	
	2900756	Seal Kit (Hydraforce CV10-20-0-N-5)	1	
-7	7010565	Valve, Flow Control (Vickers/Modular Controls FCV6-10-S-0-FF) (Brake Speed and Lift/Lower Speed Adjustments)	2	
	2900503	Seal Kit (Vickers/Modular Controls FCV6-10-S-0-FF) (1 Per Cartridge)	2	
	7010544	Valve, Flow Control (Hydraforce FC10-20A-0-N) (Brake Speed and Lift/Lower Speed Adjustments)	2	
	7012901	Seal Kit (Hydraforce FC10-20A-0-N) (1 Per Cartridge)	2	
-8	7010567	Valve, Needle (Vickers/Modular Controls FCV6-10-S-0-NV) (Tow and Creep Adjustments)	2	
	2900502	Seal Kit (Vickers/Modular Controls FCV6-10-S-0-NV) (1 Per Cartridge)	2	
	7012933	Valve, Needle (Hydraforce NV10-20A-0-N) (Tow and Creep Adjustments)	2	
	7012901	Seal Kit (Hydraforce NV10-20A-0-N) (1 Per Cartridge)	2	

SECTION 11-2 GROUND COMPONENTS

CM2033/CM2046/CM2546/CM2558

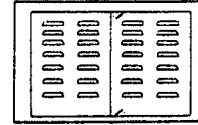

SECTION 11-2 GROUND COMPONENTS

FIGURE & ITEM NO	PART NUMBER	DESCRIPTION	QTY.	REV.
11-2-2	4640657	CONTROL VALVE ASSEMBLY - HYDRO-AIR (MACHINES WITH BANG-BANG DRIVE BUILT PRIOR TO JUNE 1992)	Ref.	A
-9	7004361	Valve, Load Control (Drive Motion Adjustments)	2	
	2900706	Seal Kit (1 Per Cartridge)	2	
-10	7010564	Valve, Sequence (Vickers/Modular Controls PSV2-10-S-0-12) (Hi-Drive Kickout Adjustment) (Cartridge must be adjusted to 1100 PSI when installed)	1	
	2900698	Seal Kit (Vickers/Modular Controls PSV2-10-S-0-12)	1	
	7012934	Valve Sequence (Hydraforce PS10-32A-0-N-15/11) (Hi-Drive Kickout Adjustment)	1	
	2900707	Seal Kit (Hydraforce PS10-32A-0-N-15/11)	1	
-11	4640642	Valve, Relief (Vickers/Modular Controls RV1-10-I-0-36/26) (P1 Relief Pressure Adjustment)	1	
	2900503	Seal Kit (Vickers/Modular Controls RV1-10-I-0-36/26)	1	
	7012932	Valve, Relief (Hydraforce RV10-20H-0-N-33/27) (Pin (P1 Relief Pressure Adjustment)	1	
	2900708	Seal Kit (Hydraforce RV10-20H-0-N-33/27)	1	
-12	7010562	Valve, Relief (Vickers/Modular Controls RV6-10-C-0-25) (P2 Relief Pressure Adjustment) (Cartridge must be adjusted to 2700 PSI when installed)	1	
	2900503	Seal Kit (Vickers/Modular Controls RV6-10-C-0-25)	1	
	7012932	Valve, Relief (Hydraforce RV10-20H-0-N-33/27) (P2 Relief Pressure Adjustment)	1	
	2900708	Seal Kit (Hydraforce RV10-20H-0-N-33/27)	1	
-13	7010536	Valve, Solenoid - Less Coil (Mid-Drive) (Vickers/Modular Controls SV3-10-4-0-00) (Order Coil separately - Manufacturer of the cartridge and the coil must be the same)	1	
	2900696	Seal Kit (Vickers/Modular Controls SV3-10-4-0-00)	1	
	7012920	Valve, Solenoid - Less Coil (Mid-Drive) (Hydraforce SV10-25-0-N-00) (Order Coil separately - Manufacturer of the cartridge and coil must be the same)	1	
	2900708	Seal Kit (Hydraforce SV10-25-0-N-00 and SV10-25-0-N-20DS)	1	
-14	7009744	Valve, Solenoid - Less Coil (Positive Traction) (Vickers/Modular Controls SV4-10-0-00) (Order Coil separately - Manufacturer of the cartridge and the coil must be the same)	1	
	2900502	Seal Kit (Vickers/Modular Controls SV4-10-0-0-00)	1	
	7012919	Valve, Solenoid - Less Coil (Positive Traction) (Hydraforce SV10-42-0-N-00) (Order Coil separately - manufacturer of the cartridge and coil must be the same)	1	
	7012903	Seal Kit (Hydraforce SV10-42-0-N-20DS and SV10-42-0-N-00)	1	

**SECTION 11-2 GROUND COMPONENTS
CM2033/CM2046/CM2546/CM2558**

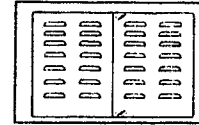

SECTION 11-2 GROUND COMPONENTS

FIGURE & ITEM NO	PART NUMBER	DESCRIPTION	QTY.	REV.
11-2-2	4640657	CONTROL VALVE ASSEMBLY - HYDRO-AIR (MACHINES WITH BANG-BANG DRIVE BUILT PRIOR TO JUNE 1992) (CONTINUED)	Ref.	A
-15	7010503	Valve, Flow Divider (Vickers/Modular Controls FDC1-10-0-44)	1	
	2900696	Seal Kit (Vickers/Modular Controls FDC1-10-0-44)	1	
	7012929	Valve, Flow Divider (Hydraforce FD10-40-0-N-44)	1	
-16	7012904	Seal Kit (Hydraforce FD10-40-0-N-44)		
	7010562	Valve, Relief (Vickers/Modular Controls RV6-10-C-025) (Steer Relief Adjustments) (Cartridge must be adjusted 1500 PSI when installed.)	2	
	2900503	Seal Kit (Vickers/Modular Controls RV6-10-0-25) (1 Per Cartridge)	2	
	7012931	Valve, Relief (Hydraforce RV10-20H-0-N-33/15 and RV10-26H-0-N-30/15) (Steer Relief Adjustments)	2	
	2900708	Seal Kit (Hydraforce RV10-20H-0-N-33/15 and RV10-26H-0-N-30/15) (1 PerCartridge)	2	

SECTION 11-2 GROUND COMPONENTS

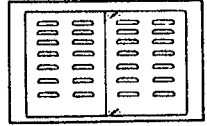
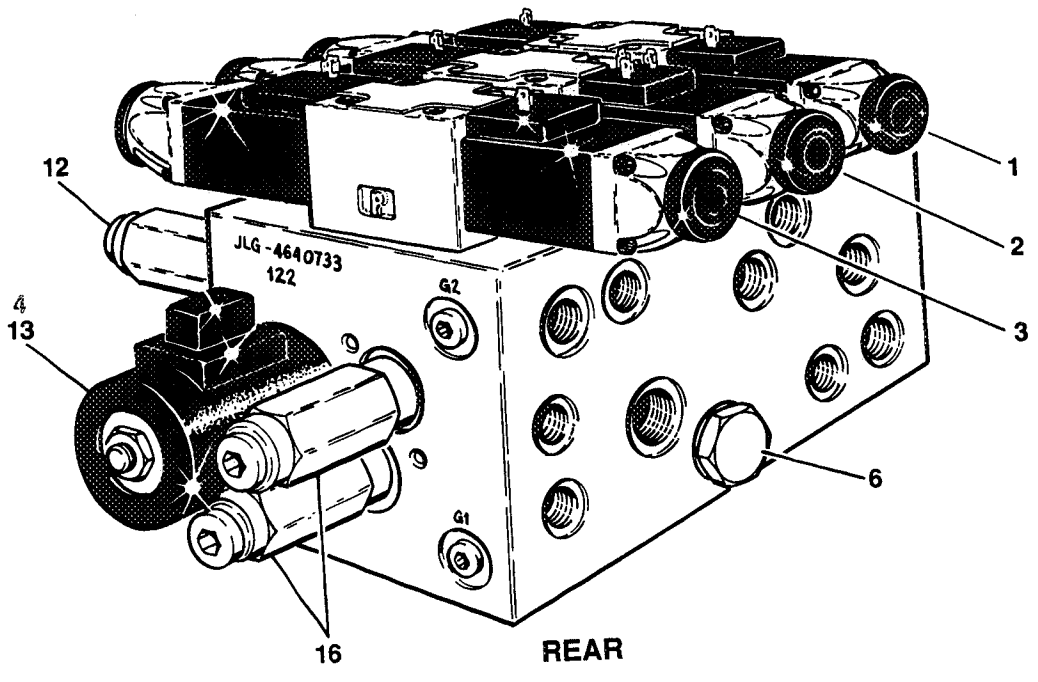
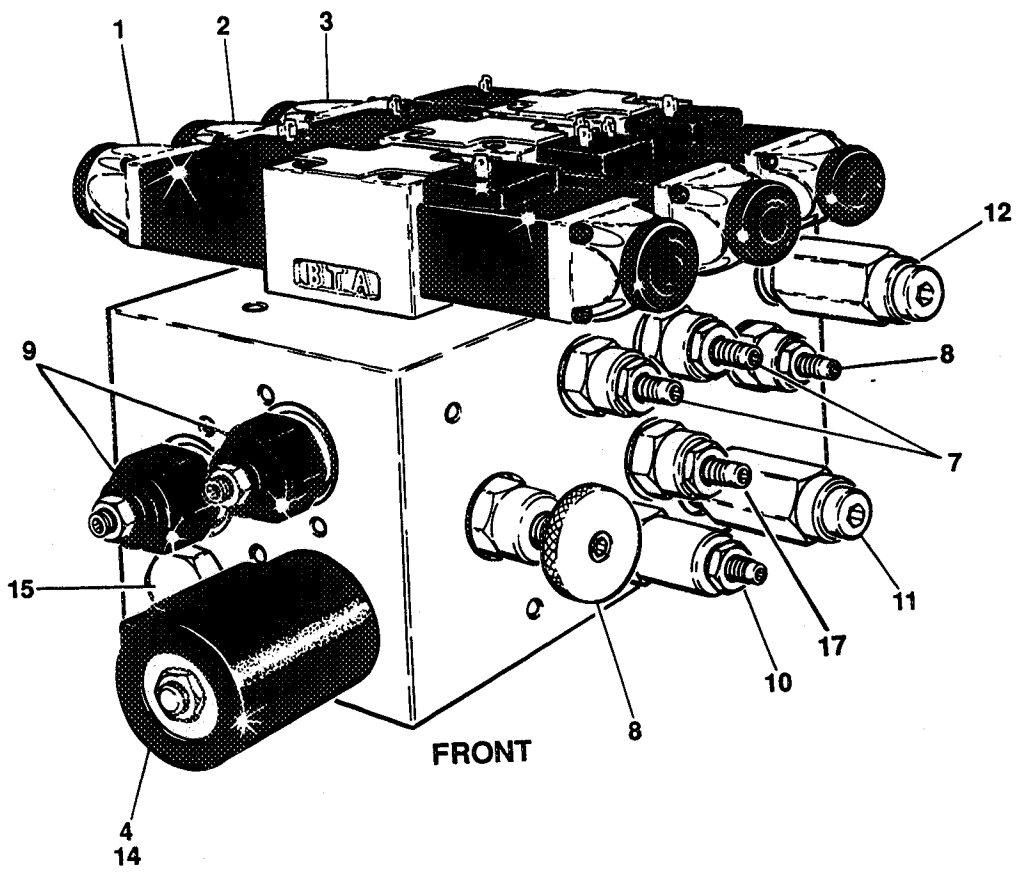
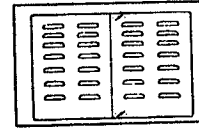

FIGURE 11-2-3. CONTROL VALVE ASSEMBLY - HYDRO-AIR
(MACHINES WITH BANG-BANG DRIVE BUILT JUNE 1992 TO PRESENT).



SECTION 11-2 GROUND COMPONENTS



SECTION 11-2 GROUND COMPONENTS

FIGURE & ITEM NO	PART NUMBER	DESCRIPTION	QTY.	REV.
11-2-3	4640733	CONTROL VALVE ASSEMBLY - HYDRO-AIR (MACHINES WITH BANG-BANG DRIVE BUILT JUNE 1992 TO PRESENT)	Ref.	D
-1	4640737	Rexroth Directional Valve Assembly (Drive)	1	
	7012726	Coil (Rexroth)	2	
	7012725	Seal Kit (Rexroth)	1	
-2	4640745	Rexroth Directional Valve Assembly (Lift/Hi-Drive)	1	
	7012726	Coil - 1 Prong (Rexroth)	1	
	7012732	Coil - 3 Prong (Rexroth)	1	
	7012725	Seal Kit (Rexroth)	1	
-3	4640740	Rexroth Directional Valve Assembly (Steer)	1	
	7012727	Coil (Rexroth)	2	
	7012725	Seal Kit (Rexroth)	1	
-4	7012900	Coil - 20 Volt (Hydraforce)	2	
-5	Not Used			
-6	7012930	Valve, Check	1	
	2900756	Seal Kit (Hydraforce CV10-20-0-N-5)	1	
-7	7010544	Valve, Flow Control (Brake Speed and Lift/Lower Speed Adjustments)	2	
	7012901	Seal Kit (Hydraforce FC10-20A-0-N) (1 Per Cartridge)	2	
-8	7012933	Valve, Needle (Tow and Creep Adjustments)	2	
	7012901	Seal Kit (Hydraforce NV10-20A-0-N) (1 Per Cartridge)	2	
-9	7004361	Valve, Load Control (Drive Motion Adjustments)	2	
	2900706	Seal Kit (1 Per Cartridge)	2	
-10	7012934	Valve, Sequence (Hi-Drive Kickout Adjustment)	1	
	2900707	Seal Kit (Hydraforce PS10-32A-0-N-15/11)	1	
-11	7012932	Valve, Relief (P1 Relief Pressure Adjustment) (Hydraforce Version)	1	
	2900708	Seal Kit (Hydraforce RV10-20H-0-N-33/27)	1	
-12	7012932	Valve, Relief (P2 Relief Pressure Adjustment)	1	
	2900708	Seal Kit (Hydraforce RV10-20H-0-N-33/27)	1	
-13	7012920	Valve, Solenoid - Less Coil (Mid-Drive) (Hydraforce SV10-25-0-N-00) (Order Coil Separately)	1	
	2900708	Seal Kit	1	
-14	7012919	Valve, Solenoid - Less Coil (Positive Traction) (Hydraforce SV10-42-0-N-00) (Order Coil Separately)	1	
	7012903	Seal Kit	1	

SECTION 11-2 GROUND COMPONENTS

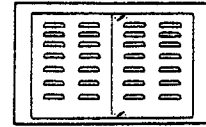

FIGURE & ITEM NO	PART NUMBER	DESCRIPTION	QTY.	REV.
11-2-3	4640733	CONTROL VALVE ASSEMBLY - HYDRO-AIR (MACHINES WITH BANG-BANG DRIVE BUILT JUNE 1992 TO PRESENT) (CONTINUED)	Ref.	D
-15	7012929	Valve, Flow Divider	1	
	7012904	Seal Kit (Hydraforce FD10-40-0-N-44)		
-16	7012931	Valve, Relief (Steer Relief Adjustments)	2	
	2900708	Seal Kit (Hydraforce RV10-26H-N-30/15 and RV10-20H-N-33/15)(1 Per Cartridge)	2	
-17	7012912	Valve, Relief (Lift Relief Pressure) (Machines Built after June 1993 Only)	1	
	7010541	Seal Kit (Hydraforce RV08-20A-0-N-33)	1	

SECTION 11-2 GROUND COMPONENTS

SECTION 11-2 GROUND COMPONENTS

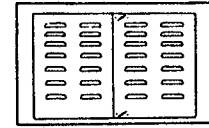
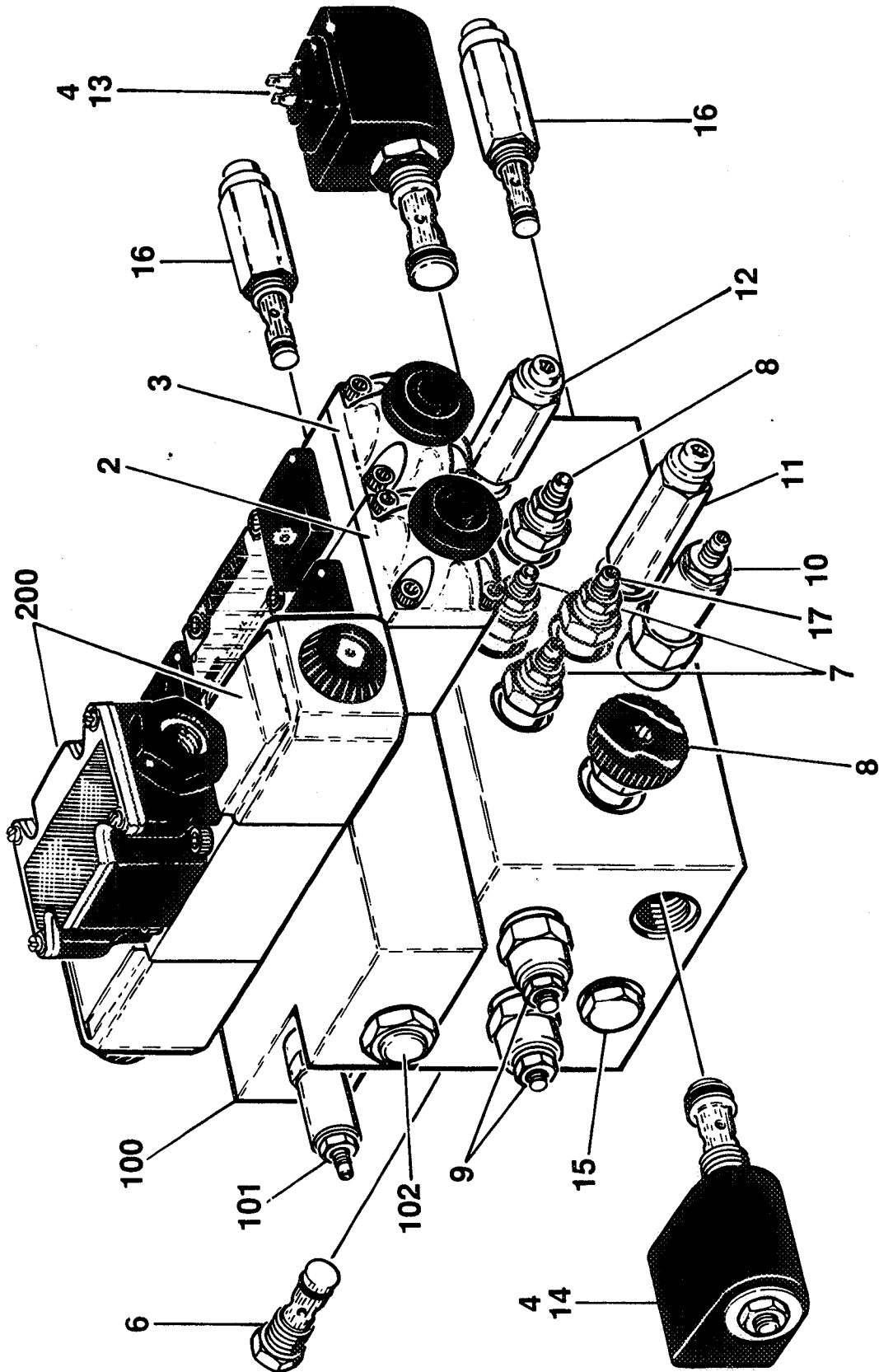
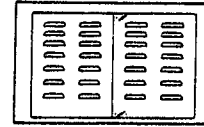

FIGURE 11-2-4. CONTROL VALVE ASSEMBLY - HYDRO-AIR
(MACHINES WITH PROPORTIONAL DRIVE).



SECTION 11-2 GROUND COMPONENTS

SECTION 11-2 GROUND COMPONENTS



SECTION 11-2 GROUND COMPONENTS

FIGURE & ITEM NO	PART NUMBER	DESCRIPTION	QTY.	REV.
11-2-4	0252689	CONTROL VALVE ASSEMBLY - HYDRO-AIR (MACHINES WITH PROPORTIONAL DRIVE)	Ref.	A
		CONTROL VALVE ASSEMBLY (INCLUDES ITEMS 1-16)	Ref.	
		NOTE: Identify by P/n stamped on the following components before ordering replacement parts. Shape of components may vary.		
-1	Not Used			
-2	4640745	Rexroth Directional Valve Assembly (Lift/Hi-Drive)	1	
	7012726	Coil - 1 Prong (Rexroth)	1	
	7012732	Coil - 3 Prong (Rexroth)	1	
	7012725	Seal Kit (Rexroth)	1	
-3	4640740	Rexroth Directional Valve Assembly (Steer)	1	
	7012727	Coil (Rexroth)	2	
	7012725	Seal Kit (Rexroth)	1	
-4	7012900	Coil - 20 Volt (Hydraforce)	2	
-5	Not Used			
-6	7012930	Valve, Check	1	
	2900756	Seal Kit (Hydraforce CV10-20-0-N-5)	1	
-7	7010544	Valve, Flow Control (Brake Speed and Lift/Lower Speed Adjustments)	2	
	7012901	Seal Kit (Hydraforce FC10-20A-0-N) (1 Per Cartridge)	2	
-8	7012933	Valve, Needle (Tow and Creep Adjustments)	2	
	7012901	Seal Kit (Hydraforce NV10-20A-0-N) (1 Per Cartridge)	2	
-9	7004361	Valve, Load Control (Drive Motion Adjustments)	2	
	2900706	Seal Kit (1 Per Cartridge)	2	
-10	7012934	Valve, Sequence (Hi-Drive Kickout Adjustment)	1	
	2900707	Seal Kit (Hydraforce PS10-32A-0-N-15/11)	1	
-11	7012932	Valve, Relief (P1 Relief Pressure Adjustment) (Hydraforce Version)	1	
	2900708	Seal Kit (Hydraforce RV10-20H-0-N-33/27)	1	
-12	7012932	Valve, Relief (P2 Relief Pressure Adjustment)	1	
	2900708	Seal Kit (Hydraforce RV10-20H-0-N-33/27)	1	
-13	7012920	Valve, Solenoid - Less Coil (Mid-Drive) (Hydraforce SV10-25-0-N-00) (Order Coil Separately)	1	
	2900708	Seal Kit	1	
-14	7012919	Valve, Solenoid - Less Coil (Positive Traction) (Hydraforce SV10-42-0-N-00) (Order Coil Separately)	1	
	7012903	Seal Kit	1	

SECTION 11-2 GROUND COMPONENTS

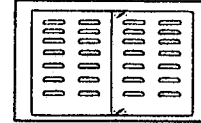

FIGURE & ITEM NO	PART NUMBER	DESCRIPTION	QTY.	REV.
11-2-4	0252689	CONTROL VALVE ASSEMBLY - HYDRO-AIR (MACHINES WITH PROPORTIONAL DRIVE) (CONTINUED)	Ref.	A
-15	7012929	Valve, Flow Divider	1	
	7012904	Seal Kit (Hydraforce FD10-40-0-N-44)		
-16	7012931	Valve, Relief (Steer Relief Adjustments)	2	
	2900708	Seal Kit (Hydraforce RV10-20H-N-33/15 and RV10-26H-N-30/15) (1 Per Cartridge)	2	
-17	7012912	Valve, Relief (Lift Relief Pressure) (Machines Built after June 1993 Only)	1	
	7010541	Seal Kit (Hydraforce RV08-20A-0-N-33)	1	
-100	4640736	LOAD SENSING VALVE ASSEMBLY	Ref.	—
-101	7010511	Valve, Load Sensing (Vickers/Modular Controls DPS2-2907)	1	
	2900735	Seal Kit (Vickers/Modular Controls DPS2-2907)	1	
-102	7010566	Valve, Check (Vickers/Modular Controls DSV1-10-B-0)	1	
	2900697	Seal Kit (Vickers/Modular Controls DSV1-10-B-0)	1	
	7012935	Valve, Check (Hydraforce LS10-30-0-N)	1	
	7012518	Seal Kit (Hydraforce LS10-30-0-N)	1	
-200	4640714	PROPORTIONAL DRIVE VALVE ASSEMBLY	Ref.	—
	7012308	Coil	2	
	7012311	Seal Kit	1	
	7012312	Mounting Kit	1	

SECTION 11-2 GROUND COMPONENTS

SECTION 11-2 GROUND COMPONENTS

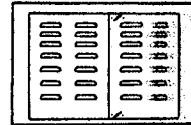
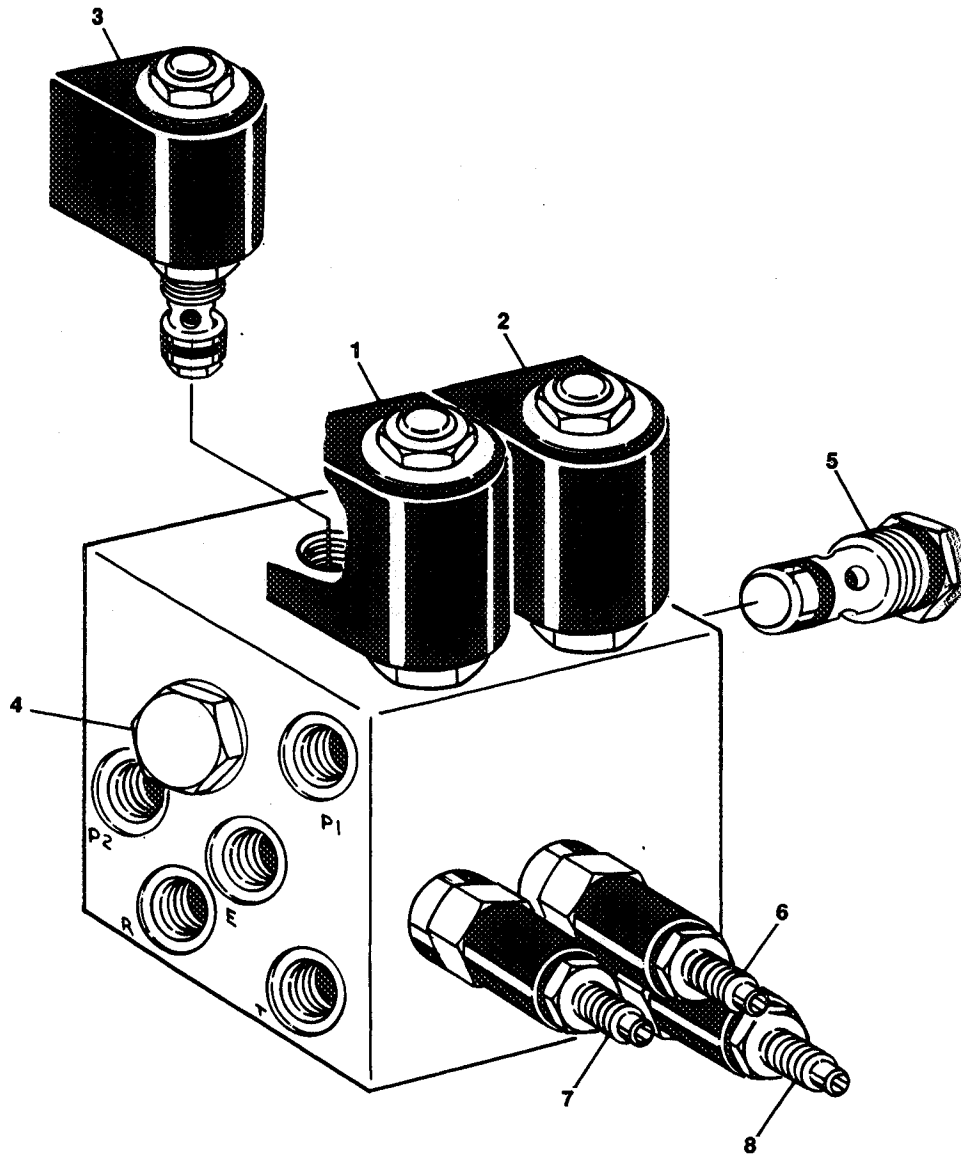
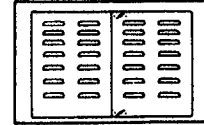

FIGURE 11-2-5. CONTROL VALVE ASSEMBLY - HYDRO AIR
(HYDRAULICALLY EXTENDED DECK OPTION).



SECTION 11-2 GROUND COMPONENTS

SECTION 11-2 GROUND COMPONENTS



SECTION 11-2 GROUND COMPONENTS

FIGURE & ITEM NO	PART NUMBER	DESCRIPTION	QTY.	REV.
11-2-5	4640870	CONTROL VALVE ASSEMBLY - HYDRO AIR (HYDRAULICALLY EXTENDED DECK OPTION)	Ref.	—
—1	7012956	Solenoid Cartridge Assembly	1	
	7012900	Coil	1	
	7010543	Seal Kit	1	
—2	7012956	Solenoid Cartridge Assembly	1	
	7012900	Coil	1	
	7010543	Seal Kit	1	
—3	7012957	Solenoid Cartridge Assembly	1	
	7012958	Coil	1	
	7012540	Seal Kit	1	
—4	7012921	Check Cartridge Assembly	1	
	7012540	Seal Kit	1	
—5	7012921	Check Cartridge Assembly	1	
	7012540	Seal Kit	1	
—6	7012912	Relief Cartridge Assembly	1	
	7010541	Seal Kit	1	
—7	7010540	Relief Cartridge Assembly	1	
	7010541	Seal Kit	1	
—8	7010540	Relief Cartridge Assembly	1	
	7010541	Seal Kit	1	
—9	Not Serviced	Manifold	1	

SECTION 11-2 GROUND COMPONENTS

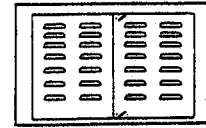
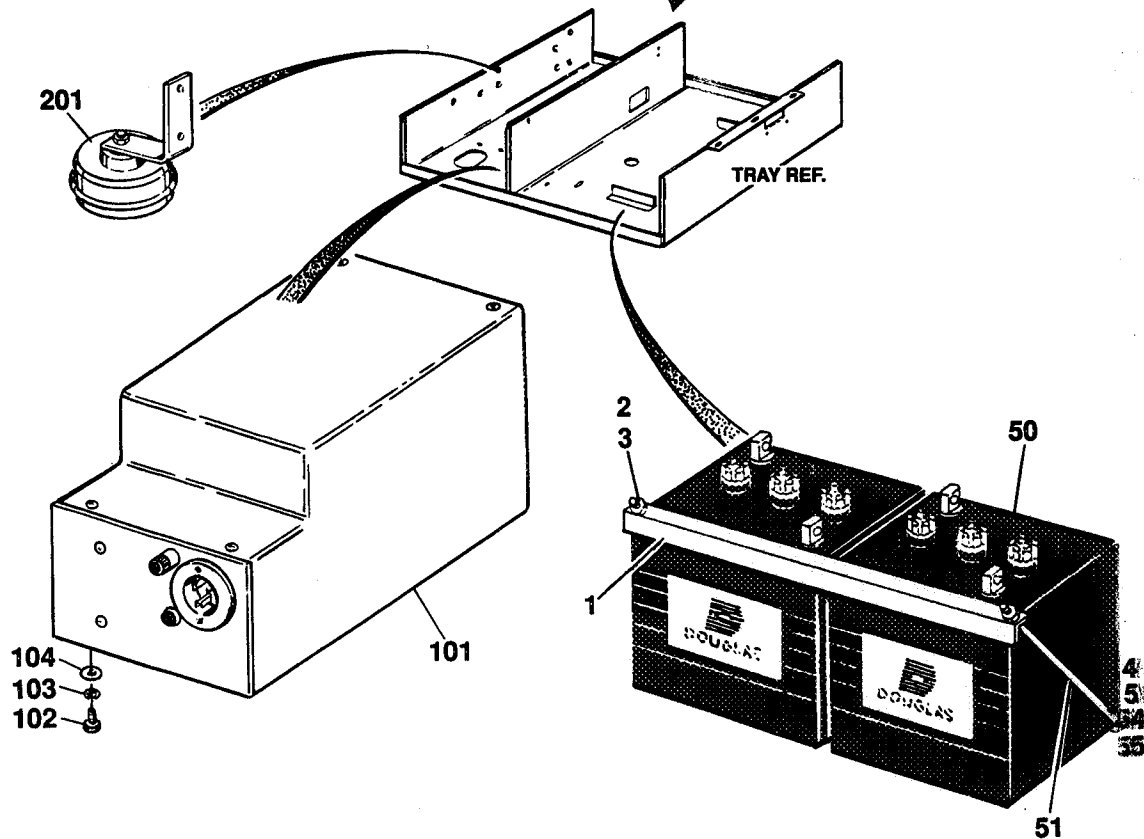
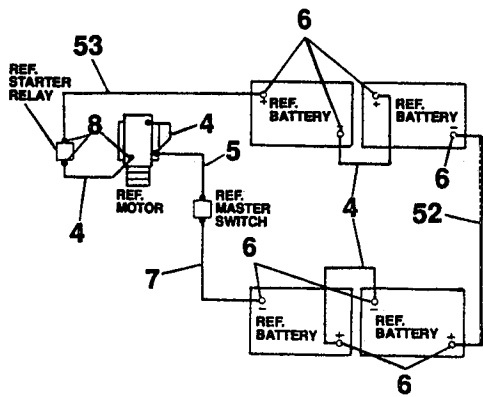
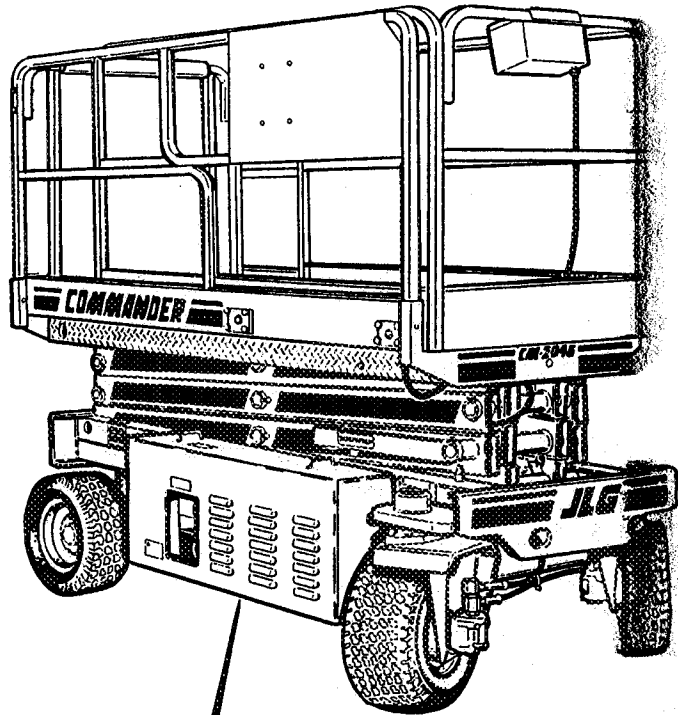

FIGURE 11-2-6. BATTERIES AND CHARGERS INSTALLATION.

NOTE: CM2046 SHOWN USE AS A REFERENCE FOR OTHER MODELS



SECTION 11-2 GROUND COMPONENTS

SECTION 11-2 GROUND COMPONENTS

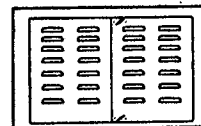

SECTION 11-2 GROUND COMPONENTS

FIGURE & ITEM NO	PART NUMBER	DESCRIPTION	QTY.	REV.
11-2-6		BATTERIES AND CHARGERS INSTALLATION	Ref.	
	1281464	BATTERIES INSTALLATION (STANDARD PARTS)	Ref.	G
-1	0181583	Angle, Mounting - Battery	2	
-2	4751400	Flatwasher 1/4"	4	
-3	3311405	Locknut 1/4"-20NC	4	
-4	1060221	Cable, Battery - 12 in./30.5cm Length	4	
-5	1060080	Cable, Battery - 30 in./76cm Length	1	
-6	0840031	Boot, Terminal Cover	8	
-7	1060130	Cable, Battery - 22 in./56cm Length	1	
-8	0840025	Boot, Terminal	3	
	0251354	BATTERIES INSTALLATION - CM2038 (VARIABLE PARTS)	Ref.	G
-50	0400069	Battery (Wet Standard) (Douglas 6V/225)	4	
	0400112	Battery (Dry Standard) (Douglas 6V/225)	4	
-51	3841069	Rod, Holddown	4	
-52	1060364	Cable, Battery - 30 in./76cm Length	1	
-53	1060400	Cable, Battery - 48 in./122cm Length	1	
	0251352	BATTERIES INSTALLATION - CM2046 WITH STANDARD BATTERIES BUILT PRIOR TO JUNE 1993 (VARIABLE PARTS)	Ref.	H
	0254247	BATTERIES INSTALLATION - CM2046 WITH STANDARD BATTERIES BUILT JUNE 1993 TO PRESENT (VARIABLE PARTS)	Ref.	A
-50	0400069	Battery (Wet Standard) (Douglas 6V/225)	4	
	0400112	Battery (Dry Standard) (Douglas 6V/225)	4	
-51	3841069	Rod, Holddown	4	
-52	1060054	Cable, Battery - 36 in./96.5cm Length	1	
-53	1060149	Cable, Battery - 54 in./137cm Length	1	
-54	0641408	Bolt 1/4"-20NC x 1" (June 1973 to Present)	4	
-55	0181722	Angle, Mounting (June 1973 to Present)	2	
	0251352	BATTERIES INSTALLATION - CM2546 AND CM2558 WITH STANDARD BATTERIES (VARIABLE PARTS)	Ref.	H
-50	0400069	Battery (Wet Standard) (Douglas 6V/225)	4	
	0400112	Battery (Dry Standard) (Douglas 6V/225)	4	
-51	3841069	Rod, Holddown	4	
-52	1060149	Cable, Battery - 36 in./91.5cm Length	1	
-53	1060149	Cable, Battery - 54 in./137cm Length	1	
-54	Not Required			
-55	Not Required			
	0251353	BATTERIES INSTALLATION - CM2046 WITH HI-OUTPUT BATTERIES BUILT PRIOR TO JUNE 1993 (VARIABLE PARTS)	Ref.	H
	0254248	BATTERIES INSTALLATION - CM2046 WITH HI-OUTPUT BATTERIES BUILT JUNE 1993 TO PRESENT (VARIABLE PARTS)	Ref.	A
-50	0400055	Battery (Wet Hi-Output) (Douglas 6V/370-S)	4	
	0400107	Battery (Dry Hi-Output) (Douglas 6V/370-S)	4	

SECTION 11-2 GROUND COMPONENTS

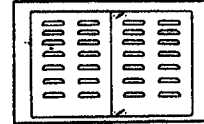

SECTION 11-2 GROUND COMPONENTS

FIGURE & ITEM NO	PART NUMBER	DESCRIPTION	QTY.	REV.
------------------	-------------	-------------	------	------

11-2-6		BATTERIES AND CHARGERS INSTALLATION (CONTINUED)	Ref.	
-51	3841094	Rod, Holddown	4	
-52	1060054	Cable, Battery - 36 in./91.5cm Length	1	
-53	1060149	Cable, Battery - 54 in./137cm Length	1	
-54	0641408	Bolt 1/4"-20NC x 1" (June 1993 to Present)	4	
-55	0181722	Angle, Mounting (June 1993 to Present)	2	
	0251353	BATTERIES INSTALLATION - CM2046 AND CM2558 WITH HI-OUTPUT BATTERIES (VARIABLE PARTS)	Ref.	H
-50	0400055	Battery (Wet Hi-Putput) (Douglas 6V-370-S)	4	
	0400107	Battery (Dry Hi-Output) (Douglas 6V-370-S)	4	
-51	3841094	Rod, Holddown	4	
-52	1060054	Cable, Battery - 36 in./91.5cm Length	1	
-53	1060149	Cable, Battery - 54 in./137cm Length	1	
-54	Not Required			
-55	Not Required			
	0251347	BATTERY CHARGER INSTALLATION	Ref.	A
-101	0400087	Battery Charger Assembly (See Figure 11-2-7) for Breakdown)	1	
-102	0641406	Bolt 1/4"-20NC x 3/4"	2	
-103	4761400	Lockwasher 1/4"	2	
-104	4751400	Flatwasher 1/4"	2	
	0251788	HORN INSTALLATION - WITH STEEL CONTROL BOX (OPTION)	Ref.	B
	0253465	HORN INSTALLATION - WITH MOLDED CONTROL BOX (OPTION)	Ref.	A
-201	0140022	Alarm, Horn	1	

SECTION 11-2 GROUND COMPONENTS

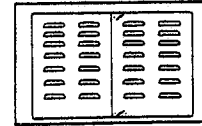
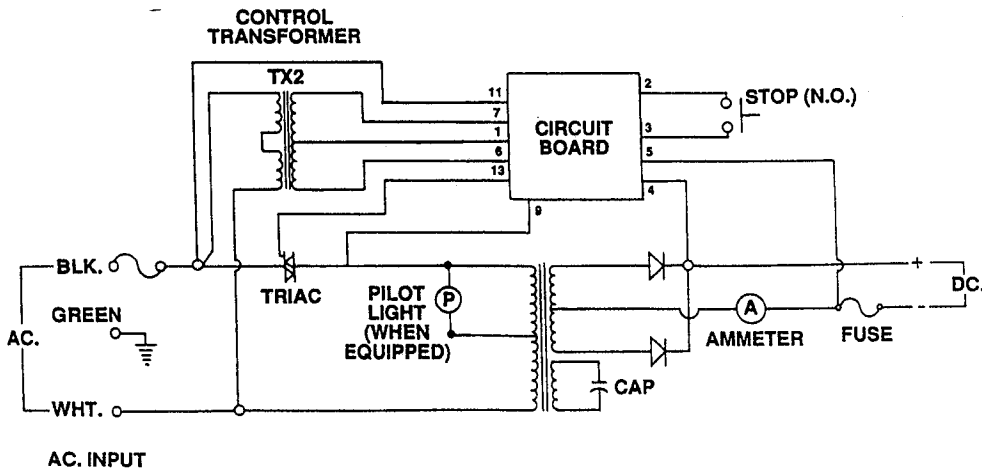
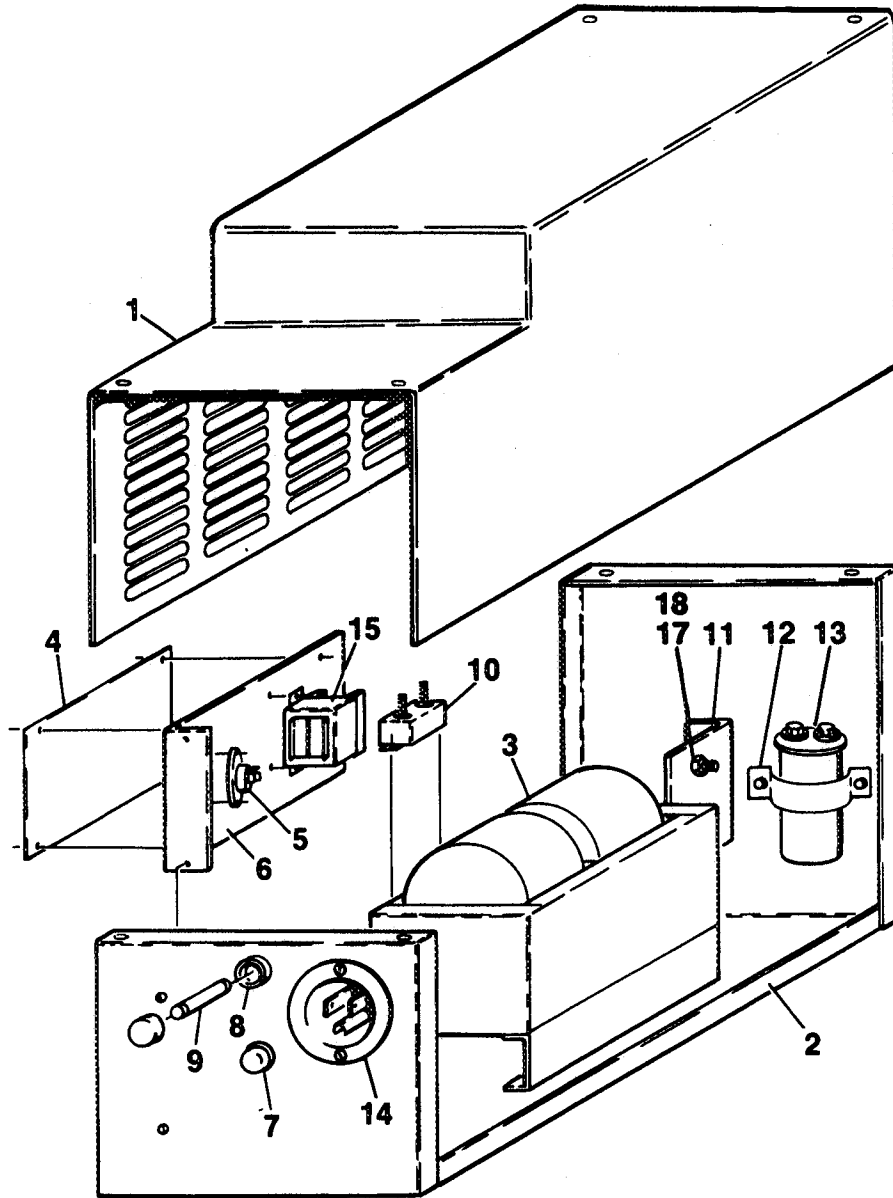
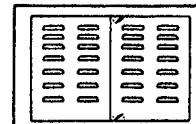

FIGURE 11-2-7. BATTERY CHARGER ASSEMBLY.



SECTION 11-2 GROUND COMPONENTS

SECTION 11-2 GROUND COMPONENTS



SECTION 11-2 GROUND COMPONENTS

FIGURE & ITEM NO	PART NUMBER	DESCRIPTION	QTY.	REV.
11-2-7	0400087	BATTERY CHARGER ASSEMBLY	Ref.	B
-1	Not Serviced	Cover, Case	1	
-2	Not Serviced	Case, Main	1	
-3	7011502	Transformer	1	
-4		Circuit Board Options:	1	
	7011515	Board, Circuit - Use 7011665 as Replacement (Without LED Lights) (Prior to Nov. 1992)		
	7011653	Board, Circuit - Use 7011665 as Replacement (With LED Lights) (Nov. 1992 to January 1995)		
	7011665	Board, Circuit (With LED Lights) (January 1995 to Present)		
	70111680	Harness (8 Wire From PC Board)	1	
-5	7011517	Triac	1	
-6	7011516	Bracket, Mounting - Circuit Board	1	
-7	7011506	Light, Pilot (When Equipped)	1	
-8	7011507	Holder, Fuse	1	
-9	7011508	Fuse - 15 Amp	1	
-10	7011509	Breaker, Circuit	1	
-11	7011558	Heatsink	1	
-12	7011560	Strap, Mounting - Condenser	1	
-13	7011512	Condenser - 7.5 mfd	1	
-14	7011513	Receptacle - AC	1	
-15	7011518	Control	1	
-16	Not Used			
-17	7011576	Diode	2	
-18	7011596	Varistor	1	

Note: See Serial Number Nameplate located on Charger. First line is the Charger Spec and Date Code. Example: BA515 (Spec) AP (Date Code). First Letter in the Date Code indicates Month (A-January/B-February/C-March/etc. with exception of Letter "I" which is not used). Second Letter indicates Year (N-1992/O-1993/P-1994/S-1995/etc.)

SECTION 11-2 GROUND COMPONENTS

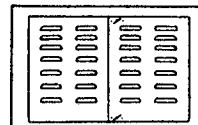
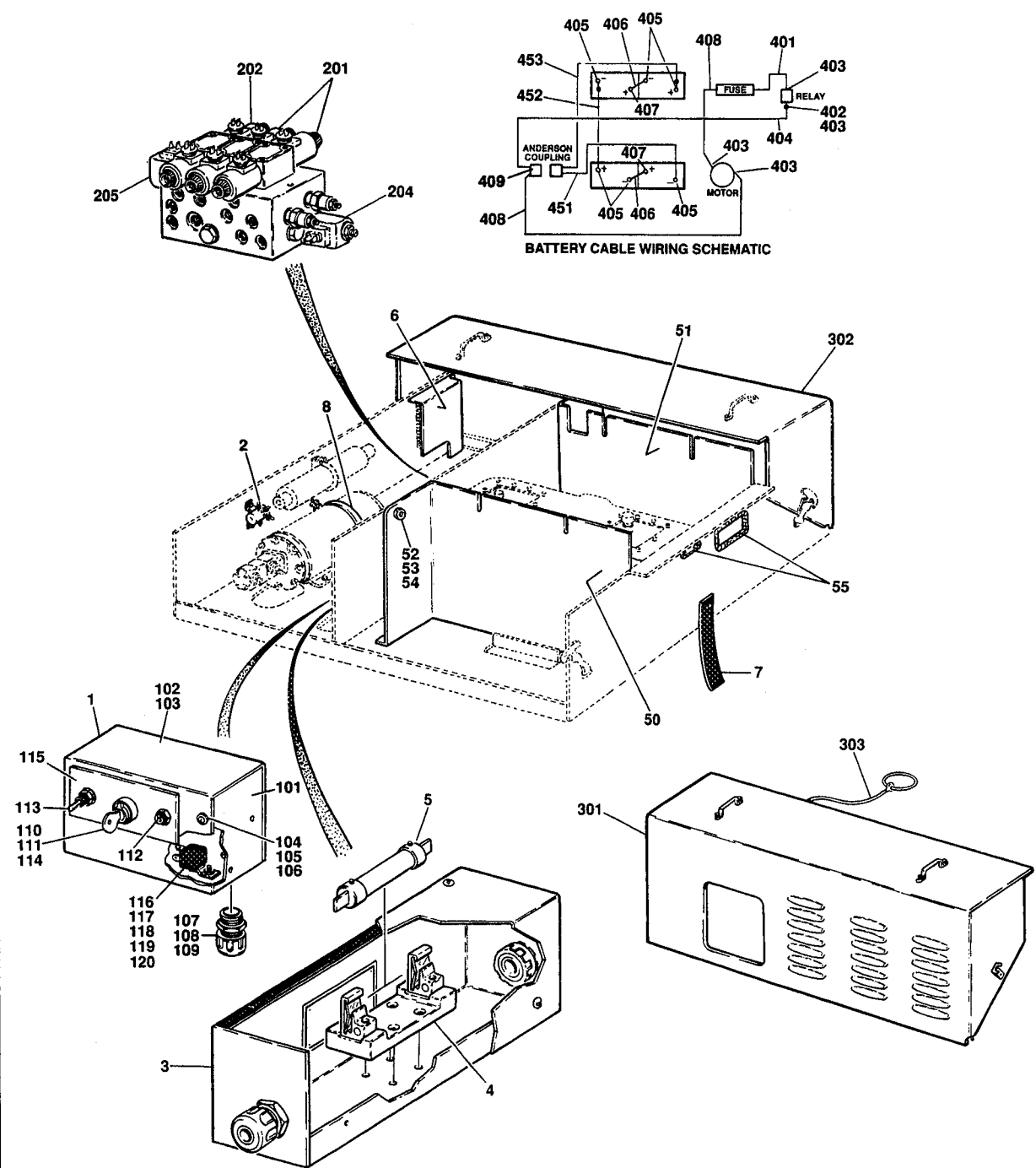
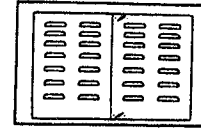

FIGURE 11-2-8. UL LISTED COMPONENTS INSTALLATION - GROUND COMPONENTS.

SECTION 11-2 GROUND COMPONENTS



SECTION 11-2 GROUND COMPONENTS



SECTION 11-2 GROUND COMPONENTS

FIGURE & ITEM NO	PART NUMBER	DESCRIPTION	QTY.	REV.
11-2-8		UL LISTED COMPONENTS INSTALLATION - GROUND COMPONENTS	Ref.	
		Note: Shown here are non-standard components used only on UL listed machines. Loss of UL approval will result if unapproved parts are used as replacements.		
	1281703	GROUND CONTROLS INSTALLATION (STANDARD UL PARTS)	Ref.	—
—1	0860748	Ground Control Box Assembly (See Items 101-120 for Breakdown)	1	
—2	3740073	Relay - 200 Amp/24VDC	1	
—3	0860626	Fuse Box Assembly	1	
	3533904	Lid	1	
	4460051	Connector, Strain Relief	2	
	3300048	Locknut, Conduit	2	
	0960238	Bushing	2	
	3251960	Nameplate - Fuse	1	
—4	2400027	Fuseholder	1	
—5	2400025	Fuse - 200 Amp	1	
—6	3535590	Cover - Terminal Strip	1	
—7	4240084	Strap, Static	1	
—8	2901207	Motor Band Kit	1	
	0252593	GROUND CONTROLS INSTALLATION - CM2033 WITH BANG-BANG DRIVE (VARIABLE UL PARTS)	Ref.	C
	0252307	GROUND CONTROLS INSTALLATION - CM2033 WITH PROPORTIONAL DRIVE/VARIABLE UL PARTS)	Ref.	D
—50	4060825	Shield, Battery	1	
—51	4060826	Shield, Battery	1	
—52	Not Used			
—53	Not Used			
—54	Not Used			
—55	Not Used			
	0252594	GROUND CONTROLS INSTALLATION - CM2046 WITH BANG-BANG DRIVE (VARIABLE UL PARTS)	Ref.	C
	0252308	GROUND CONTROLS INSTALLATION - CM2046 WITH PROPORTIONAL DRIVE (VARIABLE UL PARTS)	Ref.	D
	0252595	GROUND CONTROLS INSTALLATION - CM2546 AND AND CM2558 WITH BANG-BANG DRIVE (VARIABLE UL PARTS)	Ref.	B
	0252309	GROUND CONTROLS INSTALLATION - CM2546 AND AND CM2558 WITH PROPORTIONAL DRIVE (VARIABLE UL PARTS)	Ref.	D
—50	4060820	Shield, Battery	1	
—51	4060821	Shield, Battery	1	

SECTION 11-2 GROUND COMPONENTS

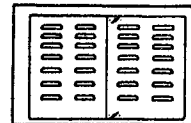

SECTION 11-2 GROUND COMPONENTS

FIGURE & ITEM NO	PART NUMBER	DESCRIPTION	QTY.	REV.
11-2-8		UL LISTED COMPONENTS INSTALLATION - GROUND COMPONENTS (CONTINUED)	Ref.	
-52	4460328	Connector, Strain Relief	2	
-53	0960238	Bushing	2	
-54	3300048	Locknut, Conduit	2	
-55	2540002	Grommet	4 ft.	
	0860748	GROUND CONTROL BOX ASSEMBLY (STANDARD UL PARTS)	Ref.	—
-101	0860747	Box	1	
-102	3535575	Lid	1	
-103	4420008	Tape, Insulation	2 ft.	
-104	0750806	Screw, Self-Tap #8 x 3/4"	4	
-105	3300177	Nut, Tinnerman	4	
-106	4740120	Washer, Nylon	4	
-107	4460052	Connector, Strain Relief	1	
-108	3300047	Locknut, Conduit	1	
-109	0960239	Bushing	1	
-110	4360290	Keyswitch, Master	1	
	7010698	Key, Replacement	1Set	
-111	4360267	Block, Switch	1	
-112	4360070	Breaker, Circuit	1	
-113	4360202	Switch, Toggle	1	
-114	4360281	Block, Contact	1	
-115	3252143	Nameplate	1	
-116	3740069	Relay, Power - 24VDC	1	
-117	3911012	Screw, Machine #10-24NC x 3/4"	1	
-118	4751000	Flatwasher #10	1	
-119	4761000	Lockwasher #10	1	
-120	3311001	Nut #10-24NC	1	
	0253621	VALVE ASSEMBLY MODIFICATIONS - UL	Ref.	—
-201	4640802	Valve Assembly	A/R	
		- With Bang-Bang Drive (Drive and Hi-Drive/Lift Sections)	2	
		- With Proportional Drive (Hi-Drive/Lift Section Only)	1	
	7010534	Coil (2 Per Section)	A/R	
	2900780	Seal Kit (1 Per Section)	A/R	
-202	4640803	Valve Assembly (Steer Section)	1	
	7010534	Coil	2	
	2900780	Seal Kit	1	
-203	Not Used			
-204	4640805	Valve, Cartridge (Posi-Trac)	1	
	7010551	Coil - 16VDC	1	
	7010507	Shell, Coil	1	
-205	4640806	Valve, Cartridge (Mid Drive)	1	
	7010551	Coil - 16VDC	1	
	7010507	Shell, Coil	1	

SECTION 11-2 GROUND COMPONENTS

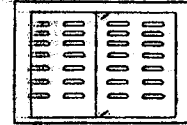

SECTION 11 - 2 GROUND COMPONENTS

FIGURE & ITEM NO	PART NUMBER	DESCRIPTION	QTY.	REV.
11-2-8		UL LISTED COMPONENTS INSTALLATION - GROUND COMPONENTS (CONTINUED)	Ref.	
	0252608	SIDE COVER INSTALLATION - CM2033 (VARIABLE UL PARTS) (NOT SHOWN)	Ref.	—
—301	4060818	Cover, Side (RH)	1	
—302	4060819	Cover, Side (LH)	1	
—303	1060380	Cable, Lanyard	2	
	0252315	SIDE COVERS INSTALLATION - CM2046, CM2546 AND CM2558 (VARIABLE UL PARTS)	Ref.	—
—301	4060799	Cover, Side (RH)	1	
—302	4060801	Cover, Side (LH)	1	
—303	1060380	Cable, Lanyard	2	
	1281761	BATTERIES INSTALLATION (STANDARD UL PARTS)	Ref.	B
—401	1060182	Cable, Battery	1	
—402	4460199	End, Terminal	4	
—403	0840025	Boot, Terminal	4	
—404	1060180	Cable, Battery	1	
—405	0840032	Boot, Terminal (RH)	6	
—406	1060084	Cable, Battery	2	
—407	0840031	Boot, Terminal (LH)	2	
—408	1060080	Cable, Battery	2	
—409	4460490	Boot, Terminal	2	
	0252598	BATTERIES INSTALLATION - CM2033 (VARIABLE UL PARTS)	Ref.	—
—451	1060427	Cable Assembly	1	
—452	1060103	Cable Assembly	1	
—453	1060426	Cable Assembly	1	
	0252596	BATTERIES INSTALLATION - CM2046 WITH STANDARD BATTERIES BUILT PRIOR TO JUNE 1993 (VARIABLE UL PARTS)	Ref.	C
	0254259	BATTERIES INSTALLATION - CM2046 WITH STANDARD BATTERIES BUILT JUNE 1993 TO PRESENT (VARIABLE UL PARTS)	Ref.	A
	0252597	BATTERIES INSTALLATION - CM2046 WITH HI-OUTPUT BATTERIES BUILT PRIOR TO JUNE 1993 (VARIABLE UL PARTS)	Ref.	C
	0254249	BATTERIES INSTALLATION - CM2046 WITH HI-OUTPUT BATTERIES BUILT JUNE 1993 TO PRESENT (VARIABLE UL PARTS)	Ref.	C
	0252596	BATTERIES INSTALLATION - CM2546 AND CM2558 WITH STANDARD BATTERIES (VARIABLE UL PARTS)	Ref.	C

SECTION 11-2 GROUND COMPONENTS

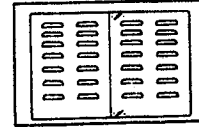

SECTION 11-2 GROUND COMPONENTS

FIGURE & ITEM NO	PART NUMBER	DESCRIPTION	QTY.	REV.
11-2-8		UL LISTED COMPONENTS INSTALLATION - GROUND COMPONENTS (CONTINUED)	Ref.	
	0252597	BATTERIES INSTALLATION - CM2546 AND CM2558 WITH HI-OUTPUT BATTERIES (VARIABLE UL PARTS)	Ref.	C
-451	1060401	Cable Assembly	1	
-452	1060400	Cable Assembly	1	
-453	1060149	Cable Assembly	1	
	0400108	BATTERY CHARGER ASSEMBLY - OFFBOARD (NOT SHOWN)	Ref.	—
	0400087	Battery Charger Assembly (See Figure 11-2-7 for Breakdown)	1	
	1060308	Cable, Electrical - 12/3	8 ft.	
	4460025	Connector, Anderson	1	

SECTION 1-3

SIZZOR ARMS

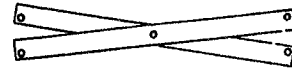

TABLE OF CONTENTS

FIGURE NO.	TITLE	PAGE NO.
11-3-1	Sizzor Arms Installation - CM2033 and CM2046	11-3-2
11-3-2	Sizzor Arms Installation - CM2546 and CM2558	11-3-4

SECTION 11-3 SIZZOR ARMS

SECTION

11-3

SIZZOR ARMS

FIGURE 11-3-1. SIZZOR ARMS INSTALLATION - CM2033 AND CM2046.



SECTION 11-3 SIZZOR ARMS

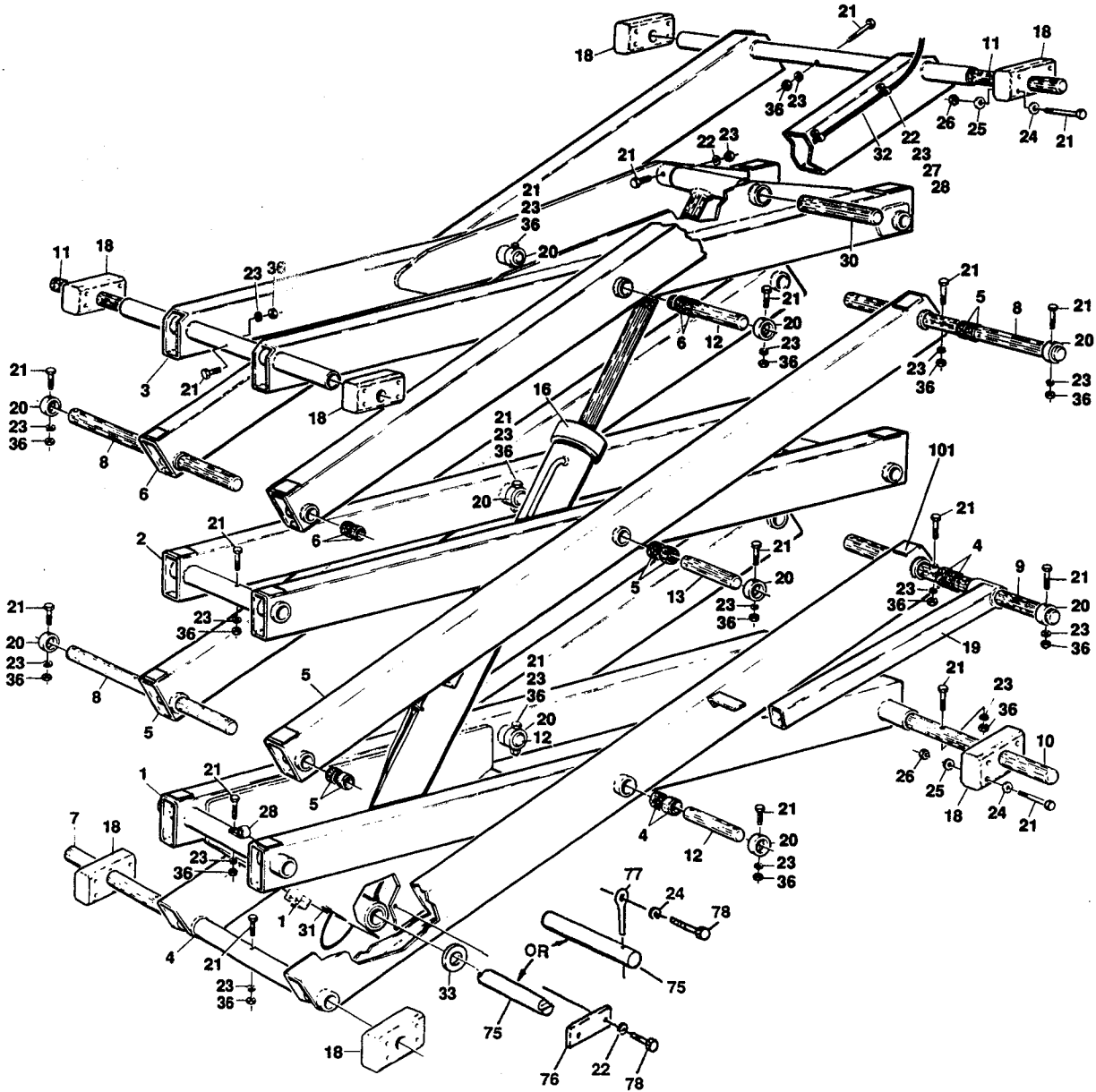

SECTION 11-3 SIZZOR ARMS



SECTION 11-3 SIZZOR ARMS

FIGURE & ITEM NO	PART NUMBER	DESCRIPTION	QTY.	REV.
11-3-1	0251105	SIZZOR ARMS INSTALLATION - CM2033 AND CM2046 (STANDARD PARTS)	Ref.	K
	0254838	SIZZOR ARMS INSTALLATION - CM2033 WITH HYDRAULICALLY EXTENDED PLATFORM (STANDARD PARTS)	Ref.	B
	0251105	SIZZOR ARMS INSTALLATION - CM2046 WITH HYDRAULICALLY EXTENDED PLATFORM (STANDARD PARTS)	Ref.	K
	2901375	Arm Kit - CM2033 and CM2046	1	—
	2901368	Arm Kit - CM2033 with Hydraulically Extended Platform	1	—
	2901375	Arm Kit - CM2046 with Hydraulically Extended Platform	1	—
—1	0200416	Arm Weldment (Bottom Inboard) (Prior to March 1993)	1	
	0200508	Arm Weldment (Bottom Inboard) (March 1993 to Present)	1	
	1320052	Clamp, Hose	1	
—2	0200417	Arm Weldment (Mid Inboard)	1	
—3	0200418	Arm Weldment (Top Inboard) (Standard CM2033 and All CM2046)	1	
	0200527	Arm Weldment (Top Inboard) (CM2033 with Hydraulically Extended Platform)	1	
—4	0200420	Arm Weldment (Bottom Outboard)	1	
	0961481	Bushing, Superoilite (8 Per Arm)	8	
—5	0200421	Arm Weldment (Mid Outboard)	2	
	0961481	Bushing, Superoilite (6 Per Arm)	12	
—6	0200422	Arm Weldment (Top Outboard) (Standard CM2033 and All CM2046)	1	
	0200528	Arm Weldment (Top Outboard) (CM2033 with Hydraulically Extended Platform)	1	
	0961481	Bushing, Superoilite (8 Per Arm)	8	
—7	3421784	Pin, Pivot (Bottom Rear)	1	
—8	3421781	Pin, Pivot (Mid Front, Mid Rear and Top Rear)	3	
—9	3421782	Pin, Pivot (Bottom Front)	1	
—10	3421783	Pin, Pivot (Bottom Front)	1	
—11	3421785	Pin, Pivot (Top Rear and Top Front) (Standard CM2033 and All CM2046)	2	
	3422368	Pin, Pivot (Top Rear and Top Front) (CM2033 with Hydraulically Extended Platform)	1	
—12	3421786	Pin, Pivot (Top Center and Bottom Center)	4	
—13	3421795	Pin, Pivot (Mid Center)	2	
—14	Not Used			
—15	Not Used			
—16	Not Used			
—17		Lift Cylinder Sub-Assembly (See Section 11-5 for Breakdown)	1	
—18	3340601	Pad, Sliding Block	8	
—19	4843090	Safety Prop Weldment	1	
—20	1440224	Collar, Pivot Pin	14	
—21	0641522	Bolt 5/16"-18NC x 2 3/4"	A/R	
	0641516	Bolt 5/16"-18NC x 2"	A/R	
—22	4761500	Lockwasher 5/16"	15	
—23	3311501	Nut 5/16"-18NC	38	

SECTION 11-3 SIZZOR ARMS

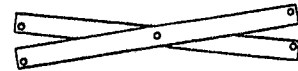

FIGURE & ITEM NO	PART NUMBER	DESCRIPTION	QTY.	REV.
11-3-1	0251105	SIZZOR ARMS INSTALLATION - CM2033 AND CM2046 (STANDARD PARTS) (CONTINUED)	Ref.	1
-24	4751500	Flatwasher 5/16"	24	
-25	4711500	Flatwasher 5/16" Narrow	17	
-26	3311505	Locknut 5/16"-18NC	16	
-27	4300038	Stud (Welded on Part)	8	
-28	1320061	Clamp	9	
-29	0641506	Bolt 5/16"-18NC	2	
-30	3421790	Pin, Attach (Lift Cylinder Rod)	1	
-31	2540002	Grommet	1 ft./3m	
-32	2820025	Guard, Loom	7 ft./2.2m	
-33	4740155	Washer, Thrust	1	
-34	Not Used			
-35	Not Used			
-36	3311505	Locknut 5/16"-18NC	23	
		SIZZOR ARMS INSTALLATION (PRIOR TO MARCH 1993) (VARIABLE PARTS)	Ref.	
-75	3421789	Pin, Attach (Lift Cylinder Barrel)	1	
-76	3534472	Plate, Retainer	2	
-77	Not Required			
-78	0641506	Bolt 5/16"-18NC x 3/4"	4	
		SIZZOR ARMS INSTALLATION (MARCH 1993 TO PRESENT) (VARIABLE PARTS)	Ref.	
-75	3422215	Pin, Attach (Lift Cylinder Barrel)	1	
-76	Not Required			
-77	3841143	Pin, Keeper	1	
-78	0641509	Bolt 5/16"-18NC x 1 1/8"	1	
	0252586	ARM PADS INSTALLATION	Ref.	-
-101	3340645	Pad	16	

SECTION 11-3 SIZZOR ARMS

SECTION

11-3

SIZZOR ARMS

FIGURE 11-3-2. SIZZOR ARMS INSTALLATION -
CM2546 AND CM2558.

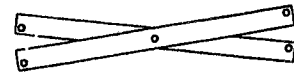

SECTION
11-3
SIZZOR
ARMS

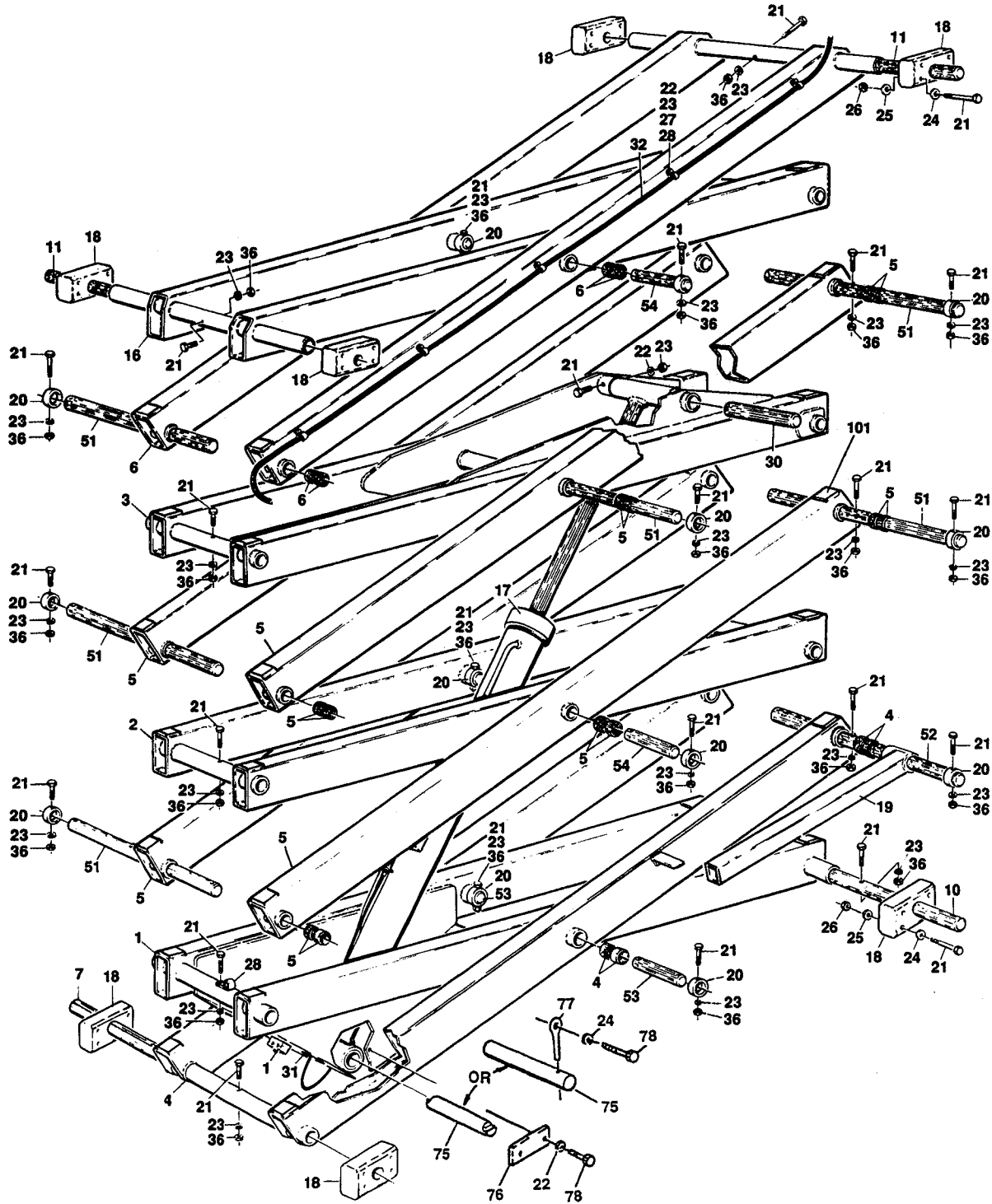

SECTION 11-3 SIZZOR ARMS



SECTION 11-3 SIZZOR ARMS

FIGURE & ITEM NO	PART NUMBER	DESCRIPTION	QTY.	REV.
11-3-2	1281583	SIZZOR ARMS INSTALLATION - CM2546 AND CM2558.	Ref.	I
		SIZZOR ARMS INSTALLATION (STANDARD PARTS)	Ref.	
	2901376	Arm Kit - CM2546 and CM2558	1	—
—1	0200416	Arm Weldment (Bottom Inboard)(Prior to March 1993)	1	
	0200508	Arm Weldment (Bottom Inboard)(March 1993 to Present)	1	
	1320052	Clamp, Hose	1	
—2	0200417	Arm Weldment (Lower Mid Inboard)	1	
—3	0200424	Arm Weldment (Upper Mid Inboard)	1	
—4	0200420	Arm Weldment (Bottom Outboard)	1	
	0961481	Bushing, Superoilite (8 Per Arm)	8	
—5	0200421	Arm Weldment (Upper and Lower Mid Outboard)	4	
	0961481	Bushing, Superoilite (6 Per Arm)	24	
—6	0200422	Arm Weldment (Top Outboard)	1	
	0961481	Bushing, Superoilite (8 Per Arm)	8	
—7	3421784	Pin, Pivot (Bottom Rear)	1	
—8	Not Used			
—9	Not Used			
—10	3421783	Pin, Pivot (Bottom Front)	1	
—11	3421785	Pin, Pivot (Top Rear and Top Front)	2	
—12	Not Used			
—13	Not Used			
—14	Not Used			
—15	Not Used			
—16	0200423	Arm Weldment (Top Inboard) (Part of Arm Kit)	1	
—17		Lift Cylinder Sub-Assembly (See Section 11-5 for Breakdown)	1	
—18	3340601	Pad, Sliding Block	8	
—19	4843090	Safety Prop Weldment	1	
—20	1440224	Collar, Pivot Pin	20	
—21	0641522	Bolt 5/16"-18NC x 2 3/4"	55	
—22	4761500	Lockwasher 5/16"	14	
—23	3311501	Nut 5/16"-18NC	39	
—24	4751500	Flatwasher 5/16"	24	
—25	4711500	Flatwasher 5/16" Narrow	17	
—26	3311505	Locknut 5/16"-18NC	16	
—27	4300038	Stud (Welded on Part)	5	
—28	1320061	Clamp	6	
—29	0641506	Bolt 5/16"-18NC	2	
—30	3421790	Pin, Attach (Lift Cylinder Rod)	1	
—31	2540002	Grommet	1 ft./3m	
—32	2820025	Guard, Loom	9 ft./2.8m	
—33	4740155	Washer, Thrust	1	
—34	Not Used			
—35	Not Used			
—36	3311505	Locknut 5/16"-18NC	33	

SECTION 11-3 SIZZOR ARMS



SECTION 11-3 SIZZOR ARMS

FIGURE & ITEM NO	PART NUMBER	DESCRIPTION	QTY.	REV.
11-3-2		SIZZOR ARMS INSTALLATION - CM2546 AND CM2558. (CONTINUED)	Ref.	
	0251106	SIZZOR ARMS INSTALLATION - STANDARD MACHINE (VARIABLE PARTS)	Ref.	K
-51	3421781	Pin, Pivot (Mid Front, Mid Rear, Upper Mid Center and Top Rear)	6	
-52	3421782	Pin, Pivot (Bottom Front)	1	
-53	3421786	Pin, Pivot (Bottom Center)	2	
-54	3421795	Pin, Pivot (Top Center and Lower Mid Center)	4	
	0251821	SIZZOR ARMS INSTALLATION - CSA SPECS (VARIABLE PARTS)	Ref.	G
-51	3421888	Pin, Pivot (Mid Front, Mid Rear, Upper Mid Center and Top Rear)	6	
-52	3421893	Pin, Pivot (Bottom Front)	1	
-53	3421890	Pin, Pivot (Bottom Center)	2	
-54	3421889	Pin, Pivot (Top Center and Lower Mid Center)	4	
		SIZZOR ARMS INSTALLATION (PRIOR TO MARCH 1993) (VARIABLE PARTS)	Ref.	
-75	3421789	Pin, Attach (Lift Cylinder Barrel)	1	
-76	3534472	Plate, Retainer	2	
-77	Not Required			
-78	0641506	Bolt 5/16"-18NC x 3/4"	4	
		SIZZOR ARMS INSTALLATION (MARCH 1993 TO PRESENT) (VARIABLE PARTS)	Ref.	
-75	3422215	Pin, Attach (Lift Cylinder Barrel)	1	
-76	Not Required			
-77	3841143	Pin, Keeper	1	
-78	0641509	Bolt 5/16"-18NC x 1 1/8"	1	
	0252587	ARM PADS INSTALLATION	Ref.	—
-101	3340645	Pad	24	

SECTION 11-4

PLATFORM

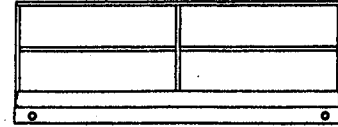

TABLE OF CONTENTS

FIGURE NO.	TITLE	PAGE NO.
11-4-1	Standard Handrails and Accessories Installation	11-4-2
11-4-2	Optional Fold-Down Handrail Installations	11-4-8
11-4-3	Optional Extendable Deck Installation With Standard Handrails	11-4-12
11-4-4	Optional Extendable Deck Installation With Fold-Down Handrails	11-4-14
11-4-5	Optional Hydraulically Extended Deck Installation with Standard Handrails ..	11-4-16
11-4-5A	Optional Hydraulically Extended Deck Installation with Fold-Down Handrails.	11-4-18
11-4-6	Steel Platform Console Box Assembly	11-4-20
11-4-7	Molded Platform Console Box Assembly	11-4-24

SECTION 11 - 4 PLATFORM

SECTION 11-4 PLATFORM

FIGURE 11-4-1. STANDARD HANDRAILS AND ACCESSORIES INSTALLATION.

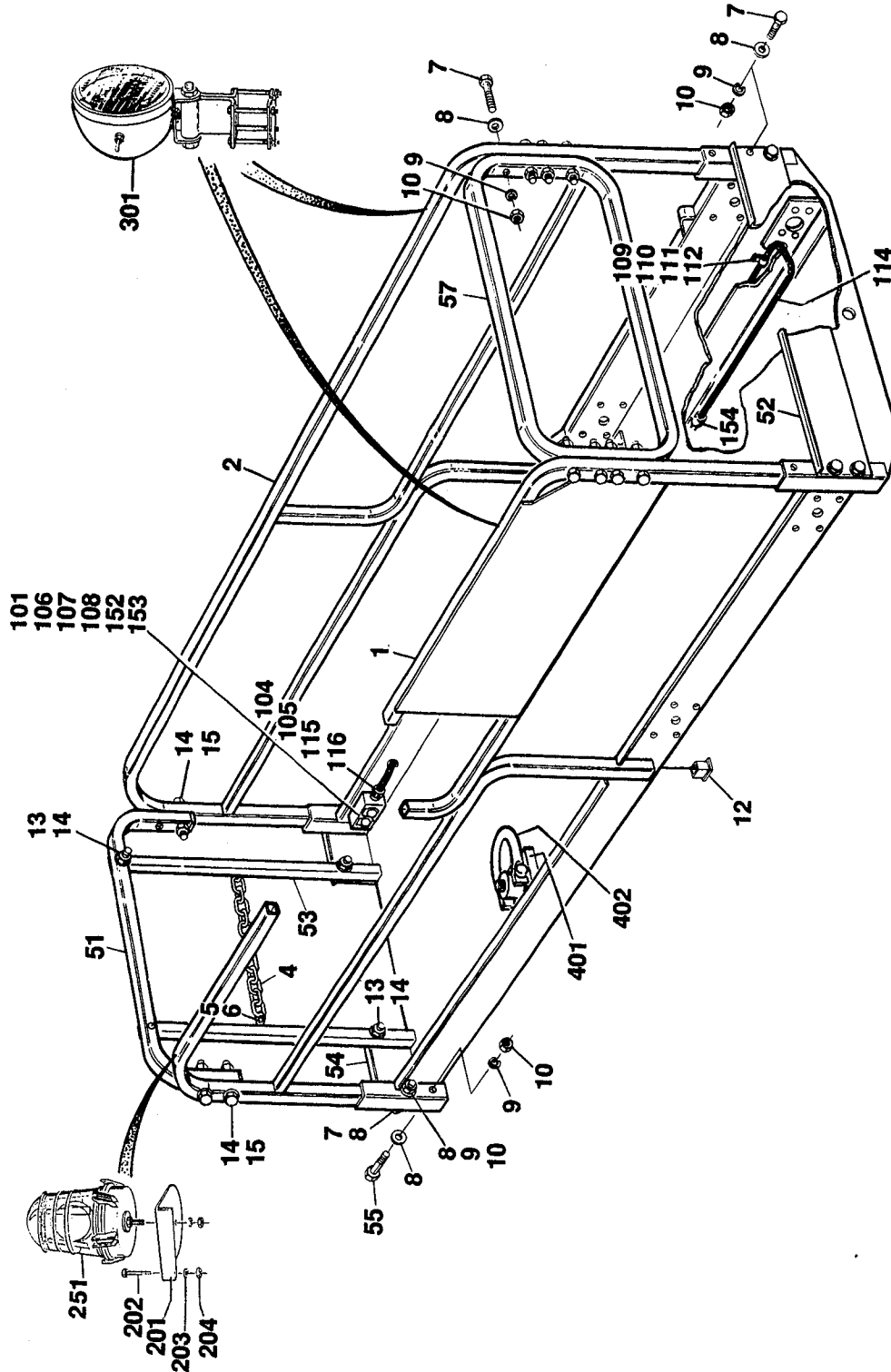

SECTION 11-4 PLATFORM

SECTION 11-4 PLATFORM

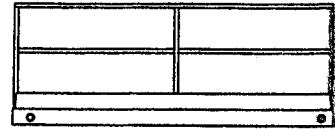

SECTION 11-4 PLATFORM

FIGURE & ITEM NO	PART NUMBER	DESCRIPTION	QTY.	REV.
11-4-1		STANDARD HANDRAILS AND ACCESSORIES INSTALLATION	Ref.	
		PLATFORM OPTIONS:		
	3510264	Platform - All CM2033 Built Prior to April 1992	1	
	3510369	Platform - CM2033 With Fixed Deck Built April 1992 to Present	1	
	3510367	Platform - CM2033 With Extendable Deck Built April 1992 to Present	1	
	3510313	Platform - All CM2046 and CM2546 Built Prior to April 1992	1	
	3510370	Platform - CM2046 and CM2546 With Fixed Deck Built April 1992 to Present	1	
	3510404	Platform - CM2046 and CM2546 With Fixed Deck and Optional Tread Grip Floor	1	
	3510368	Platform - CM2046 and CM2546 With Extendable Deck Built April 1992 to Present	1	
	3510403	Platform - CM2046 and CM2546 With Extendable Deck and Optional Tread Grip Floor	1	
	3510314	Platform - All CM2558 Built Prior to April 1993	1	
	3510416	Platform - CM2558 With Fixed Deck Built April 1993 to Present	1	
	3510417	Platform - CM2558 With Extendable Deck Built April 1993 to Present	1	
	3510420	Platform - CM2558 With Extendable Deck and Optional Tread Grip Floor	1	
	3510418	Platform - CM2558 With Extendable Deck and Optional Tread Grip Floor and Harness Rings	1	
		STANDARD HANDRAILS INSTALLATION (STANDARD PARTS)	Ref.	
-1	3640727	Handrail - Right Side	1	
-2	3640728	Handrail - Left Side	1	
-3	Not Used			
-4	1260136	Chain	2 ft./61m	
-5	3010088	Link	2	
-6	2940064	Snap-Hook	1	
-7	0641424	Bolt 1/4"-20NC x 3"	A/R	
-8	4711400	Flatwasher 1/4" Narrow	A/R	
-9	4761400	Lockwasher 1/4"	A/R	
-10	3311401	Nut 1/4"-20NC	A/R	
-11	Not Used			
-12	3520072	Plug, Cap	6	
-13	3300373	Nut, Joint Connector 1 1/4"	4	
-14	3900184	Screw, Button Head #10-24NC x 5/8"	12	
-15	3300375	Nut, Joint Connector 2 3/8"	4	
	0251303	STANDARD HANDRAILS INSTALLATION (CM2033 WITH FIXED DECK - NOT SHOWN) (VARIABLE PARTS)	Ref.	F
-51	4565201	Tube, Handrail - Rear	1	
-52	3534682	Kickplate - Front	1	

SECTION 11-4 PLATFORM



SECTION 11-4 PLATFORM

FIGURE & ITEM NO	PART NUMBER	DESCRIPTION	QTY.	REV.
11-4-1		STANDARD HANDRAILS AND ACCESSORIES INSTALLATION		
-53	Not Required			
-54	Not Required			
-55	Not Required			
-56	Not Used			
-57	3640796	Tube, Handrail - Front	1	
	0251304	STANDARD HANDRAILS INSTALLATION (CM2033 WITH EXTENDABLE DECK - NOT SHOWN) (VARIABLE PARTS)	Ref.	E
-51	4565201	Tube, Handrail - Rear	1	
-52	Not Required			
-53	Not Required			
-54	Not Required			
-55	Not Required			
-56	Not Used			
-57	Not Required			
	0251392	STANDARD HANDRAIL INSTALLATION (CM2046 AND CM2546 WITH FIXED DECK) (VARIABLE PARTS)	Ref.	F
-51	4565202	Tube, Handrail - Rear	1	
-52	3534740	Kickplate - Front	1	
-53	3640713	Tube, Handrail - Rear Vertical	2	
-54	3534742	Kickplate - Rear	2	
-55	0641408	Bolt 1/4"-20NC x 1"	4	
-56	Not Used			
-57	4564731	Tube, Handrail - Front	2	
	0251393	STANDARD HANDRAIL INSTALLATION (CM2046 AND CM2546 WITH EXTENDABLE DECK) (VARIABLE PARTS)	Ref.	F
-51	4565202	Tube, Handrail - Rear	1	
-52	Not Required			
-53	3640713	Tube, Handrail - Rear Vertical	2	
-54	3534742	Kickplate - Rear	2	
-55	0641408	Bolt 1/4"-20NC x 1"	4	
-56	Not Used			
-57	Not Required			
	0251394	STANDARD HANDRAIL INSTALLATION (CM2558 WITH FIXED DECK) (VARIABLE PARTS)	Ref.	F
-51	4565203	Tube, Handrail - Rear	1	
-52	3534741	Kickplate - Front	1	
-53	3640713	Tube, Handrail - Rear Vertical	2	
-54	3534743	Kickplate - Rear	2	
-55	0641408	Bolt 1/4"-20NC x 1"	4	
-56	Not Used			
-57	4564732	Tube, Handrail	2	

SECTION 11-4 PLATFORM

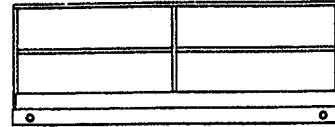
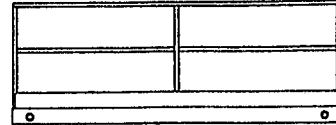

FIGURE & ITEM NO	PART NUMBER	DESCRIPTION	QTY.	REV.
11-4-1		STANDARD HANDRAILS AND ACCESSORIES INSTALLATION (CONTINUED)	Ref.	
	0251395	STANDARD HANDRAIL INSTALLATION (CM2558 WITH EXTENDABLE DECK) (VARIABLE PARTS)	Ref.	F
-51	4565203	Tube, Handrail - Rear	1	
-52	Not Required			
-53	3640713	Tube, Handrail - Rear Vertical	2	
-54	3534743	Kickplate - Rear	2	
-55	0641408	Bolt 1/4"-20NC x 1"	4	
-56	Not Used			
-57	Not Required			
	1281573	OPTIONAL RECEPTACLE INSTALLATION (STANDARD PARTS WHEN EQUIPPED)	Ref.	B
-101	0860038	Box, Electrical	1	
-102	Not Used			
-103	Not Used			
-104	4460051	Connector, Strain Relief	1	
-105	0960407	Bushing, Reducer	1	
-106	0721004	Bolt #10-24NC x 1/2"	4	
-107	4751000	Flatwasher #10	4	
-108	4761000	Lockwasher #10	4	
-109	1320061	Clamp	10	
-110	4761400	Lockwasher 1/4"	8	
-111	3311401	Nut 1/4"-20NC	8	
-112	4300032	Stud (Welded on Part)	8	
-113	Not Used			
-114	1060308	Cable, Electrical - 12/3 CM2033 and CM2046 CM2546 and CM2558	A/R 42 ft./13m 45 ft./14m	
-115	1700598	Decal - Wire Marker (Ground)	2	
-116	1700599	Decal - Wire Marker (Neutral)	2	
	0251759	OPTIONAL 110 VOLT RECEPTACLE INSTALLATION - STANDARD RECEPTACLE (CM2033) (VARIABLE PARTS)	Ref.	D
	0251778	OPTIONAL 110 VOLT RECEPTACLE INSTALLATION - STANDARD RECEPTACLE (CM2046) (VARIABLE PARTS)	Ref.	D
	0251780	OPTIONAL 110 VOLT RECEPTACLE INSTALLATION - STANDARD RECEPTACLE (CM2546 AND CM2558) (VARIABLE PARTS)	Ref.	D
-151	Not Used			
-152	4460190	Receptacle, Standard	1	
-153	4060092	Shield, Cover	1	
-154	4460138	Plug	1	

SECTION 11 - 4 PLATFORM

SECTION 11-4 PLATFORM



SECTION 11-4 PLATFORM

FIGURE & ITEM NO	PART NUMBER	DESCRIPTION	QTY.	REV.
11-4-1		STANDARD HANDRAILS AND ACCESSORIES INSTALLATION (CONTINUED)	Ref.	
	0251777	OPTIONAL 110 VOLT RECEPTACLE INSTALLATION - GROUND FAULT INTERRUPT RECEPTACLE (CM2033) (VARIABLE PARTS)	Ref.	D
	0251779	OPTIONAL 110 VOLT RECEPTACLE INSTALLATION - GROUND FAULT INTERRUPT RECEPTACLE (CM2046) (VARIABLE PARTS)	Ref.	D
	0251781	OPTIONAL 110 VOLT RECEPTACLE INSTALLATION- GROUND FAULT INTERRUPT RECEPTACLE (CM2546 AND CM2558) (VARIABLE PARTS)	Ref.	D
-151	Not Used			
-152	4460346	Receptacle, Ground Fault Interrupt	1	
-153	4060700	Shield, Cover	1	
-154	4460205	Plug	1	
	0252714	OPTIONAL 110 VOLT RECEPTACLE INSTALLATION - U/L APPROVED RECEPTACLE (CM2033) (VARIABLE PARTS)	Ref.	—
	0252715	OPTIONAL 110 VOLT RECEPTACLE INSTALLATION - U/L APPROVED RECEPTACLE (CM2046) (VARIABLE PARTS)	Ref.	—
	0252716	OPTIONAL 110 VOLT RECEPTACLE INSTALLATION - U/L APPROVED RECEPTACLE (CM2546 AND CM2558) (VARIABLE PARTS)	Ref.	—
-151	Not Used			
-152	4460347	Receptacle, U/L Approved	1	
-153	4060092	Shield, Cover	1	
-154	4460138	Plug	1	
	0254378	OPTIONAL 220 VOLT RECEPTACLE INSTALLATION - (CM2033 AND CM2046) (VARIABLE PARTS)	Ref.	A
	0254379	OPTIONAL 220 VOLT RECEPTACLE INSTALLATION - (CM2546 AND CM2558) (VARIABLE PARTS)	Ref.	A
-151	Not Used			
-152	Supply Locally	Receptacle, Standard	1	
-153	4060092	Shield, Cover	1	
	1281952	OPTIONAL ROTATING BEACON LIGHT INSTALLATION (STANDARD PARTS WHEN EQUIPPED)	Ref.	A
-201	0901546	Bracket	1	
-202	0641414	Bolt 1/4"-20NC x 1 3/4"	2	
-203	4751400	Flatwasher 1/4"	2	
-204	3311505	Locknut 1/4"-20NC	2	

SECTION 11-4 PLATFORM

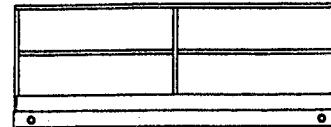

FIGURE & ITEM NO	PART NUMBER	DESCRIPTION	QTY.	REV.
------------------	-------------	-------------	------	------

11-4-1		STANDARD HANDRAILS AND ACCESSORIES INSTALLATION (CONTINUED)	Ref.	
	0253476	OPTIONAL ROTATING BEACON LIGHT INSTALLATION - CM2033/2046 (VARIABLE PARTS)	Ref.	—
	0253477	OPTIONAL ROTATING BEACON LIGHT INSTALLATION - CM2033/2046 (U/L) (VARIABLE PARTS)	Ref.	—
	0253478	OPTIONAL ROTATING BEACON LIGHT INSTALLATION - CM2546/2558 (VARIABLE PARTS)	Ref.	—
	0253479	OPTIONAL ROTATING BEACON LIGHT INSTALLATION - CM2546/2558 (U/L) (VARIABLE PARTS)	Ref.	—
—251	2920087	Light, Beacon - Standard	1	
	2920092	Light, Beacon - U/L Approved (Not Shown)	1	
	0253504	OPTIONAL WORKLIGHTS INSTALLATION - CM2033/2046 (VARIABLE PARTS)	Ref.	—
	0253505	OPTIONAL WORKLIGHTS INSTALLATION - CM2033/2046 (U/L) (VARIABLE PARTS)	Ref.	—
	0253506	OPTIONAL WORKLIGHTS INSTALLATION - CM2546/2558 (VARIABLE PARTS)	Ref.	—
	0253507	OPTIONAL WORKLIGHTS INSTALLATION - CM2546/2558 (U/L) (VARIABLE PARTS)	Ref.	—
—301	2920088	Worklight (Standard Machines Built Prior to August 1992)	2	
	2920093	Worklight (Standard Machines Built August 1992 to Present and All U/L Approved Machines)	2	
	0253544	OPTIONAL HARNESS ATTACH RINGS INSTALLATION	Ref.	—
—401	3534309	Plate, Ring Attach	2	
—402	3760274	Ring, Lanyard	2	

SECTION 11 - 4 PLATFORM

SECTION 11-4 PLATFORM

FIGURE 11-4-2. OPTIONAL FOLD-DOWN HANDRAIL INSTALLATIONS.

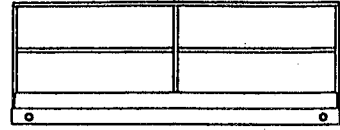

SECTION 11-4 PLATFORM

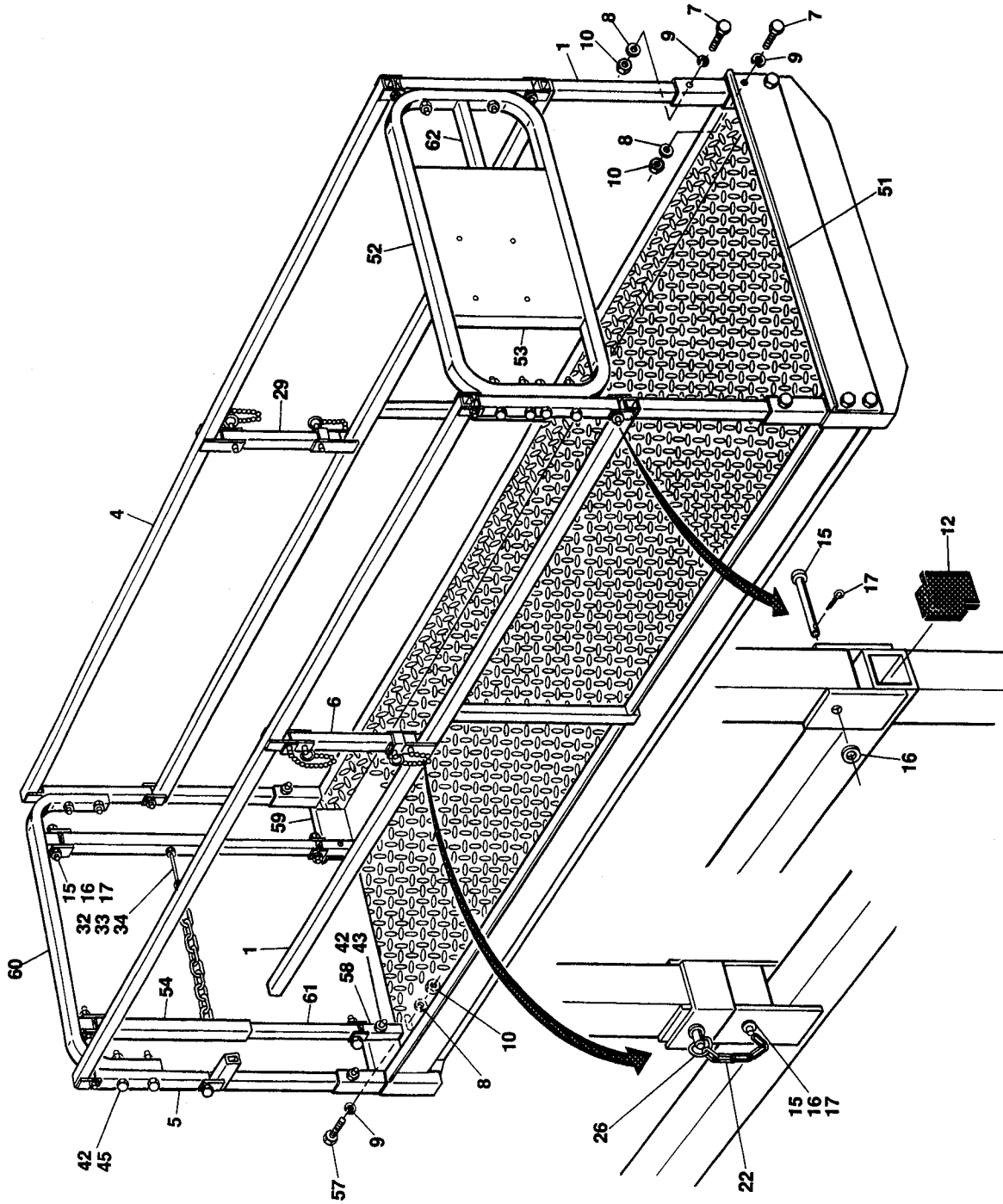

SECTION 11-4 PLATFORM

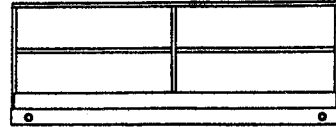

SECTION 11 - 4 PLATFORM

FIGURE & ITEM NO	PART NUMBER	DESCRIPTION	QTY.	REV.
11-4-2		OPTIONAL FOLD-DOWN HANDRAIL INSTALLATIONS	Ref.	
		FOLD-DOWN HANDRAIL INSTALLATION - ALL DECKS (STANDARD PARTS WHEN EQUIPPED)	Ref.	
-1	3640738	Handrail - Lower Side	2	
-2	Not Used			
-3	Not Used			
-4	3640740	Handrail - Top Side	2	
-5	4565191	Tube - Ends	4	
-6	3640742	Tube - Center (Right Side)	1	
-7	0641424	Bolt 1/4"-20NC x 3"	A/R	
-8	4751400	Flatwasher 1/4"	A/R	
-9	4761400	Lockwasher 1/4"	A/R	
-10	3311401	Nut 1/4"-20NC	A/R	
-11	Not Used			
-12	3520072	Plug, Cap	22	
-13	Not Used			
-14	Not Used			
-15	3430416	Pin, Clevis 1/4" x 2"	16	
-16	4711400	Flatwasher 1/4"	42	
-17	3450203	Pin, Cotter 1/16" x 3/4"	16	
-18	Not Used			
-19	Not Used			
-20	Not Used			
-21	Not Used			
-22	1260017	Chain (4 Lengths 7 in./17.8 cm each)	28 in./7m	
-23	Not Used			
-24	Not Used			
-25	Not Used			
-26	3421913	Pin, Quick Release	4	
-27	Not Used			
-28	Not Used			
-29	3640753	Tube - Center (Left Side)	1	
-30	Not Used			
-31	Not Used			
-32	1260136	Chain	2.5 ft./8m	
-33	3010088	Link	2	
-34	2700056	Snap-Hook	1	
-35 to -41	Not Used			
-42	3900184	Screw, Button Head #10-24NC x 5/8"	10	
-43	3300373	Nut, Joint Connector 1 1/4"	6	
-44	Not Used			
-45	3300375	Nut, Joint Connector 2 3/8"	4	
	0252680	FOLD-DOWN HANDRAIL INSTALLATION - CM2033 WITH FIXED DECK (VARIABLE PARTS)	Ref.	C
-51	3534682	Kickplate - Front	1	
-52	4564730	Handrail - Front	2	
-53	3533091	Plate, Mounting - Control Box	1	
-54	Not Required			
-55	Not Used			
-56	Not Used			
-57	Not Required			

SECTION 11-4 PLATFORM

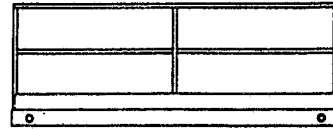

SECTION 11-4 PLATFORM

FIGURE & ITEM NO	PART NUMBER	DESCRIPTION	QTY.	REV.
11-4-2		OPTIONAL FOLD-DOWN HANDRAIL INSTALLATIONS (CONTINUED)	Ref.	
-58	Not Required			
-59	Not Required			
-60	4565285	Handrail - Rear	1	
-61	Not Required			
-62	Not Required			
	0252681	FOLD-DOWN HANDRAIL INSTALLATION - CM2033 WITH EXTENDABLE DECK (VARIABLE PARTS)	Ref.	C
-51	Not Required			
-52	Not Required			
-53	Not Required			
-54	Not Required			
-55	Not Used			
-56	Not Used			
-57	Not Required			
-58	Not Required			
-59	Not Required			
-60	4565285	Handrail - Rear	1	
-61	Not Required			
-62	Not Required			
	0252676	FOLD-DOWN HANDRAIL INSTALLATION - CM2046 AND CM2546 WITH FIXED DECK (VARIABLE PARTS)	Ref.	B
-51	3534740	Kickplate - Front	1	
-52	4564731	Handrail - Front	2	
-53	3533091	Plate, Mounting - Control Box	1	
-54	3640743	Handrail - Top Rear Vertical	2	
-55	Not Used			
-56	Not Used			
-57	0641408	Bolt 1/4"-20NC x 1"	4	
-58	3640761	Handrail - Bottom Rear Vertical	2	
-59	3535337	Kickplate - Rear	2	
-60	3640744	Handrail - Rear	1	
-61	4565261	Handrail - Center Rear Vertical	2	
-62	4565598	Tube, Support	1	
	0252677	FOLD-DOWN HANDRAIL INSTALLATION - CM2046 AND CM2546 WITH EXTENDABLE DECK (VARIABLE PARTS)	Ref.	B
-51	Not Required			
-52	Not Required			
-53	Not Required			
-54	3640743	Handrail - Top Rear Vertical	2	
-55	Not Used			

SECTION 11-4 PLATFORM

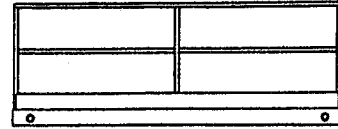

SECTION 11-4 PLATFORM

FIGURE & ITEM NO	PART NUMBER	DESCRIPTION	QTY.	REV.
11-4-2		OPTIONAL FOLD-DOWN HANDRAIL INSTALLATIONS (CONTINUED)	Ref.	
-56	Not Used			
-57	0641408	Bolt 1/4"-20NC x 1"	4	
-58	3640761	Handrail - Bottom Rear Vertical	2	
-59	3535337	Kickplate - Rear	2	
-60	3640744	Handrail - Rear	1	
-61	4565261	Handrail - Center Rear Vertical	2	
-62	Not Required			
	0252678	FOLD-DOWN HANDRAIL INSTALLATION - CM2558 WITH FIXED DECK (VARIABLE PARTS)	Ref.	B
-51	3534741	Kickplate - Front	1	
-52	4564732	Handrail - Front	2	
-53	3533091	Plate, Mounting - Control Box	1	
-54	3640743	Handrail - Top Rear Vertical	2	
-55	Not Used			
-56	Not Used			
-57	0641408	Bolt 1/4"-20NC x 1"	4	
-58	3640761	Handrail - Bottom Rear Vertical	2	
-59	3535492	Kickplate - Rear	2	
-60	3640745	Handrail - Rear	1	
-61	4565261	Handrail - Center Rear Vertical	2	
-62	4565599	Tube, Support	1	
	0252679	FOLD-DOWN HANDRAIL INSTALLATION - CM2558 WITH EXTENDABLE DECK (VARIABLE PARTS)	Ref.	B
-51	Not Required			
-52	Not Required			
-53	Not Required			
-54	3640743	Handrail - Top Rear Vertical	2	
-55	Not Used			
-56	Not Used			
-57	0641408	Bolt 1/4"-20NC x 1"	4	
-58	3640761	Handrail - Bottom Rear Vertical	2	
-59	3535492	Kickplate - Rear	2	
-60	3640745	Handrail - Rear	1	
-61	4565261	Handrail - Center Rear Vertical	2	
-62	Not Required			

SECTION 11-4 PLATFORM

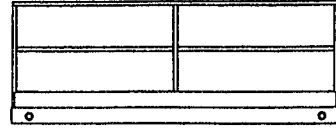
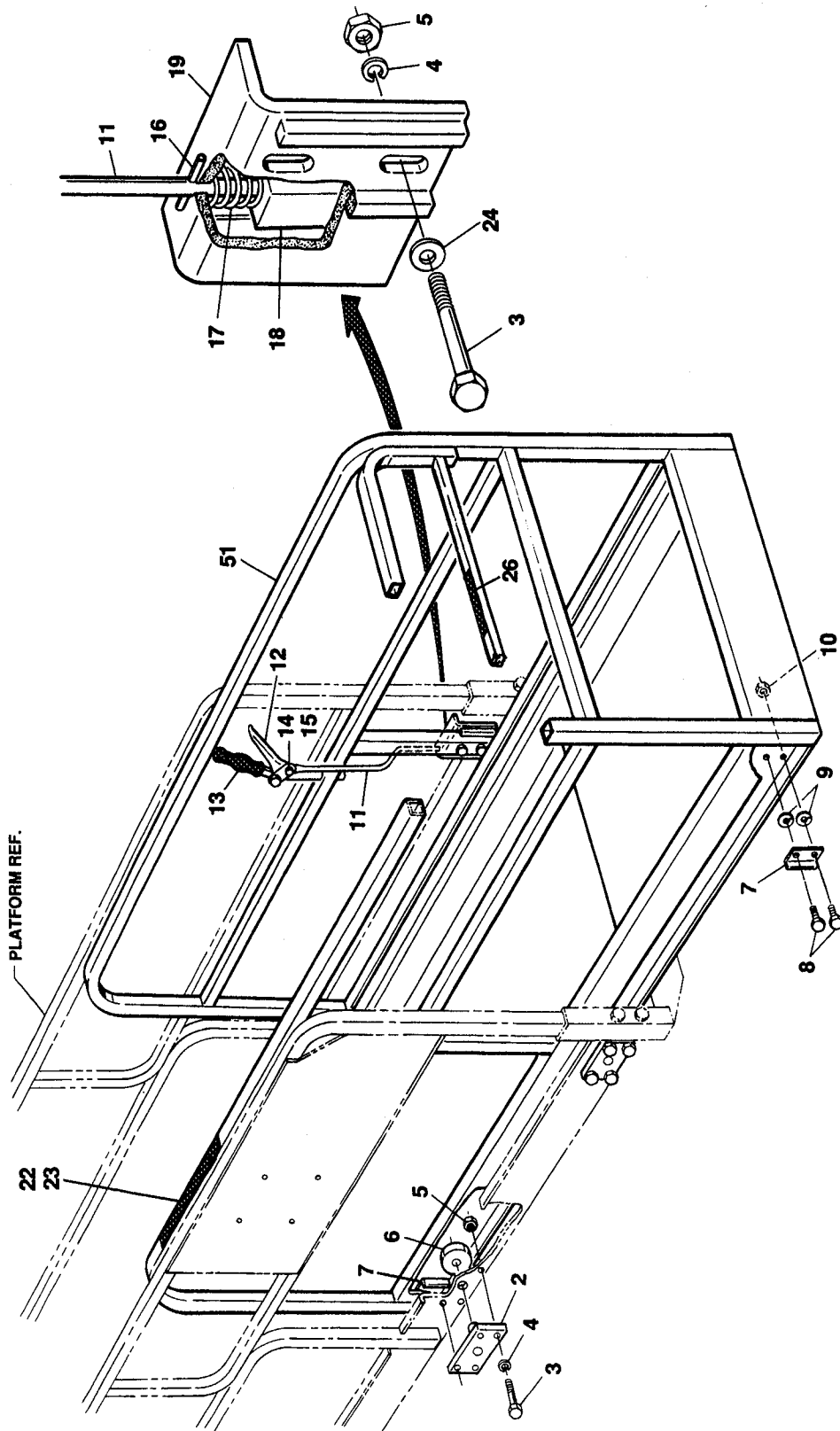
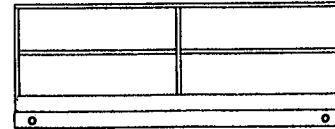

FIGURE 11-4-3. OPTIONAL EXTENDABLE DECK INSTALLATION WITH STANDARD HANDRAILS.

SECTION 11-4 PLATFORM



SECTION 11-4 PLATFORM



SECTION 11-4 PLATFORM

FIGURE & ITEM NO	PART NUMBER	DESCRIPTION	QTY.	REV.
11-4-3		OPTIONAL EXTENDABLE DECK INSTALLATION WITH STANDARD HANDRAILS	Ref.	
	1281415	EXTENDABLE DECK INSTALLATION (STANDARD PARTS WHEN EQUIPPED)	Ref.	E
-1	Not Used			
-2	4843706	Mounting Weldment - Roller	4	
-3	0641508	Bolt 5/16"-18NC x 1"	16	
-4	4761500	Lockwasher 5/16"	18	
-5	3311501	Nut 5/16"-18NC	16	
-6	3860052	Roller	4	
	4712200	Shim, Flatwasher (Steel)	A/R	
	4740066	Shim, Flatwasher (Thin Bronze)	A/R	
-7	0181684	Angle, Stop	4	
-8	0641408	Bolt 1/4"-20NC x 1"	8	
-9	4761400	Lockwasher 1/4"	12	
-10	3311401	Nut 1/4"-20NC	8	
-11	3841074	Rod, Release	1	
-12	2980113	Release Lever Assembly	1	
-13	2560088	Grip, Handle	1	
-14	0641406	Bolt 1/4"-20NC x 3/4"	1	
-15	3311405	Locknut 1/4"-20NC	1	
-16	3440413	Rollpin 1/8" x 13/16"	2	
-17	4160078	Spring	1	
-18	0361912	Bar, Latch	1	
-19	2940061	Latch Weldment	1	
-20	Not Used			
-21	Not Used			
-22	3251852	Nameplate - Capacity	1	
-23	3820001	Rivet	2	
-24	4751500	Flatwasher 5/16"	4	
-25	0641516	Bolt 5/16"-18NC x 2"	2	
-26	3252136	Nameplate - Control Box Location	1	
	0251202	EXTENDABLE DECK INSTALLATION (CM2033) (VARIABLE PARTS)	Ref.	E
	0253536	EXTENDABLE DECK INSTALLATION (CM2033 S/N 7861 AND 7862) (VARIABLE PARTS)	Ref.	—
	0251249	EXTENDABLE DECK INSTALLATION (CM2046/2546) (VARIABLE PARTS)	Ref.	
	0251250	EXTENDABLE DECK INSTALLATION (CM2558) (VARIABLE PARTS)	Ref.	
-51		EXTENDABLE PLATFORM DECK OPTIONS:		
	3510489	Extendable Platform Deck (CM2033)	1	
	3510396	Extendable Platform Deck (CM2033 S/N 7861 and 7862)	1	
	3510316	Extendable Platform Deck (CM2046 and CM2546)	1	
	3510317	Extendable Platform Deck (CM2558)	1	

SECTION 11-4 PLATFORM

FIGURE 11-4-4. OPTIONAL EXTENDABLE DECK INSTALLATION WITH FOLD-DOWN HANDRAILS.

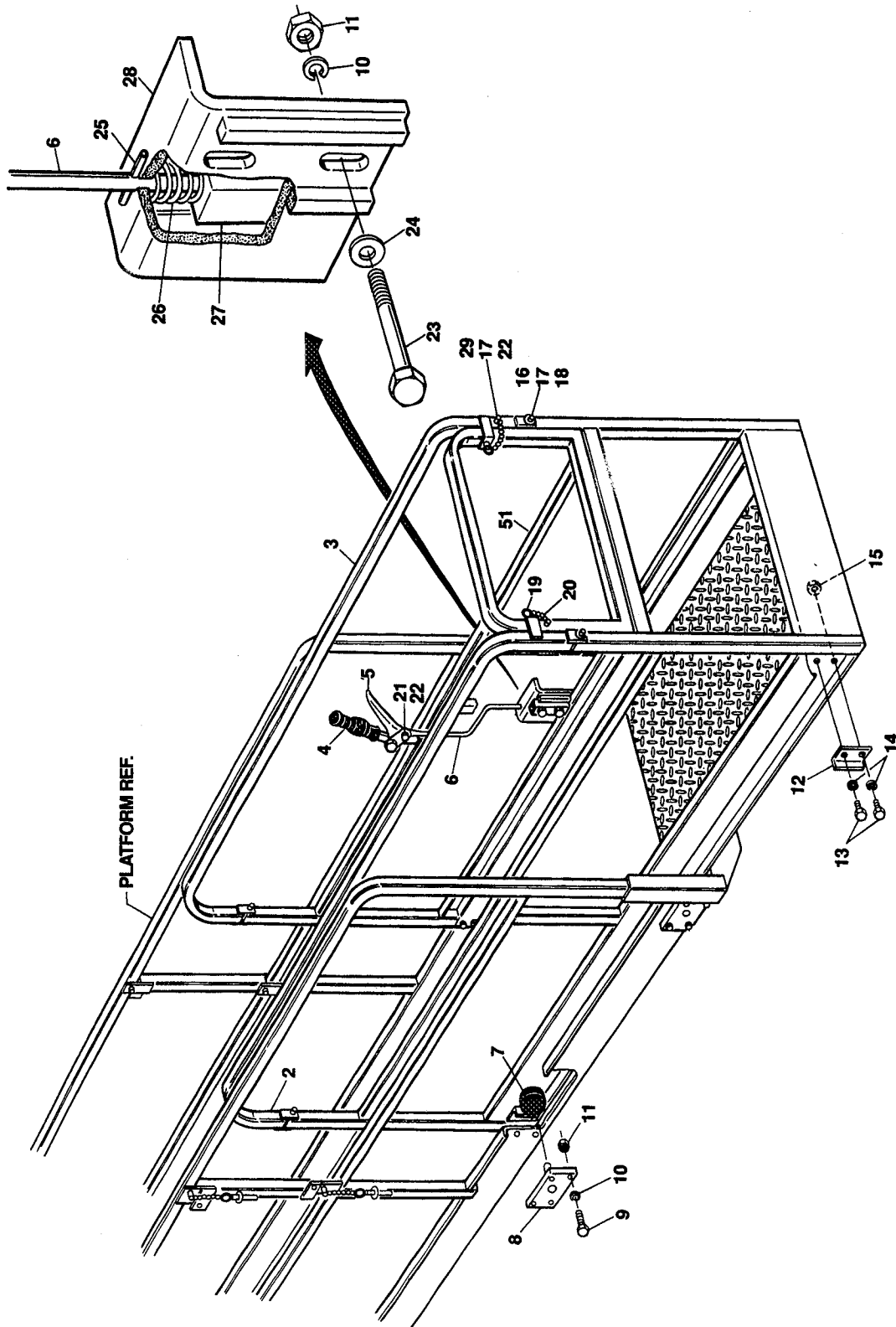
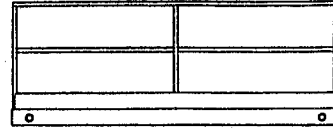

SECTION 11-4 PLATFORM

SECTION 11-4 PLATFORM

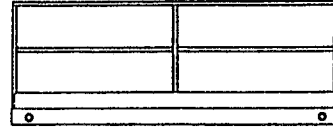

SECTION 11-4 PLATFORM

FIGURE & ITEM NO	PART NUMBER	DESCRIPTION	QTY.	REV.
11-4-4		OPTIONAL EXTENDABLE DECK INSTALLATION WITH FOLD-DOWN HANDRAILS	Ref.	
	1281617	EXTENDABLE DECK INSTALLATION (STANDARD PARTS WHEN EQUIPPED)	Ref.	C
-1	Not Used			
-2	3640749	Handrail - Right Side	1	
-3	3640748	Handrail - Left Side	1	
-4	2560088	Grip, Handle	1	
-5	2980113	Release Lever Assembly	1	
-6	3841201	Rod, Release	1	
-7	3860052	Roller	4	
	4712200	Shim, Flatwasher (Steel)	A/R	
	4740066	Shim, Flatwasher (Thin Bronze)	A/R	
-8	4843706	Mounting Weldment - Roller	4	
-9	0641510	Bolt 5/16"-18NC x 1 1/4"	16	
-10	4761500	Lockwasher 5/16"	18	
-11	3311501	Nut 5/16"-18NC	18	
-12	0181684	Angle	4	
-13	0641406	Bolt 1/4"-20NC x 3/4"	8	
-14	4761400	Lockwasher 1/4"	12	
-15	3311401	Nut 1/4"-20NC	8	
-16	3430416	Pin, Clevis 1/4" x 2"	4	
-17	4711400	Flatwasher 1/4" Narrow	12	
-18	3450203	Pin, Cotter 1/16" x 3/4"	4	
-19	3421913	Pin, Quick Release	2	
-20	1260017	Chain (2 Lengths 7 in./17.8 Each)	14 in./35.6cm	
-21	0641406	Bolt 1/4"-20NC x 3/4"	1	
-22	3311405	Locknut 1/4"-20NC	3	
-23	0641516	Bolt 5/16"-18NC x 2"	2	
-24	4751500	Flatwasher 5/16"	4	
-25	3440413	Rollpin 1/8" x 13/16"	2	
-26	4160078	Spring	1	
-27	0361912	Bar, Latch	1	
-28	2940061	Latch Weldment	1	
-29	0641416	Bolt 1/4"-20NC x 2"	2	
	0253383	EXTENDABLE DECK INSTALLATION (VARIABLE PARTS)	Ref.	A
	0253391	EXTENDABLE DECK INSTALLATION (CM2046/2546) (VARIABLE PARTS)	Ref.	—
	0253392	EXTENDABLE DECK INSTALLATION (CM2558) (VARIABLE PARTS)	Ref.	—
-51		PLATFORM DECK WELDMENT OPTIONS:		
	3510494	Platform Deck Weldment (CM2033)	1	
	3510391	Platform Deck Weldment (CM2046 and CM2546)	1	
	3510392	Platform Deck Weldment (CM2558 Standard Floor)	1	
	3510419	Platform Deck Weldment (CM2558 With Tread Grip Floor)	1	

SECTION 11-4 PLATFORM

FIGURE 11-4-5. OPTIONAL HYDRAULICALLY EXTENDED DECK INSTALLATION, WITH STANDARD HANDRAILS.

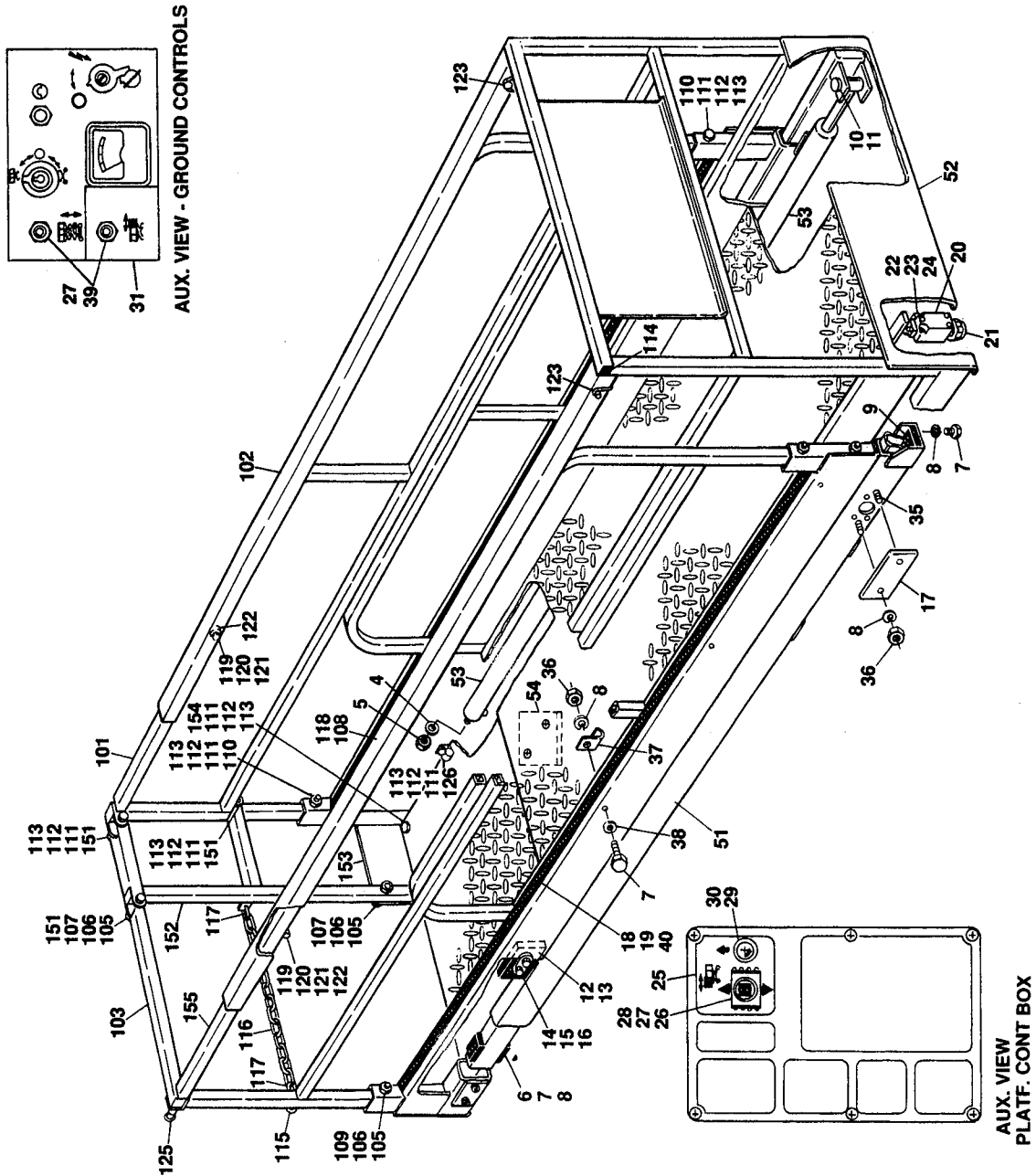
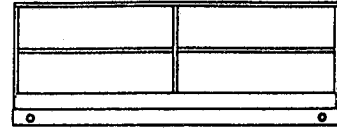

SECTION 11-4-11 PLATFORM

SECTION 11-4 PLATFORM

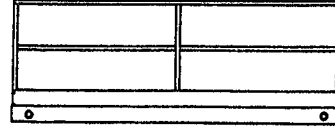

SECTION 11-4 PLATFORM

FIGURE & ITEM NO	PART NUMBER	DESCRIPTION	QTY.	REV.
11-4-5		OPTIONAL HYDRAULICALLY EXTENDED DECK INSTALLATION WITH STANDARD HANDRAILS	Ref.	
	1282216	HYDRAULICALLY EXTENDED DECK INSTALLATION (STANDARD PARTS)	Ref.	E
-1	Not Used			
-2	Not Used			
-3	Not Used			
-4	4712200	Flatwasher 3/4" Narrow	2	
-5	3322205	Locknut 3/4"-16NF	2	
-6	3340710	Pad, Slide	4	
-7	0641606	Bolt 3/8"-16NC x 3/4"	8	
-8	4761600	Lockwasher 3/8"	8	
-9	3340711	Pad, Wear	2	
-10	3431220	Pin, Clevis 3/4" x 2 1/2"	2	
-11	3450406	Pin, Cotter 1/8" x 3/4"	2	
-12	4240017	Strap, Tie	4	
-13	3340716	Block, Slide	2	
-14	0641614	Bolt 3/8"-16NC x 1 3/4"	4	
-15	4711600	Flatwasher 3/8" Narrow	8	
-16	3311605	Locknut 3/8"-16NC	4	
-17	3538344	Plate	6	
-18	4280292	Strip, Rubber	2	
-19	3820030	Rivet	14	
-20	4360322	Switch, Limit	1	
-21	4460428	Connector, Strain Relief	1	
-22	3911020	Screw #10-24NC x 1 1/4"	2	
-23	4751000	Flatwasher #10	2	
-24	3311005	Locknut #10-24NC	2	
-25	1702366	Decal - Platform Extension	1	
-26	4360314	Switch, Toggle	1	
-27	3790012	O-Ring	2	
-28	4060802	Shield, Switch	1	
-29	2920094	Bulb, Light	1	
-30	2920026	Lamp, Indicator - Red	1	
-31	1702370	Decal - Platform Extension	1	
-32	Not Used			
-33	Not Used			
-34	Not Used			
-35	4300031	Stud (Welded on Part)	12	
-36	3311401	Nut 1/4"-20NC	17	
-37	1320061	Clamp	5	
-38	4751400	Flatwasher 1/4"	5	
-39	4360202	Switch, Toggle	2	
-40	0362420	Bar, Aluminum	2	
	0254868	HYDRAULICALLY EXTENDED DECK INSTALLATION - 4 FT. DECK (CM2033) (VARIABLE PARTS)	Ref.	C
-51	3510462	Platform Weldment	1	
-52	3510463	Extension Deck Weldment	1	
-53	1683204	Extension Cylinder Assembly (See Section 11-5 for Breakdown)	1	
-54	Not Required			

SECTION 11-4 PLATFORM

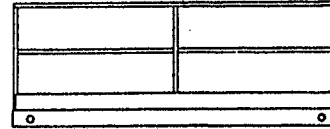

SECTION 11-4 PLATFORM

FIGURE & ITEM NO	PART NUMBER	DESCRIPTION	QTY.	REV.
11-4-5		OPTIONAL HYDRAULICALLY EXTENDED DECK INSTALLATION WITH STD HANDRAILS (CONTINUED)	Ref.	
	0254794	HYDRAULICALLY EXTENDED DECK INSTALLATION - 6 FT. DECK (CM2033) (VARIABLE PARTS)	Ref.	C
-51	3510462	Platform Weldment	1	
-52	3510463	Extension Deck Weldment	1	
-53	1683199	Extension Cylinder Assembly (See Section 11-5 for Breakdown)	1	
-54	Not Required			
	0255228	HYDRAULICALLY EXTENDED DECK INSTALLATION - 4 FT. DECK (CM2046) (VARIABLE PARTS)	Ref.	A
-51	3510469	Platform Weldment	1	
-52	3510470	Extension Deck Weldment	1	
-53	1683204	Extension Cylinder Assembly (See Section 11-5 for Breakdown)	1	
-54	3340749	Pad, Wear	1	
	3911612	Screw, Machine 3/8"-16NC x 3/4"	2	
	0100019	Loctite #271	A/R	
	0255229	HYDRAULICALLY EXTENDED DECK INSTALLATION - 6 FT. DECK (CM2046) (VARIABLE PARTS)	Ref.	A
-51	3510469	Platform Weldment	1	
-52	3510470	Extension Deck Weldment	1	
-53	1683199	Extension Cylinder Assembly (See Section 11-5 for Breakdown)	1	
-54	3340749	Pad, Wear	1	
	3911612	Screw, Machine 3/8"-16NC x 3/4"	2	
	0100019	Loctite #271	A/R	
	0254957	HYDRAULICALLY EXTENDED DECK INSTALLATION - 4 FT. DECK (CM2546) (VARIABLE PARTS)	Ref.	D
-51	3510469	Platform Weldment	1	
-52	3510470	Extension Deck Weldment	1	
-53	1683204	Extension Cylinder Assembly (See Section 11-5 for Breakdown)	1	
-54	3340749	Pad, Wear	1	
	3911612	Screw, Machine 3/8"-16NC x 3/4"	2	
	0100019	Loctite #271	A/R	
	0254958	HYDRAULICALLY EXTENDED DECK INSTALLATION - 6 FT. DECK (CM2546) (VARIABLE PARTS)	Ref.	D
-51	3510469	Platform Weldment	1	
-52	3510470	Extension Deck Weldment	1	
-53	1683199	Extension Cylinder Assembly (See Section 11-5 for Breakdown)	1	
-54	3340749	Pad, Wear	1	
	3911612	Screw, Machine 3/8"-16NC x 3/4"	2	
	0100019	Loctite #271	A/R	
	0255054	HYDRAULICALLY EXTENDED DECK INSTALLATION - 4 FT. DECK (CM2558) (VARIABLE PARTS)	Ref.	B
-51	3510484	Platform Weldment	1	
-52	3510485	Extension Deck Weldment	1	

SECTION 11-4 PLATFORM

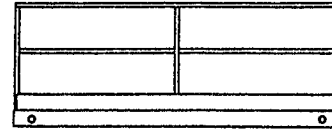

SECTION 11-4 PLATFORM

FIGURE & ITEM NO	PART NUMBER	DESCRIPTION	QTY.	REV.
11-4-5		OPTIONAL HYDRAULICALLY EXTENDED DECK INSTALLATION WITH STD HANDRAILS (CONTINUED)	Ref.	
—53	1683204	Extension Cylinder Assembly (See Section 11-5 for Breakdown)	1	
—54	3340749	Pad, Wear	1	
	3911612	Screw, Machine 3/8"-16NC x 3/4"	2	
	0100019	Loctite #271	A/R	
	0255055	HYDRAULICALLY EXTENDED DECK INSTALLATION - 6 FT. DECK (CM2558) (VARIABLE PARTS)	Ref.	B
—51	3510484	Platform Weldment	1	
—52	3510485	Extension Deck Weldment	1	
—53	1683199	Extension Cylinder Assembly (See Section 11-5 for Breakdown)	1	
—54	3340749	Pad, Wear	1	
	3911612	Screw, Machine 3/8"-16NC x 3/4"	2	
	0100019	Loctite #271	A/R	
		HANDRAILS INSTALLATION (STANDARD PARTS)	Ref.	
—101	4844793	Rail Weldment (Left Side)	1	
—102	3538042	Plate, Slide Rail	1	
—103	4844819	Rail Weldment (Top)	1	
—104	Not Used		1	
—105	3900184	Screw, Button Head	A/R	
—106	3300374	Nut, Joint Connector	A/R	
—107	4771000	Starwasher #10	5	
—108	3534821	Slide Rail Weldment	1	
—109	3300375	Nut, Joint Connector	A/R	
—110	0641424	Bolt 1/4"-20NC x 3"	A/R	
—111	4711400	Flatwasher 1/4" Narrow	A/R	
—112	4761400	Lockwasher 1/4"	A/R	
—113	3311401	Nut 1/4"-20NC	A/R	
—114	3520072	Cap, Plug	A/R	
—115	2940064	Hook, Snap	1	
—116	1260136	Chain	2 Ft.	
—117	3010088	Link	2	
—118	4420055	Tape	1 Ft.	
—119	0641409	Bolt 1/4"-20NC x 1 1/8"	2	
—120	4740234	Washer, Thrust	A/R	
—121	3311405	Locknut 1/4"-20NC	4	
—122	0961906	Bushing	2	
—123	3421453	Pin, Snap (All except CM2033)	2	
	3422219	Pin, Snap (CM2033)	2	
—124	Not Used			
—125	3422369	Pin, Plunger	1	
—126	1320202	Clamp	2	
	0254797	HANDRAILS INSTALLATION - CM2033	Ref.	C
—151 to—154	Not Required			
—155	4844821	Rail Weldment (Right Side)	1	

SECTION 11-4 PLATFORM

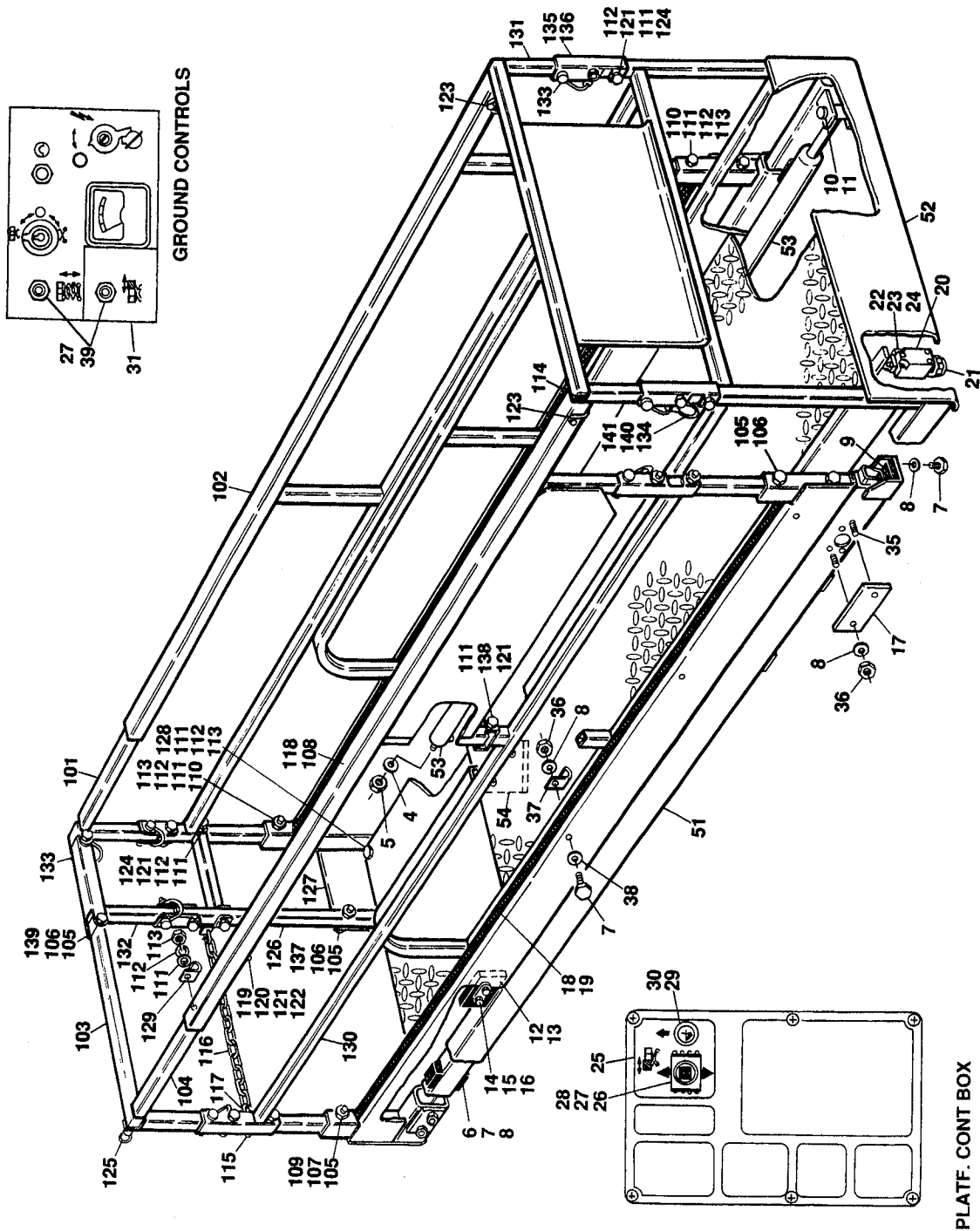
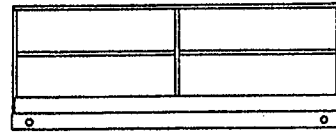

FIGURE & ITEM NO	PART NUMBER	DESCRIPTION	QTY.	REV.
11-4-5		OPTIONAL HYDRAULICALLY EXTENDED DECK INSTALLATION (CONTINUED)	Ref.	
	0254973	HANDRAILS INSTALLATION - CM2046 AND CM2546	Ref.	A
-151	0641416	Bolt 1/4"-20NC x 2"	2	
-152	4844831	Rail Weldment (Rear)	1	
-153	3538217	Kickplate (Rear)	1	
-154	0641408	Bolt 1/4"-20NC x 1"	2	
-155	4844792	Rail Weldment (Right Side)	1	
	0255063	HANDRAILS INSTALLATION - CM2558	Ref.	—
-151	0641416	Bolt 1/4"-20NC x 2"	2	
-152	4844831	Rail Weldment (Rear Left Side)	1	
	4844854	Rail Weldment (Rear Right Side - Not Shown)	1	
-153	3538217	Kickplate (Rear)	2	
-154	0641408	Bolt 1/4"-20NC x 1"	2	
-155	4844853	Rail Weldment (Right Side)	1	

SECTION 11-4 PLATFORM

SECTION 11-4 PLATFORM

FIGURE 11-4-5A. OPTIONAL HYDRAULICALLY EXTENDED DECK INSTALLATION, WITH FOLD-DOWN HANDRAILS.



SECTION 11-4 PLATFORM

SECTION 11-4 PLATFORM



SECTION 11-4 PLATFORM

FIGURE & ITEM NO	PART NUMBER	DESCRIPTION	QTY.	REV.
11-4-5A		OPTIONAL HYDRAULICALLY EXTENDED DECK INSTALLATION WITH FOLDDOWNHANDRAILS	Ref.	
	1282216	HYDRAULICALLY EXTENDED DECK INSTALLATION (STANDARD PARTS)	Ref.	E
-1	Not Used			
-2	Not Used			
-3	Not Used			
-4	4712200	Flatwasher 3/4" Narrow	2	
-5	3322205	Locknut 3/4"-16NF	2	
-6	3340710	Pad, Slide	4	
-7	0641406	Bolt 1/4"-20NC x 3/4"	8	
-8	4761400	Lockwasher 1/4"	8	
-9	3340711	Pad, Wear	2	
-10	3431220	Pin, Clevis 3/4" x 2 1/2"	2	
-11	3450406	Pin, Cotter 1/8" x 3/4"	2	
-12	4240017	Strap, Tie	4	
-13	3340716	Block, Slide	2	
-14	0641614	Bolt 3/8"-16NC x 1 3/4"	4	
-15	4711600	Flatwasher 3/8" Narrow	8	
-16	3311605	Locknut 3/8"-16NC	4	
-17	3538344	Plate	6	
-18	4280292	Strip, Rubber	2	
-19	3820030	Rivet	14	
-20	4360322	Switch, Limit	1	
-21	4460428	Connector, Strain Relief	1	
-22	3911020	Screw #10-24NC x 1 1/4"	2	
-23	4751000	Flatwasher #10	2	
-24	3311005	Locknut #10-24NC	2	
-25	1702366	Decal - Platform Extension	1	
-26	4360314	Switch, Toggle	1	
-27	3790012	O-Ring	2	
-28	4060802	Shield, Switch	1	
-29	2920094	Bulb, Light	1	
-30	2920026	Lamp, Indicator - Red	1	
-31	1702370	Decal - Platform Extension	1	
-32	Not Used			
-33	Not Used			
-34	Not Used			
-35	4300031	Stud (Welded on Part)	12	
-36	3311401	Nut 1/4"-20NC	17	
-37	1320061	Clamp	5	
-38	4751400	Flatwasher 1/4"	5	
-39	4360202	Switch, Toggle	2	
-40	0362420	Bar, Aluminum	2	
	0255161	HYDRAULICALLY EXTENDED DECK INSTALLATION - 4 FT. DECK (CM2546) (VARIABLE PARTS)	Ref.	A
-51	3510469	Platform Weldment	1	
-52	3510487	Extension Deck Weldment	1	
-53	1683204	Extension Cylinder Assembly (See Section 11-5 for Breakdown)	1	
-54	3340749	Pad, Wear	1	
	3911612	Screw, Machine 3/8"-16NC x 3/4"	2	
	0100019	Loctite #271	A/R	

SECTION 11-4 PLATFORM

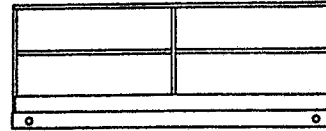
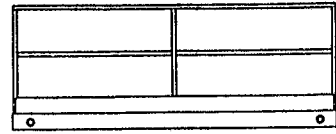

FIGURE & ITEM NO	PART NUMBER	DESCRIPTION	QTY.	REV.
11-4-5A		OPTIONAL HYDRAULICALLY EXTENDED DECK INSTALLATION WITH FOLDDOWNHANDRAILS (CONTINUED)	Ref.	
	0255162	HYDRAULICALLY EXTENDED DECK INSTALLATION - 6 FT. DECK (CM2546) (VARIABLE PARTS)	Ref.	A
-51	3510469	Platform Weldment	1	
-52	3510487	Extension Deck Weldment	1	
-53	1683199	Extension Cylinder Assembly (See Section 11-5 for Breakdown)	1	
-54	3340749	Pad, Wear	1	
	3911612	Screw, Machine 3/8"-16NC x 3/4"	2	
	0100019	Loctite #271	A/R	
	0255157	HANDRAILS INSTALLATION	Ref.	B
-101	4844908	Rail (Left Side Top)	1	
-102	3538042	Slide (Left Side Top)	1	
-103	4844819	Rail (Rear Top)	1	
-104	4844906	Rail (Right Side Top)	1	
-105	3900184	Screw, Button Head	4	
-106	3300374	Nut, Joint Connector	4	
-107	Not Used			
-108	4844821	Slide (Right Side Top)	1	
-109	3300375	Nut, Joint Connector	3	
-110	0641424	Bolt 1/4"-20NC x 3"	6	
-111	4711400	Flatwasher 1/4" Narrow	59	
-112	4751400	Flatwasher 1/4" Regular	25	
-113	Not Used			
-114	3520072	Cap, Plastic	11	
-115	2940064	Snap-Hook	1	
-116	1260136	Chain	2 ft./6m	
-117	3010088	Link	2	
-118	4420055	Tape	1 ft./3m	
-119	0641409	Bolt 1/4"-20NC x 1 1/8"	2	
-120	4740234	Washer, Thrust	8	
-121	3311405	Locknut 1/4"-20NC	24	
-122	0961906	Bushing	2	
-123	3421453	Snap-Pin	7	
-124	0641416	Bolt 1/4"-20NC x 2"	2	
-125	3422369	Pin, Plunger	1	
-126	4844912	Rail, Vertical (Lower Rear)	1	
-127	3538217	Kickplate (Rear)	1	
-128	0641408	Bolt 1/4"-20NC x 1"	2	
-129	1320202	Clamp	2	
-130	4844907	Rail, Slide (Both Side Bottom)	2	
-131	4844909	Rail Weldment (Front)	1	
-132	4844913	Rail, Vertical (Upper Rear)	1	
-133	3422219	Snap-Pin	3	
-134	1060379	Cable, Lanyard	7	
-135	4200010	Hinge, Stamped	7	
-136	4280284	Strip	2 ft./6m	
-137	3300373	Nut, Joint Connector	1	
-138	0641422	Bolt 1/4"-20NC x 2 3/4"	2	
-139	4751500	Flatwasher 5/16"	2	
-140	3760170	Ring, Quick Release	10	
-141	3941404	Screw, Self-Tapping 1/4" x 1/2"	3	

SECTION 11-4 PLATFORM

SECTION 11-4 PLATFORM

FIGURE 11-4-6. STEEL PLATFORM CONSOLE BOX ASSEMBLY.



SECTION 11-4 PLATFORM

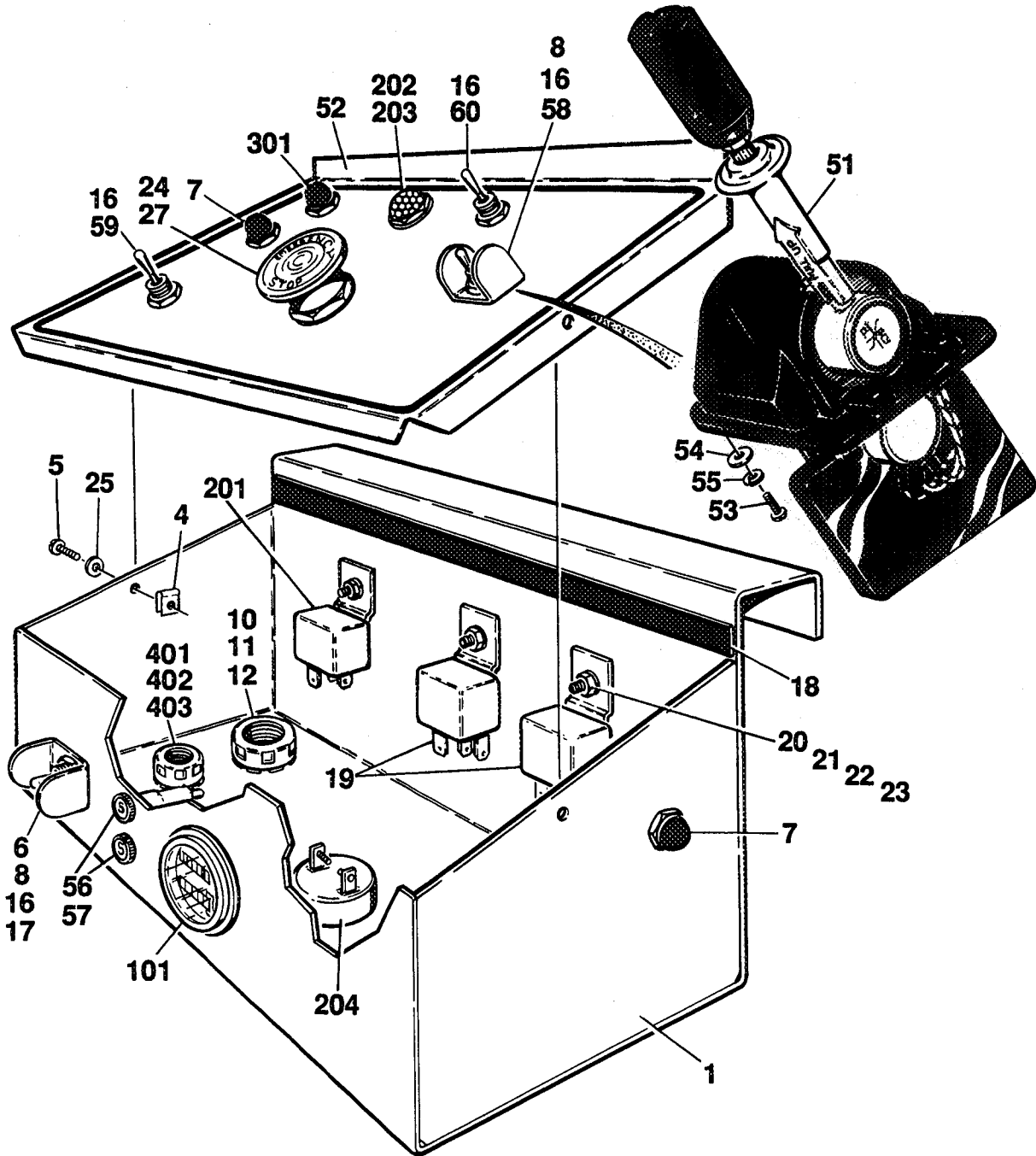

SECTION 11-4 PLATFORM

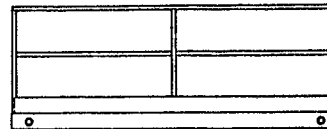
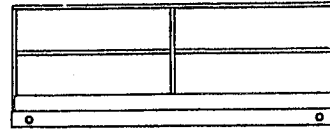

FIGURE & ITEM NO	PART NUMBER	DESCRIPTION	QTY.	REV.
11-4-6		STEEL PLATFORM CONSOLE BOX ASSEMBLY	Ref.	
		CONSOLE BOX ASSEMBLY (STANDARD PARTS)	Ref.	
—1	3534838	Box	1	
—2	Not Used			
—3	Not Used			
—4	3300177	Nut, Tinnerman	2	
—5	0751006	Screw, Machine #10 x 3/4"	2	
—6	4360202	Switch, Toggle - DPDT/MC/CO (Lift)	1	
—7	4360274	Switch, Push Button - SPST (Posi Trac)	1	
—8	4060229	Shield, Switch	A/R	
—9	Not Used			
—10	4460051	Connector, Strain Relief	1	
—11	3300048	Locknut, Conduit	1	
—12	0960238	Bushing	1	
—13	Not Used			
—14	Not Used			
—15	Not Used			
—16	3790012	O-Ring	A/R	
—17	3251860	Nametag - Lift	1	
—18	4420008	Tape, Insulation	32 in./8m	
—19	3740069	Relay, Power	2	
—20	3910608	Screw, Machine #6 x 1/2"	2	
—21	4760600	Lockwasher #6	2	
—22	4750600	Flatwasher #6	2	
—23	3310601	Nut #6-32NC	2	
—24	4360289	Switch, Push-Pull (Emergency Stop)	1	
—25	4740120	Washer, Nylon	2	
—26	Not Used			
—27	0100035	Loctite #222	A/R	
	0251505	CONSOLE BOX ASSEMBLY (WITH TOGGLE SWITCH DRIVE - STANDARD) (VARIABLE PARTS)	Ref.	E
	0252768	CONSOLE BOX ASSEMBLY (WITH TOGGLE SWITCH DRIVE - U/L APPROVED) (VARIABLE PARTS)	Ref.	—
—51	Not Required			
—52	3252065	Lid, Control Box	1	
—53	Not Required			
—54	Not Required			
—55	Not Required			
—56	Not Required			
—57	Not Required			
—58	4360202	Switch, Toggle - DPDT/MC/CO (Drive)	1	
—59	4360198	Switch, Toggle - SPDT/MC/CO (Steer)	1	
—60	4360092	Switch, Toggle - (Drive Speed)	1	

SECTION 11 - 4 PLATFORM

SECTION 11-4 PLATFORM



SECTION 11-4 PLATFORM

FIGURE & ITEM NO	PART NUMBER	DESCRIPTION	QTY.	REV.
11-4-6		STEEL PLATFORM CONSOLE BOX ASSEMBLY (CONTINUED)	Ref.	
	0251513	CONSOLE BOX ASSEMBLY (WITH PQ CONTROLLER/ BANG-BANG DRIVE - STANDARD) (VARIABLE PARTS)	Ref.	E
-51	1600132	Controller, PQ	1	
-52	3252067	Lid, Control Box	1	
-53	0720803	Screw, Machine #8 x 3/8"	4	
-54	4750800	Flatwasher #8	4	
-55	4760800	Lockwasher #8	4	
-56	Not Required			
-57	Not Required			
-58	Not Required			
-59	Not Required			
-60	Not Required			
	0252659	CONSOLE BOX ASSEMBLY (WITH PQ CONTROLLER/ BANG-BANG DRIVE - U/L APPROVED) (VARIABLE PARTS)	Ref.	A
-51	1600132	Controller, PQ	1	
-52	3252067	Lid, Control Box	1	
-53	0720803	Screw, Machine #8 x 3/8"	4	
-54	4750800	Flatwasher #8	4	
-55	4760800	Lockwasher #8	4	
-56	2400021	Fuseholder	2	
-57	2400026	Fuse	2	
-58	Not Required			
-59	Not Required			
-60	Not Required			
	0252420	CONSOLE BOX ASSEMBLY (WITH PQ CONTROLLER/ PROPORTIONAL DRIVE - STANDARD) (VARIABLE PARTS)	Ref.	—
-51	1600143	Controller, PQ	1	
-52	3252067	Lid, Control Box	1	
-53	0720803	Screw, Machine #8 x 3/8"	4	
-54	4750800	Flatwasher #8	4	
-55	4760800	Lockwasher #8	4	
-56	Not Required			
-57	Not Required			
-58	Not Required			
-59	Not Required			
-60	Not Required			
	0252769	CONSOLE BOX ASSEMBLY (WITH PQ CONTROLLER/ PROPORTIONAL DRIVE - U/L APPROVED) (VARIABLE PARTS)	Ref.	—
-51	1600143	Controller, PQ	1	

SECTION 11-4 PLATFORM

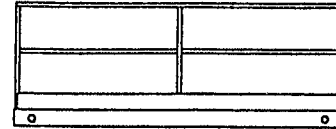

FIGURE & ITEM NO	PART NUMBER	DESCRIPTION	QTY.	REV.
11-4-6		STEEL PLATFORM CONSOLE BOX ASSEMBLY (CONTINUED)	Ref.	
-52	3252067	Lid, Control Box	1	
-53	0720803	Screw, Machine #8 x 3/8"	4	
-54	4750800	Flatwasher #8	4	
-55	4760800	Lockwasher #8	4	
-56	2400021	Fuseholder	2	
-57	2400026	Fuse	2	
	0251758	OPTIONAL BATTERY/HOUR GAUGE INSTALLATION	Ref.	B
-101	2420106	Gauge, Battery/Hour	1	
	0251724	OPTIONAL TILT INDICATOR INSTALLATION	Ref.	C
-201	3740069	Relay, Power	1	
-202	2920026	Light, Indicator - Red	1	
-203	2920094	Bulb, Light	1	
-204	0140011	Alarm, Sonalert	1	
	0251788	OPTIONAL HORN INSTALLATION	Ref.	B
-301	4360274	Switch, Push Button	1	
		OPTIONAL BEACON LIGHT INSTALLATION	Ref.	
-401	4460049	Connector, Strain Relief	1	
-402	0960239	Bushing	1	
-403	3300047	Locknut, Conduit	1	

SECTION 11-4 PLATFORM

SECTION 11-4 PLATFORM

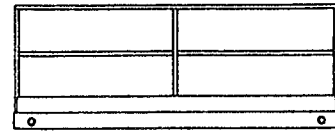
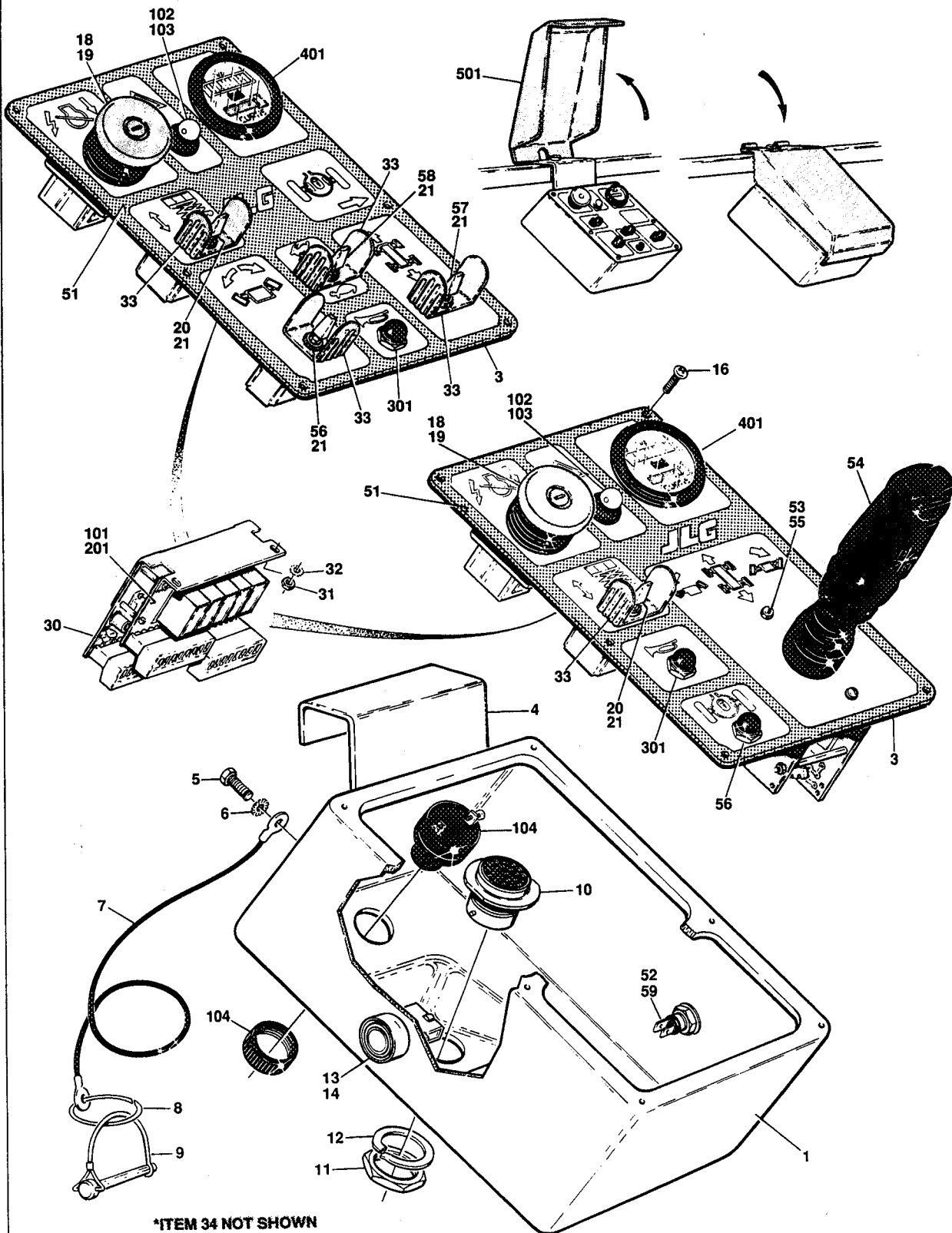

FIGURE 11-4-7. MOLDED PLATFORM CONSOLE BOX ASSEMBLY.



SECTION 11-4 PLATFORM

SECTION 11-4 PLATFORM

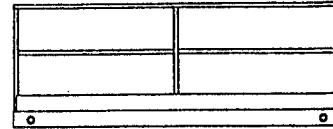
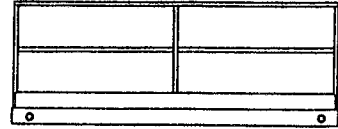

FIGURE & ITEM NO	PART NUMBER	DESCRIPTION	QTY.	REV.
11-4-7		MOLDED PLATFORM CONSOLE BOX ASSEMBLY	Ref.	
		CONSOLE BOX ASSEMBLY (STANDARD PARTS)	Ref.	
-1	0860784	Box, Console	1	
-2	Not Used			
-3	4420008	Tape, Insulation	32 in./8m	
-4	0901859	Bracket, Hanger	1	
-5	0641404	Bolt 1/4"-20NC x 1/2"	4	
-6	4791400	Starwasher 1/4"	4	
-7	1060380	Lanyard - 10"/25.4cm	1	
-8	3760170	Ring	1	
-9	3421453	Pin, Snapper	1	
-10	4460463	Receptacle, Terminal	1	
-11	4460470	Nut, Panel	1	
-12	4460471	Lockwasher	1	
-13	4360339	Switch, Push Button	1	
	7012593	Boot, Green Rubber	1	
-14	4360267	Switch, Contact - N.O.	1	
-15	Not Used			
-16	3900177	Screw	6	
-17	Not Used			
-18	4360289	Switch, Push/Pull (Emergency Stop)	1	
	7012611	Lens	1	
	7012612	Boot	1	
-19	0100035	Loctite#222	A/R	
-20	4360318	Switch, Toggle - DPDT/MC	1	
-21	3790012	O-Ring	A/R	
-22	Not Used			
-23	Not Used			
-24	Not Used			
-25	Not Used			
-26	Not Used			
-27	Not Used			
-28	Not Used			
-29	Not Used			
-30	0610101	Card, Circuit (RAM) (Prior to January 1995)	1	
	0610113	Card, Circuit (Jenesco) (January 1995 to Present)	1	
	0610110	Bracket, Mounting	1	
	7012658	Fuse - 7.5 Amp	1	
-31	3310601	Nut 36-32NC	2	
-32	4770600	Starwasher #6	A/R	
-33	4060802	Shield, Switch	1	
-34	1701827	Decal - Legend	1	
-35	Not Used			
-36	4740066	Washer, Thrust (Not Shown)	2	
	0253098	CONSOLE BOX ASSEMBLY (WITH TOGGLE SWITCH DRIVE - STANDARD)	Ref.	E
	0253400	CONSOLE BOX ASSEMBLY (WITH TOGGLE SWITCH DRIVE - UL APPROVED)	Ref.	D
-51	3252196	Lid, Control Box (Prior to January 1993)	1	
	3252253	Lid, Control Box (January 1993 to Present)	1	

SECTION 11 - 4 PLATFORM

SECTION 11-4 PLATFORM



SECTION 11-4 PLATFORM

FIGURE & ITEM NO	PART NUMBER	DESCRIPTION	QTY.	REV.
11-4-7		MOLDED PLATFORM CONSOLE BOX ASSEMBLY (CONTINUED)	Ref.	
—52	4360274	Switch, Push Button - SPST (Posi Trac)	1	
—53	Not Required			
—54	Not Required			
—55	Not Required			
—56	4360328	Switch, Toggle - SPST/MC/CO (Steer)	1	
—57	4360314	Switch, Toggle - DPDT/MC/CO (Drive)	1	
—58	4360345	Switch, Toggle - SPDT (Drive Speed) (2SPD - Prior to January 1993)	1	
	4360355	Switch, Toggle - DPDT (Drive Speed) (3SPD - January 1993 to Present)	1	
—59	Not Required			
	0253100	CONSOLE BOX ASSEMBLY (WITH PQ CONTROLLER/ BANG-BANG DRIVE - STANDARD)	Ref.	E
	0253403	CONSOLE BOX ASSEMBLY (WITH PQ CONTROLLER/ BANG-BANG DRIVE - U/L APPROVED)	Ref.	C
—51	3252194	Lid, Control Box	1	
—52	3520026	Plug, Hole	1	
—53	4740120	Washer, Nylon	2	
—54	1600156	Controller, PQ	1	
—55	3900178	Screw, Machine #10-32NF x 3/4"	2	
—56	4360274	Switch, Push Button - SPST (Posi-Trac)	1	
—57	Not Required			
—58	Not Required			
—59	0100009	Sealant, Silicon	A/R	
	2400021	Fuseholder (U/L Only)	2	
	2400026	Fuse (U/L Only)	2	
	0253404	CONSOLE BOX ASSEMBLY (WITH PQ CONTROLLER/ PROPORTIONAL DRIVE - STANDARD)	Ref.	E
	0253408	CONSOLE BOX ASSEMBLY (WITH PQ CONTROLLER/ PROPORTIONAL DRIVE - UL APPROVED)	Ref.	C
—51	3252194	Lid, Control Box	1	
—52	3520026	Plug, Hole	1	
—53	4740120	Washer, Nylon	2	
—54	1600160	Controller, PQ	1	
—55	3900178	Screw, Machine #10-32NF x 3/4"	2	
—56	4360274	Switch, Push Button - SPST (Posi-Trac)	1	
—57	Not Required			
—58	Not Required			
—59	0100009	Sealant, Silicon	A/R	
	2400021	Fuseholder (U/L Only)	2	
	2400026	Fuse (U/L Only)	2	

SECTION 11-4 PLATFORM

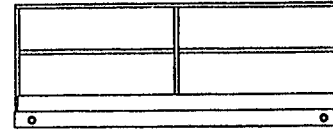

FIGURE & ITEM NO	PART NUMBER	DESCRIPTION	QTY.	REV.
11-4-7		MOLDED PLATFORM CONSOLE BOX ASSEMBLY (CONTINUED)	Ref.	
	0253485	OPTIONAL TILT INDICATOR INSTALLATION	Ref.	A
-101	0610105	Card, Circuit - Relay	1	
	0610110	Bracket, Mounting	1	
-102	2920094	Bulb, Light	1	
-103	2920026	Light, Indicator - Red	1	
-104	0140011	Alarm, Sonalert	1	
	0253491	OPTIONAL DRIVE CUT-OUT INSTALLATION	Ref.	A
-201	0610105	Card, Circuit - Relay	1	
	0610110	Bracket, Mounting	1	
	0253465	OPTIONAL HORN INSTALLATION	Ref.	-
-301	4360274	Switch, Push Button	1	
	4921537	Harness, Switch	1	
	0253499	OPTIONAL BATTERY/HOUR GAUGE INSTALLATION	Ref.	A
-401	2420106	Gauge, Battery/Hour	1	
	0253548	OPTIONAL CONSOLE BOX INSTALLATION	Ref.	-
-501	4844327	Cover	1	

SECTION 11-4 PLATFORM

SECTION 11-5

CYLINDERS

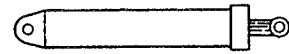

TABLE OF CONTENTS

FIGURE NO.	TITLE	PAGE NO.
11-5-1	Brake Cylinder Assembly (Prior to March 1992)	11-5-2
11-5-2	Brake Cylinder Assembly (March 1992 to Present)	11-5-4
11-5-3	Lift Cylinder Sub-Assembly	11-5-6
11-5-4	Platform Extension Cylinder Assembly (Hydraulically Extended Deck Option.	11-5-10
11-5-5	Steer Cylinder Assembly	11-5-12

SECTION 11-5
CYLINDERS

SECTION 11-5 CYLINDERS

FIGURE 11-5-1. BRAKE CYLINDER ASSEMBLY
(PRIOR TO MARCH 1992).

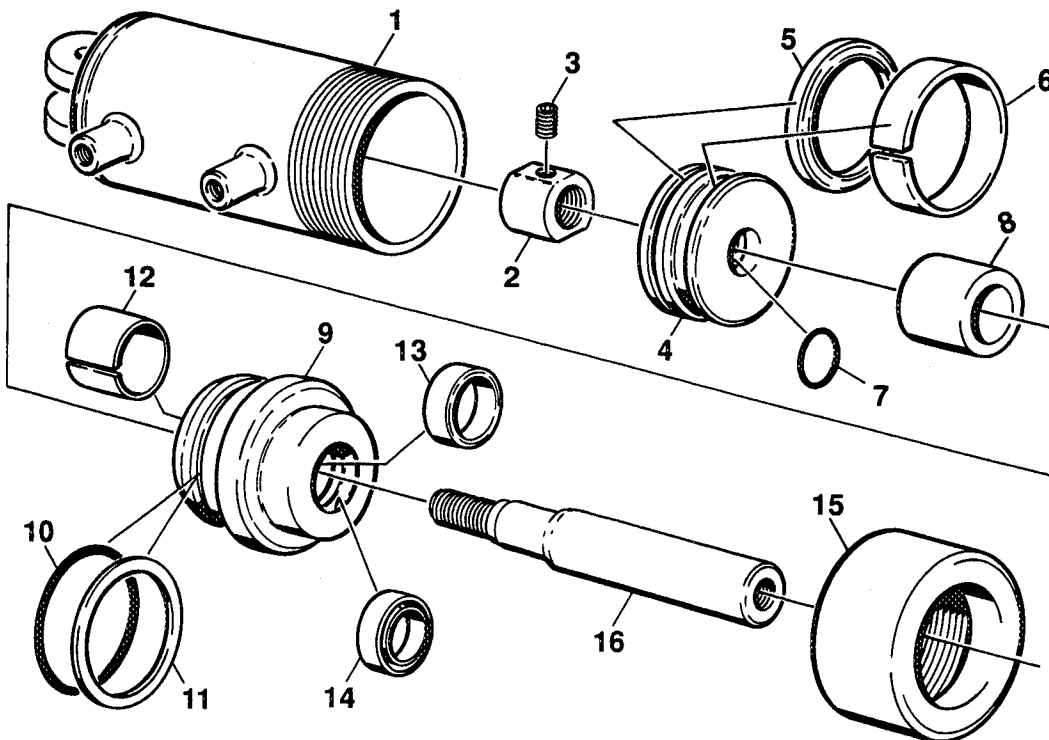
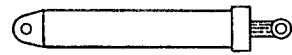

SECTION 11-5 CYLINDERS

SECTION 11-5 CYLINDERS

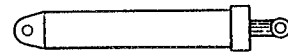
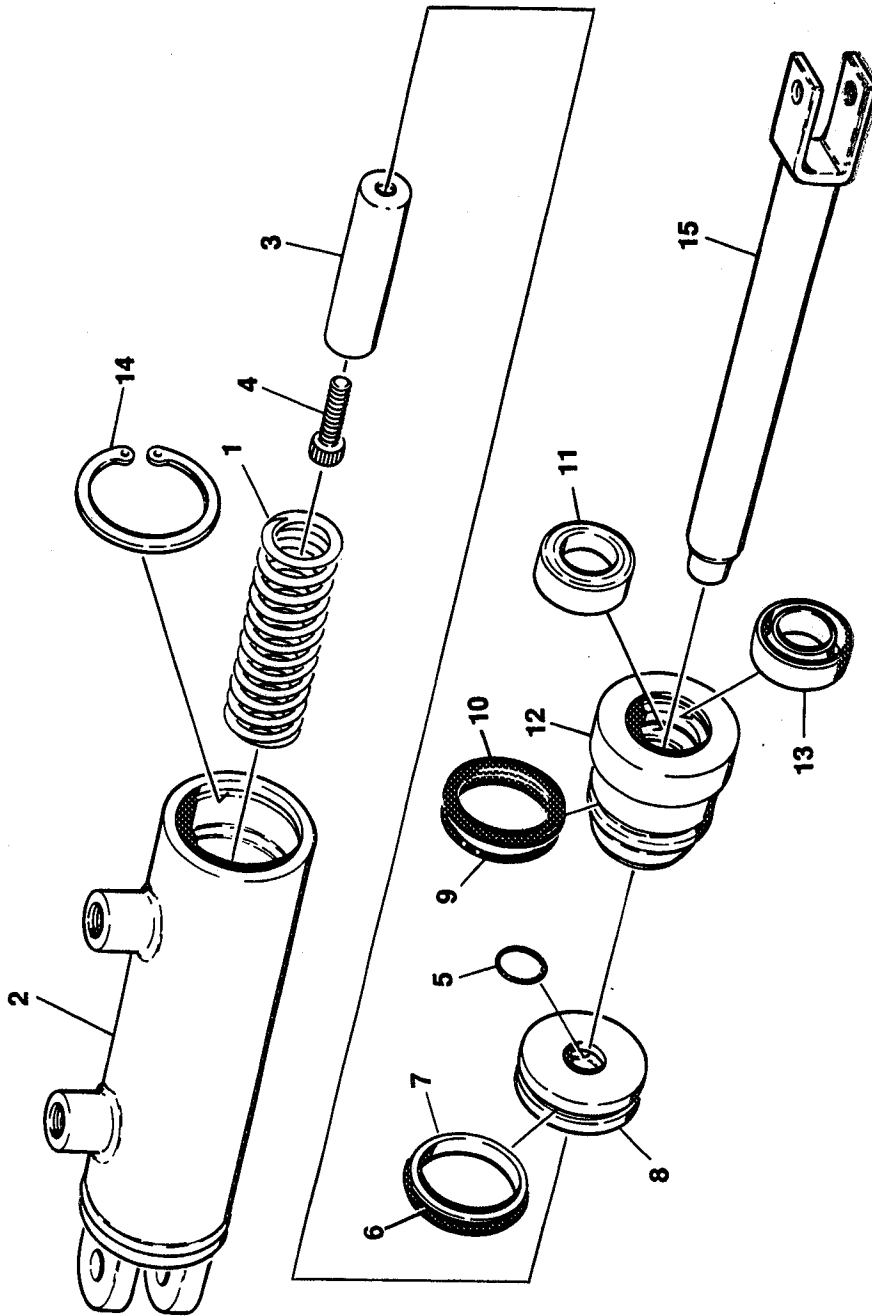

FIGURE & ITEM NO	PART NUMBER	DESCRIPTION	QTY.	REV.
11-5-1	1682445	BRAKE CYLINDER ASSEMBLY (PRIOR TO MARCH 1992)	Ref.	A
-1	1682446	Barrel	1	
-2	3300272	Nut	1	
	0100011	Loctite #242	A/R	
-3	3900170	Setscrew 3/8"-16NC x 3/8"	1	
-4	3480157	Piston	1	
-5	Kit	Seal, Piston	1	
-6	Kit	Ring, Wear	1	
-7	Kit	O-Ring	1	
-8	4565069	Tube, Spacer	1	
-9	1682449	Head	1	
-10	Kit	O-Ring	1	
-11	Kit	Ring, Back-Up	1	
-12	Kit	Ring, Wear	1	
-13	Kit	Seal, Rod	1	
-14	Kit	Wiper	1	
-15	1120083	Retainer	1	
	0100035	Loctite #222	A/R	
-16	1682448	Rod	1	
	2901187	Seal Kit (Includes Items 5,6,7,10,11,12,13 and 14)	1	

SECTION 11-5 CYLINDERS

SECTION 11-5 CYLINDERS

FIGURE 11-5-2. BRAKE CYLINDER ASSEMBLY
(MARCH 1992 TO PRESENT).



SECTION 11-5 CYLINDERS

SECTION 11-5 CYLINDERS



FIGURE & ITEM NO	PART NUMBER	DESCRIPTION	QTY.	REV.
11-5-2	1682277	BRAKE CYLINDER ASSEMBLY (MARCH 1992 TO DECEMBER 1993) Note: When replacing complete 1682277 cylinder recommend using 1683098 cylinder.	Ref.	—
	1683098	BRAKE CYLINDER ASSEMBLY (DECEMBER 1993 TO PRESENT)	Ref.	—
—1	7001093	Spring, Compression (1682277 Cylinder)	1	
	7001618	Spring, Compression (1683098 Cylinder)	1	
—2	Not Available	Barrel, Cylinder	1	
—3	7001094	Spacer	1	
—4	7001095	Bolt, Socket Head	1	
—5	Kit	O-Ring	1	
—6	Kit	Ring, Piston	1	
—7	Kit	O-Ring	1	
—8	7001096	Piston	1	
—9	Kit	O-Ring	1	
—10	Kit	Ring, Back-up	1	
—11	Kit	Seal	1	
—12	7001097	Head	1	
—13	Kit	Ring, Wiper	1	
—14	7001098	Ring, Retaining	1	
—15	7001099	Rod Weldment (1682277 Cylinder)	1	
	7001621	Rod Weldment (1683098 Cylinder)	1	
	7001092	Seal Kit (Includes Items 5,6,7,9,10,11 and 13)	1	

SECTION 11-5 CYLINDERS

SECTION 11-5 CYLINDERS

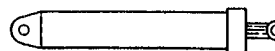
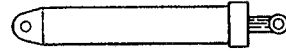

FIGURE & ITEM NO	PART NUMBER	DESCRIPTION	QTY.	REV.
11-5-3		LIFT CYLINDER SUB-ASSEMBLY	Ref.	
		VALVES AND CONTROLS INSTALLATION (STANDARD PARTS)	Ref.	
-1	4761500	Lockwasher 5/16"	2	
-2	0641506	Bolt 5/16"-18NC x 3/4"	2	
-3	0080190	Adapter	1	
-4	0901757	Bracket, Cable	1	
-5	1060377	Cable Assembly	1	
-6	3760170	D-Ring	1	
-7	3321402	Nut, Jam 1/4"-28NF	4	
-8	4751400	Flatwasher 1/4"	2	
-9	3311402	Nut, Jam 1/4"-20NC	1	
-10	3841127	Rod, Handle	1	
-11	3450405	Pin, Cotter	1	
-12	4220044	Stop, Throttle	1	
-13	2160002	Fitting, Grease	2	
		VALVES AND CONTROLS INSTALLATION - STANDARD MACHINES (VARIABLE PARTS)	Ref.	
-51	4640381	Cartridge, Valve - Solenoid Holding	1	
	7004334	Coil - 24VDC (Modular Controls Version)	1	
	7000644	Coil - 24VDC (Hydraforce Version)	1	
	2900503	Seal Kit (Modular Controls Version)	1	
	2900756	Seal Kit (Hydraforce Version)	1	
-52	4640688	Cartridge, Valve - Manual Pull Control (Prior to August 1991)	1	
	4640717	Cartridge, Valve - Manual Pull Control (August 1991 to Present)	1	
		VALVES AND CONTROLS INSTALLATION - U/L APPROVED MACHINES (VARIABLE PARTS)	Ref.	
-51	4640612	Cartridge, Valve - Solenoid Holding (24VDC)	1	
	4640804	Cartridge, Valve - Solenoid Holding (16VDC)	1	
	7010517	Coil - 24VDC	1	
	7010551	Coil - 16VDC	1	
	7010507	Shell, Coil	1	
	2900503	Seal Kit	1	
-52	4640717	Cartridge, Valve - Manual Pull Control	1	
		LIFT CYLINDER ASSEMBLY - CM2033 AND CM2046 (STANDARD PARTS)	Ref.	
-101	1682288	Rod Weldment	1	
	0961520	Bushing, Bronze	1	
-102	1120108	Cap, End	1	
-103	1681283	Head	1	
-104	3480147	Piston	1	

SECTION 11-5 CYLINDERS

SECTION 11-5 CYLINDERS



SECTION 11-5 CYLINDERS

FIGURE & ITEM NO	PART NUMBER	DESCRIPTION	QTY.	REV.
11-5-3		LIFT CYLINDER SUB-ASSEMBLY (CONTINUED)	Ref.	
-105	2200221	Plug, Pipe	3	
-106	Kit	Seal, Wiper	1	
-107	Kit	Seal, Rod	1	
-108	Kit	Ring, Wear	1	
-109	Kit	O-Ring	1	
-110	Kit	O-Ring	1	
-111	Kit	Seal, Piston	1	
-112	Kit	Ring, Guidelock	1	
-113	4564885	Tube, Spacer	1	
	0100011	Loctite #242	A/R	
	0100020	Sealant, Pipe	A/R	
	0100035	Loctite #222	A/R	
	0100038	Primer, Locking	A/R	
	2901165	Seal Kit (Includes Items 106-112)	1	
	1682302	LIFT CYLINDER ASSEMBLY - CM2033 AND CM2046 BUILT PRIOR TO MARCH 1991 (VARIABLE PARTS)	Ref.	B
		Note: When replacing complete cylinder assembly recommend using P/N 1682501.		
-151	1682301	Barrel Weldment	1	
	0961519	Bushing, Bronze	1	
-152	3300267	Nut (Not Shown)	1	
-153	3951404	Setscrew 1/4"-20NC x 1/2"	2	
-154	2180764	Plug	1	
-155	3421891	Pin	1	
-156	Not Required			
	1682501	LIFT CYLINDER ASSEMBLY - CM2033 AND CM2046 BUILT MARCH 1991 TO PRESENT (VARIABLE PARTS)	Ref.	B
-151	1682502	Barrel Weldment	1	
	0961519	Bushing, Bronze	1	
-152	3300281	Nut, Hex	1	
-153	3900170	Setscrew 3/8"-16NC x 3/8"	1	
-154	Not Required			
-155	Not Required			
-156	2220343	Fitting, Straight	2	
		LIFT CYLINDER ASSEMBLY - CM2546 AND CM2558 (STANDARD PARTS)	Ref.	
-101	1682266	Rod Weldment	1	
	0961520	Bushing, Bronze	1	
-102	1120305	Cap, End	1	
-103	1681423	Head	1	

SECTION 11-5 CYLINDERS

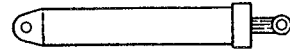

FIGURE & ITEM NO	PART NUMBER	DESCRIPTION	QTY.	REV.
11-5-3		LIFT CYLINDER SUB-ASSEMBLY (CONTINUED)		
-104	3480143	Piston	1	
-105	2200221	Plug, Pipe	4	
-106	Kit	Seal, Wiper	1	
-107	Kit	Seal, Rod	1	
-108	Kit	Ring, Wear	1	
-109	Kit	O-Ring	1	
-110	Kit	O-Ring	1	
-111	Kit	Seal, Piston	1	
-112	Kit	Ring, Guidelock	1	
-113	4565008	Tube, Spacer	1	
	0100011	Loctite #242	A/R	
	0100020	Sealant, Pipe	A/R	
	0100035	Loctite #222	A/R	
	0100038	Primer, Locking	A/R	
	2901158	Seal Kit (Includes Items 106-112)	1	
	1682417	LIFT CYLINDER ASSEMBLY - CM2546 AND CM2558 BUILT PRIOR TO MARCH 1991 (VARIABLE PARTS)	Ref.	B
		Note: When replacing complete cylinder assembly recommend using P/N 1682503.		
-151	1682264	Barrel Weldment	1	
	0961519	Bushing, Bronze	1	
-152	3300267	Nut (Not Shown)	1	
-153	3951404	Setscrew 1/4"-20NC x 1/2"	2	
-154	2180764	Plug	1	
-155	3421891	Pin	1	
-156	Not Required			
	1682503	LIFT CYLINDER ASSEMBLY - CM2546 AND CM2558 BUILT MARCH 1991 TO PRESENT (VARIABLE PARTS)	Ref.	D
-151	1682504	Barrel Weldment	1	
	0961519	Bushing, Bronze	1	
-152	3300281	Nut, Hex	1	
-153	3900170	Setscrew 3/8"-16NC x 3/8"	1	
-154	Not Required			
-155	Not Required			
-156	2220343	Fitting, Straight	2	

SECTION 11 - 5 CYLINDERS

SECTION 11-5 CYLINDERS

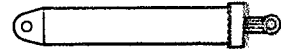
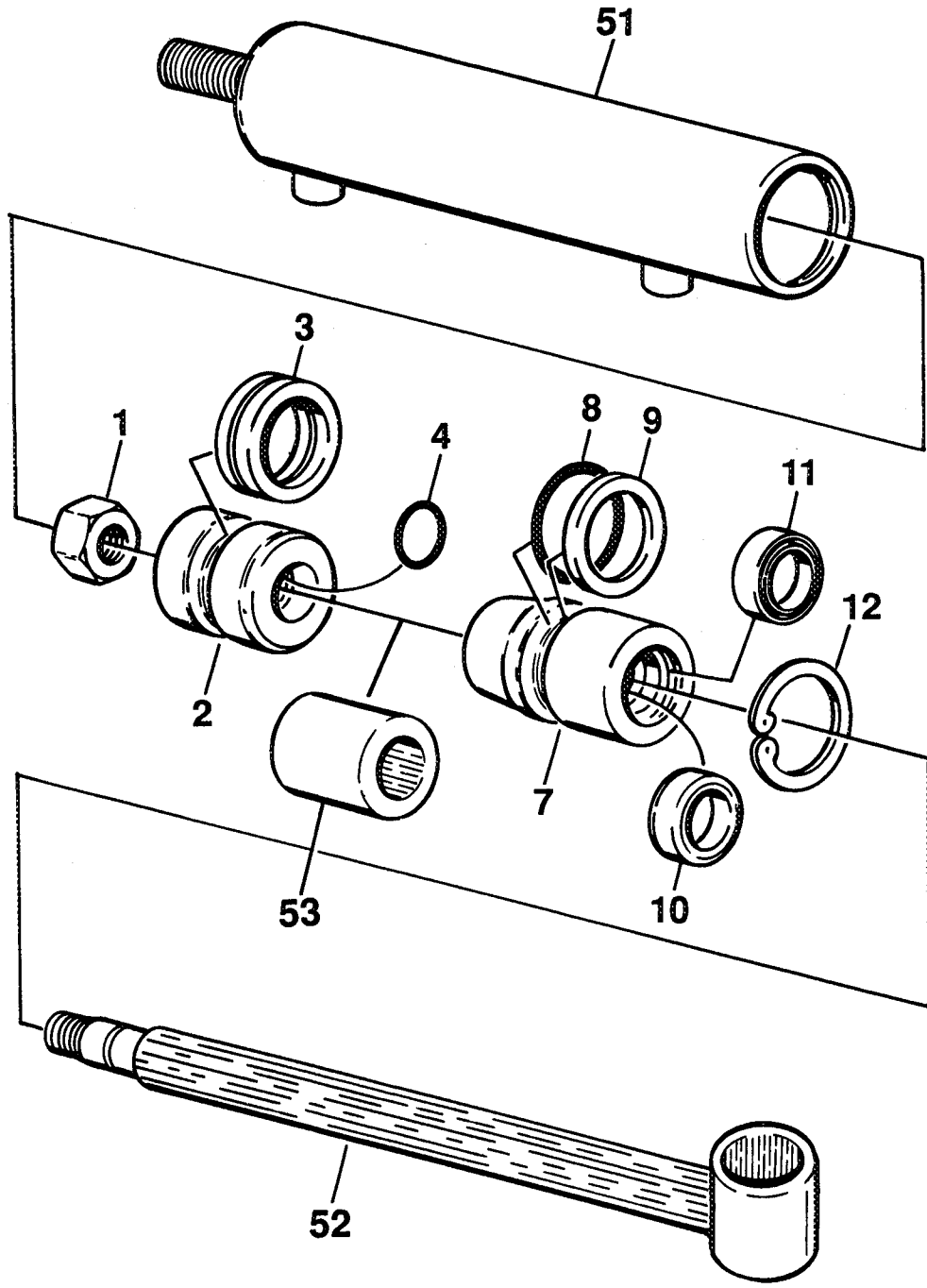

FIGURE 11-5-4. PLATFORM EXTENSION CYLINDER ASSEMBLY (HYDRAULICALLY EXTENDED DECK OPTION) (STANDARD PARTS).



SECTION 11-5 CYLINDERS

SECTION 11-5 CYLINDERS

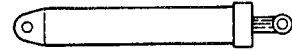

FIGURE & ITEM NO	PART NUMBER	DESCRIPTION	QTY.	REV.
11-5-4		PLATFORM EXTENSION CYLINDER ASSEMBLY (HYDRAULICALLY EXTENDED DECK OPTION) (STANDARD PARTS)	Ref.	
-1	7001084	Nut, Hex	1	
-2	7001610	Piston	1	
-3	Kit	Seal	1	
-4	Kit	O-Ring	1	
-5	Not Used			
-6	Not Used			
-7	7001613	Head	1	
-8	Kit	O-Ring	1	
-9	Kit	Ring, Back-up	1	
-10	Kit	Seal	1	
-11	Kit	Wiper	1	
-12	7001614	Ring, Retainer	1	
	7001608	Seal Kit - Cylinder (Includes Items 3,4, and 8-11)	1	
	1683204	PLATFORM EXTENSION CYLINDER ASSEMBLY - 4 FT. HYDRAULICALLY EXTENDED DECK (VARIABLE PARTS)	Ref.	—
-51	Consult Factory	Barrel Weldment	1	
-52	Consult Factory	Rod Weldment	1	
-53	Consult Factory	Spacer	1	
	1683199	PLATFORM EXTENSION CYLINDER ASSEMBLY - 6 FT. HYDRAULICALLY EXTENDED DECK (VARIABLE PARTS)	Ref.	—
-51	7001622	Barrel Weldment	1	
-52	7001624	Rod Weldment	1	
-153	7001623	Spacer	1	

SECTION 11-5 CYLINDERS

SECTION 11-5 CYLINDERS

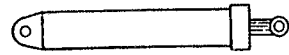
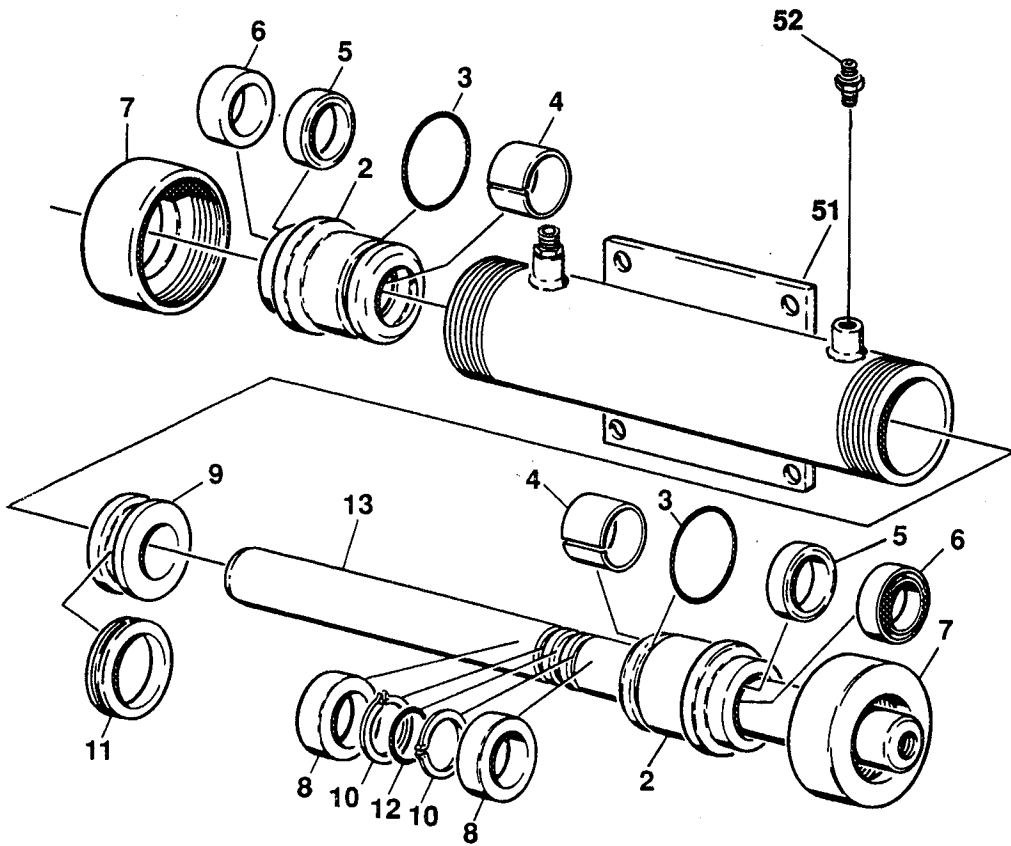
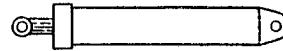

FIGURE 11-5-5. STEER CYLINDER ASSEMBLY.



SECTION 11-5 CYLINDERS

SECTION 11-5 CYLINDERS



SECTION 11-5 CYLINDERS

FIGURE & ITEM NO	PART NUMBER	DESCRIPTION	QTY.	REV.
11-5-5		STEER CYLINDER ASSEMBLY (STANDARD PARTS)	Ref.	
-1	Not Used			
-2	1682364	Head	2	
-3	Kit	O-Ring	2	
-4	Kit	Ring, Wear	2	
-5	Kit	Seal, Rod	2	
-6	Kit	Wiper	2	
-7	1120387	Retainer	2	
	0100035	Loctite	A/R	
-8	4564976	Spacer, Tube	2	
-9	3480153	Piston	1	
-10	3760141	Ring, Retaining	2	
-11	Kit	T-Seal	1	
-12	Kit	O-Ring	1	
-13	1682382	Rod	1	
	2901178	Seal Kit (Includes Items 3,4,5,6,11 and 12)	1	
	1682379	STEER CYLINDER ASSEMBLY - ALL MACHINES BUILT PRIOR TO JULY 1993 (VARIABLE PARTS)	Ref.	A
-51	1682380	Barrel	1	
-52	2220414	Fitting, Straight	2	
	1682996	STEER CYLINDER ASSEMBLY - CM2033 BUILT JULY 1993 TO SEPTEMBER 1995 (VARIABLE PARTS)	Ref.	A
-51	1682994	Barrel	1	
-52	2180803	Fitting	2	
	2180421	Orifice (.040) (July 1993 to June 1995)	2	
	2180804	Orifice (.040) (June 1995 to September 1995)	2	
	1682997	STEER CYLINDER ASSEMBLY - CM2046, CM2546 & CM2558 BUILT JULY 1993 TO SEPTEMBER 1995 (VARIABLE PARTS)	Ref.	C
-51	1682994	Barrel	1	
-52	2180803	Fitting	2	
	2180448	Orifice (.062) (July 1993 to June 1995)	2	
	2180805	Orifice (.062) (June 1995 to September 1995)	2	
	1683408	STEER CYLINDER ASSEMBLY - ALL MACHINES BUILT SEPTEMBER 1995 TO PRESENT (VARIABLE PARTS)	Ref.	—
-51	1682994	Barrel	1	
-52	2180803	Fitting	2	
	2180804	Orifice (.040) (CM2033)	2	
	2180805	Orifice (.062) (CM2046, CM2546 and CM2558)	2	
	0255702	OPTIONAL STEER REDUCTION INSTALLATION - CM2046, CM2246 AND CM2558 (NOT SHOWN)	Ref.	—
	2180804	Orifice (.040) (Replace existing orifice)	2	

SECTION 11-6

HYDRAULIC



TABLE OF CONTENTS

FIGURE NO.	TITLE	PAGE NO.
11-6-1	Hydraulic Diagram - Bang-Bang Drive	11-6-2
11-6-2	Hydraulic Diagram - Proportional Drive	11-6-6

Note: For Hydraulic Diagrams not shown, (listed below) request from the JLG Service Department.

- 1282298 Hydraulic Diagram - Hydraulically Extended Deck (Drawing Only)
- 2792155 CM2033/CM2046 (B/M Only)
- 2792156 CM2546/CM2558 (B/M Only)

SECTION 11-6 HYDRAULIC

SECTION 11-6 HYDRAULICS

FIGURE 11-6-1 HYDRAULIC DIAGRAM - BANG-BANG DRIVE.

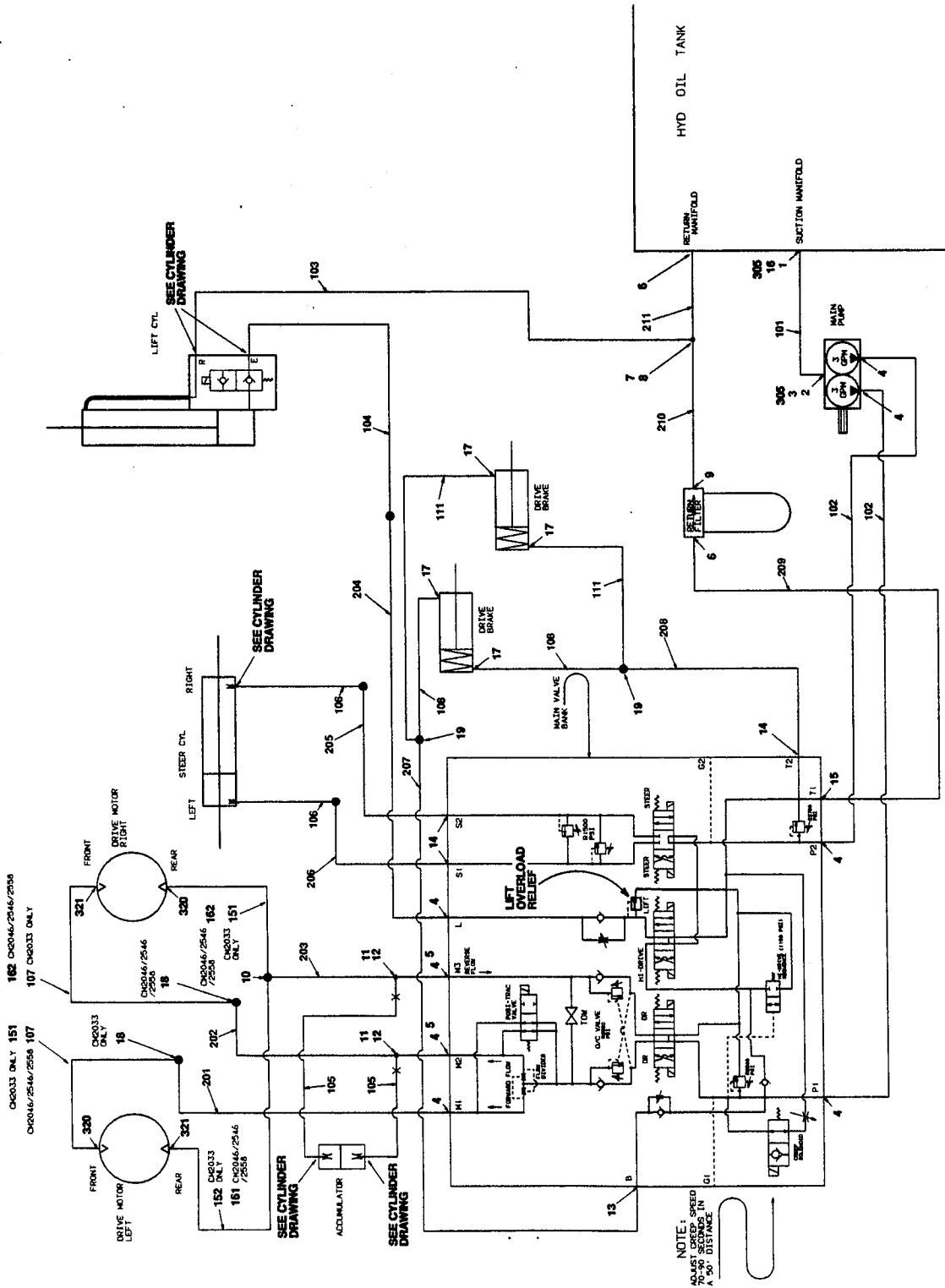

SECTION 11-6 HYDRAULICS

SECTION 11-6

HYDRAULICS



FIGURE & ITEM NO	PART NUMBER	DESCRIPTION	QTY.	REV.
11-6-1	1281465	HYDRAULIC DIAGRAM - BANG-BANG DRIVE	Ref.	J
	2901248	Fittings Kit	Ref.	—
—1	2220493	Fitting, 90°	1	
—2	2210008	Fitting, 90°	1	
—3	2220593	Fitting, Straight	1	
—4	2220600	Fitting, Straight	8	
—5	2220386	Fitting, 90°	2	
—6	2220847	Fitting, 90°	2	
—7	2220849	Fitting, Tee	1	
—8	2220620	Fitting, Reducer	1	
—9	2220848	Fitting, Straight	1	
—10	2220362	Fitting, Tee	1	
—11	2220385	Fitting, Tee	2	
—12	2220618	Fitting, Reducer	2	
—13	2220371	Fitting, Straight	1	
—14	2220603	Fitting, Straight	3	
—15	2220852	Fitting, Straight	1	
—16	2210023	Fitting, 90°	1	
—17	2220773	Fitting, 90°	4	
—18	2220512	Fitting	1	
—19	2220490	Fitting, Tee	2	
		HOSE KIT (STANDARD KIT)	Ref.	
—101	2720286	Hose, Suction	33 in./84cm	
—102	2750970	Hose	2	
—103	2752168	Hose	1	
—104	2751874	Hose	1	
—105	2750889	Hose	2	
—106	2751459	Hose	2	
—107	2751526	Hose	1	
—108	2750779	Hose	2	
—109	Not Used			
—110	Not Used			
—111	2751002	Hose	2	
	2901202	HOSE KIT - CM2033 (VARIABLE PARTS)	Ref.	B
—151	2751523	Hose	2	
—152	2751524	Hose	1	
	2901203	HOSE KIT - CM2046, CM2546 AND CM2558 (VARIABLE PARTS)	Ref.	B
—161	2751529	Hose	1	
—162	2751531	Hose	2	

SECTION 11-6 HYDRAULICS

SECTION 11-6 HYDRAULICS

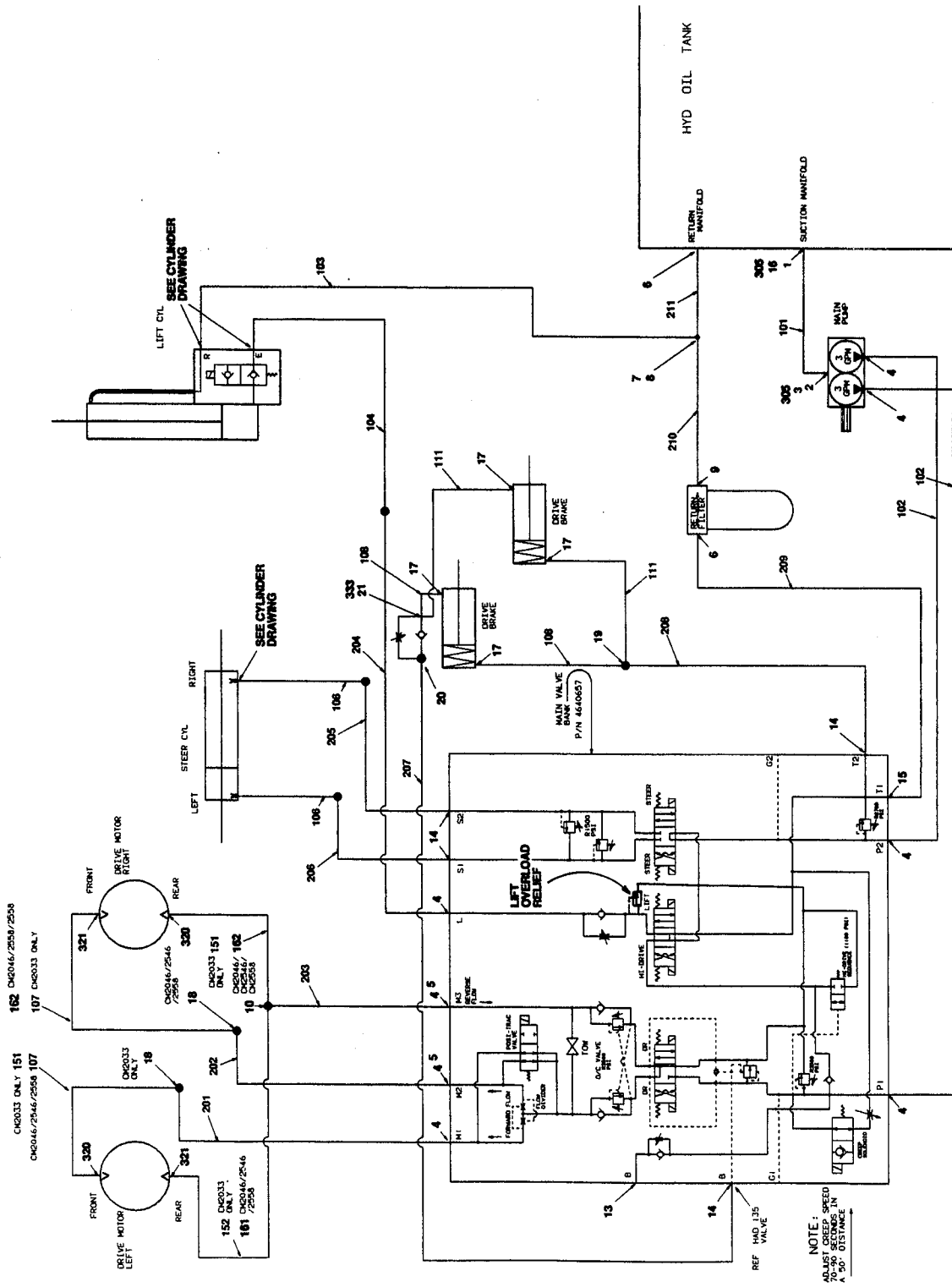

FIGURE & ITEM NO	PART NUMBER	DESCRIPTION	QTY.	REV.
11-6-1	1281465	HYDRAULIC DIAGRAM - BANG-BANG DRIVE (CONTINUED)	Ref.	J
	2901239	TUBE KIT	Ref.	—
—201	4564998	Tube	1	
—202	4564996	Tube	1	
—203	4564997	Tube	1	
—204	4564995	Tube	1	
—205	4564992	Tube	1	
—206	4564993	Tube	1	
—207	4564994	Tube	1	
—208	4564991	Tube	1	
—209	4564988	Tube	1	
—210	4564989	Tube	1	
—211	4564990	Tube	1	
	2791767	HYDRAULIC DIAGRAM - CM2033	Ref.	I
	2791768	HYDRAULIC DIAGRAM - CM2046, C,2546 AND CM2558	Ref.	J
—305	1320030	Clamp	4	
—320	2220850	Fitting, 90°	2	
	7012594	O-Ring Kit (1 per Fitting)	2	
—321	2220851	Fitting, 90°	2	
	7012594	O-Ring Kit (1 per Fitting)	2	
—347	0100011	Loctite #242 (Not Shown)	A/R	

SECTION 11 - 6 HYDRAULICS

SECTION 11-6 HYDRAULICS

FIGURE 11-6-2. HYDRAULIC DIAGRAM - PROPORTIONAL DRIVE.



SECTION 11-6 HYDRAULICS

SECTION 11-6

HYDRAULICS



SECTION 11-6 HYDRAULICS

FIGURE & ITEM NO	PART NUMBER	DESCRIPTION	QTY.	REV.
11-6-2	1281760	HYDRAULIC DIAGRAM - PROPORTIONAL DRIVE	Ref.	D
	2901254	FITTINGS KIT	Ref.	—
—1	2220493	Fitting, 90°	1	
—2	2210008	Fitting, 90°	1	
—3	2220593	Fitting, Straight	1	
—4	2220600	Fitting, Straight	8	
—5	2220386	Fitting, 90°	2	
—6	2220847	Fitting, 90°	2	
—7	2220849	Fitting, Tee	1	
—8	2220620	Fitting, Reducer	1	
—9	2220848	Fitting, Straight	1	
—10	2220362	Fitting, Tee	1	
—11	2220385	Fitting, Tee	2	
—12	2220618	Fitting, Reducer	2	
—13	2220237	Fitting	1	
—14	2220603	Fitting, Straight	4	
—15	2220852	Fitting, Straight	1	
—16	2210023	Fitting, 90°	1	
—17	2220773	Fitting, 90°	4	
—18	2220512	Fitting	1	
—19	2220490	Fitting, Tee	1	
—20	2220399	Fitting, Straight	1	
—21	2220740	Fitting, Tee	1	
	1281760	HOSE KIT (STANDRD PARTS)	Ref.	D
—101	2720286	Hose, Suction	1	
—102	2750970	Hose	2	
—103	2752168	Hose	1	
—104	2251874	Hose	1	
—105	Not Used			
—106	2751459	Hose	2	
—107	2751526	Hose	1	
—108	2750779	Hose	2	
—109	Not Used			
—110	Not Used			
—111	2751002	Hose	2	
	2901245	HOSE KIT - CM2033 (VARIABLE PARTS)	Ref.	—
—151	2751523	Hose	2	
—152	2751524	Hose	1	
	2901246	HOSE KIT - CM2046, CM2546 AND CM2558 (VARIABLE PARTS)	Ref.	—
—161	2751529	Hose	1	
—162	2751531	Hose	2	

SECTION 11-6

HYDRAULICS



FIGURE & ITEM NO	PART NUMBER	DESCRIPTION	QTY.	REV.
11-6-2	1281760	HYDRAULIC DIAGRAM - PROPORTIONAL DRIVE (CONTINUED)	Ref.	D
	2901247	TUBE KIT (STANDARD PARTS)	Ref.	—
—201	4564998	Tube	1	
—202	4566036	Tube	1	
—203	4566037	Tube	1	
—204	4564995	Tube	1	
—205	4564992	Tube	1	
—206	4564993	Tube	1	
—207	4566038	Tube	1	
—208	4564991	Tube	1	
—209	4564988	Tube	1	
—210	4564989	Tube	1	
—211	4564990	Tube	1	
	2791912	HYDRAULIC DIAGRAM - CM2033	Ref.	B
	2791913	HYDRAULIC DIAGRAM - CM2046, CM2546 AND CM2558	Ref.	B
—305	1320030	Clamp	4	
—320	2220850	Fitting, Swivel	2	
	7012594	O-Ring Kit (1 per Fitting)	2	
—321	2220851	Fitting, Swivel	2	
	7012594	O-Ring Kit (1 per Fitting)	2	
—333	4640128	Valve	1	
—347	0100011	Loctite #242	A/R	

SECTION 11 - 6 HYDRAULICS

SECTION 11-7

ELECTRICAL

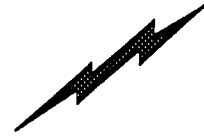

TABLE OF CONTENTS

FIGURE NO.	TITLE	PAGE NO.
11-7-1	Electrical Diagrams and Components Chart.	11-7-2
11-7-2	Electrical Diagram - Toggle Switch Drive	11-7-10
11-7-3	Electrical Diagram - PQ Controller Bang-Bang Drive	11-7-11
11-7-4	Electrical Diagram - PQ Controller Proportional Drive	11-7-12
11-7-5	Electrical Diagram - Circuit Cards.	11-7-13
11-7-6	Main Electrical Connector and Tools.	11-7-14

**S
E
C
T
I
O
N

1
1
-
7

E
L
E
C
T
R
I
C
A
L**

SECTION 11-7 ELECTRICAL

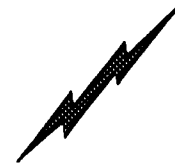

SECTION 11-7 ELECTRICAL

FIGURE & ITEM NO	PART NUMBER	DESCRIPTION	QTY.	REV.
11-7-1		ELECTRICAL DIAGRAMS AND COMPONENTS CHART	Ref.	
		(Note: *Indicates Diagrams shown in the following pages. Diagrams not shown are available from JLG Service Department upon request.)		
	1281570	ALARMS ELECTRICAL DIAGRAM STANDARD (DWG. ONLY)	Ref.	E
	0251762	ALARM ELECTRICAL DIAGRAM - DESCENT (B/M ONLY)	Ref.	B
	0251761	ALARM ELECTRICAL DIAGRAM - MOTION (TOGGLE SWITCH DRIVE) (B/M ONLY)	Ref.	B
	0254268	ALARM ELECTRICAL DIAGRAM - MOTION (PQ BANG-BANG DRIVE) (B/M ONLY)	Ref.	—
	0251760	ALARM ELECTRICAL DIAGRAM - TRAVEL (TOGGLE SWITCH DRIVE) (B/M ONLY)	Ref.	B
	0254267	ALARM ELECTRICAL DIAGRAM - TRAVEL PQ BANG-BANG DRIVE) (B/M ONLY)	Ref.	—
	0140033	Alarm, Motion	1	
	3990010	Diode - 6 Amp	A/R	
	1281570	ALARMS ELECTRICAL DIAGRAM - UL LISTED (DWG. ONLY)	Ref.	E
	0254287	ALARM ELECTRICAL DIAGRAM - DESCENT (B/M ONLY)	Ref.	A
	0254285	ALARM ELECTRICAL DIAGRAM - MOTION (TOGGLE SWITCH DRIVE) (B/M ONLY)	Ref.	B
	0254288	ALARM ELECTRICAL DIAGRAM - MOTION (PQ BANG-BANG DRIVE) (B/M ONLY)	Ref.	—
	0254286	ALARM ELECTRICAL DIAGRAM - TRAVEL (TOGGLE SWITCH DRIVE) (B/M ONLY)	Ref.	A
	0254289	ALARM ELECTRICAL DIAGRAM - TRAVEL (PQ BANG-BANG DRIVE) (B/M ONLY)		
	0140033	Alarm, Motion	1	
	3990010	Diode - 6 Amp	A/R	
	0251758	BATTERY/HOUR GAUGE ELECTRICAL DIAGRAM (STEEL CONSOLE BOX)	Ref.	B
	0253499	BATTERY/HOUR GAUGE ELECTRICAL DIAGRAM (MOLDED CONSOLE BOX)	Ref.	A
	2420106	Gauge, Battery/Hour	1	
	0252274	BEACON LIGHT ELECTRICAL DIAGRAM (FRAME MOUNTED)	Ref.	A
	2920087	Light Beacon	1	
	1060341	Cable, Electrical - 16/2	6 ft./1.8m	
	0251870	BEACON LIGHT ELECTRICAL DIAGRAM (PLATFORM MOUNTED LIGHT/STEEL CONSOLE BOX)	Ref.	B
	2920092	Light Beacon	1	
	1060341	Cable, Electrical	16 ft./5m	
	4460049	Connector, Strain Relief (Located at Console Box)	1	
	3300047	Locknut, Conduit (Located at Console Box)	1	
	0960239	Bushing (Located at Console Box)	1	

SECTION 11-7 ELECTRICAL

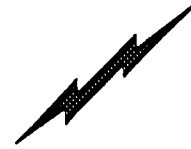

FIGURE & ITEM NO	PART NUMBER	DESCRIPTION	QTY.	REV.
11-7-1		ELECTRICAL DIAGRAMS AND COMPONENTS CHART (CONTINUED)	Ref.	
	1281952	BEACON LIGHT ELECTRICAL DIAGRAM (PLATFORM MOUNTED LIGHT/MOLDED CONSOLE BOX) (DWG ONLY)	Ref.	A
	0253476	BEACON LIGHT ELECTRICAL DIAGRAM - STANDARD CM2033 AND CM2046 (B/M ONLY)	Ref.	—
	0253477	BEACON LIGHT ELECTRICAL DIAGRAM - U/L APPROVED CM2033 AND CM2046 (B/M ONLY)	Ref.	—
	0253478	BEACON LIGHT ELECTRICAL DIAGRAM - STANDARD CM2546 AND CM2558 (B/M ONLY)	Ref.	—
	0253479	BEACON LIGHT ELECTRICAL DIAGRAM - U/L APPROVED CM2546 AND CM2558 (B/M ONLY)	Ref.	—
	2920087	Light, Beacon - Standard	1	
	2920092	Light, Beacon - U/L Approved	1	
	1060341	Cable, Electrical - 16/2 CM2033 and CM2046 CM2546 and CM2558	A/R 54 ft./16.5m 62 ft./19m	
	0253814	BEACON LIGHT ELECTRICAL DIAGRAM (UNDER PLATFORM MOUNTED)	Ref.	B
		CIRCUIT CARD ELECTRICAL DIAGRAM (ENABLE)	Ref.	
	0610101	Prior to January 1995	Ref.	
	0610113*	January 1995 to Present	Ref.	—
	0610105*	CIRCUIT CARD ELECTRICAL DIAGRAM (RELAY)	Ref.	
	1281645	DRIVE CUTOUT ELECTRICAL DIAGRAM (STEEL CONSOLE BOX) (DWG ONLY)	Ref.	E
	0252097	DRIVE CUTOUT ELECTRICAL DIAGRAM (STEEL CONSOLE BOX) (B/M ONLY)	Ref.	—
	1281950	DRIVE CUTOUT ELECTRICAL DIAGRAM (MOLDED CONSOLE BOX) (DWG ONLY)	Ref.	A
	0253491	DRIVE CUTOUT ELECTRICAL DIAGRAM (MOLDED CONSOLE BOX) (B/M ONLY)	Ref.	A
	4360300	Switch, Limit	1	
	1060341	Cable, Control - 16/2	15 ft./4.6m	
	0254029	HEADLIGHT ELECTRICAL DIAGRAM (SEE SECTION 11-9 FOR SERVICE PARTS)	Ref.	—
	0255703	HIGH SPEED DISCONNECT ELECTRICAL DIAGRAM	Ref.	—
	0251788	HORN ELECTRICAL DIAGRAM (STEEL CONSOLE BOX)	Ref.	B
	0253465	HORN ELECTRICAL DIAGRAM (MOLDED CONSOLE BOX)	Ref.	A
	0140022	Horn	1	
	4360274	Switch, Push Button	1	
	1060341	Cable, Electrical - 16/2	8 ft./2.4m	
	1282224	HOURMETER AT GROUND CONTROL ELECTRICAL DIAGRAM	Ref.	—

SECTION 11-7 ELECTRICAL

SECTION 11-7 ELECTRICAL

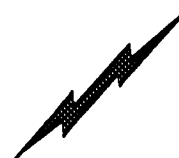

FIGURE & ITEM NO	PART NUMBER	DESCRIPTION	QTY.	REV.
11-7-1		ELECTRICAL DIAGRAMS AND COMPONENTS CHART (CONTINUED)	Ref.	
	1282310	PLATFORM DECK ELECTRICAL DIAGRAM (HYDRAULICALLY EXTENDED DECK) (DWG. ONLY)	Ref.	A
	4932718	CM2033 (B/M Only)	Ref.	—
	4932719	CM2546 (B/M Only)	Ref.	D
	3990010	Diode - 6 Amp	1	
	1060331	Cable, Electrical - 16/4 CM2033/2046	A/R 44 ft.	
		CM2546/2558	50 ft.	
	4921558	Cable Assembly (CM2033/2046)	1	
	4921556	Cable Assembly (CM2546/2558)	1	
	4921709	Harness	1	
	0239707/9983590	PLATFORM WORKLIGHTS ELECTRICAL DIAGRAM (STANDARD MACHINES WITH STEEL CONSOLE BOX)	Ref.	—/—
	0250305	PLATFORM WORKLIGHTS ELECTRICAL DIAGRAM (U/L APPROVED MACHINES WITH MOLDED CONSOLE BOX)	Ref.	—
	1281951	PLATFORM WORKLIGHTS ELECTRICAL DIAGRAM (MOLDED CONSOLE BOX) (DWG ONLY)	Ref.	A
	0253504	PLATFORM WORKLIGHTS ELECTRICAL DIAGRAM (STANDARD CM2033 AND CM2046 WITH MOLDED CONSOLE BOX) (B/M ONLY)	Ref.	—
	0253505	PLATFORM WORKLIGHTS ELECTRICAL DIAGRAM (U/L APPROVED CM2033 AND CM2046 WITH MOLDED CONSOLE BOX) (B/M ONLY)	Ref.	—
	0253506	PLATFORM WORKLIGHTS ELECTRICAL DIAGRAM (STANDARD CM2546 AND CM2558 WITH MOLDED CONSOLE BOX) (B/M ONLY)	Ref.	—
	0253507	PLATFORM WORKLIGHTS ELECTRICAL DIAGRAM (U/L APPROVED CM2546 AND CM2558 WITH MOLDED CONSOLE BOX) (B/M ONLY)	Ref.	—
	2920088	Worklight (Standard Machines with Steel Console Box)	2	
	2920093	Worklight (All U/L Approved Machines/Standard Machines with Molded Console Boxes)	2	
	1060341	Cable, Electrical - 16/2 (Molded Console Box Only) CM2033/CM2046	A/R 54 ft./16.5m	
		CM2546/CM2558	62 ft./19m	
		STANDARD "GROUND TO PLATFORM" CABLE/HARNESS WITH STEEL CONSOLE BOX:	Ref.	
	1060306	CM2033 and CM2046 Standard Machines	Ref. 48 ft./15.2m	
	1060325	CM2033 and CM2046 U/L Approved Machines	48 ft./15.2m	
	1060306	CM2546 and CM2558 Standard Machines	54 ft./16.5m	
	1060325	CM2546 and CM2558 U/L Approved Machines	54 ft./16.5m	
		WITH MOLDED CONSOLE BOX:	Ref.	
	4921516	CM2033 and CM2046 Standard Machines	1	
	1060325	CM2033 and CM2046 U/L Approved Machines	48 ft./15.2m	
	4921519	CM2546 and CM2558 Standard Machines	1	
	1060325	CM2546 and CM2558 U/L Approved Machines	84 ft./19.5m	

SECTION 11-7 ELECTRICAL

SECTION 11-7 ELECTRICAL

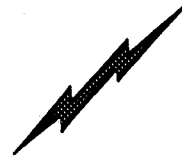

FIGURE & ITEM NO	PART NUMBER	DESCRIPTION	QTY.	REV.
11-7-1		ELECTRICAL DIAGRAMS AND COMPONENTS CHART (CONTINUED)	Ref.	
	1281557	STANDARD ELECTRICAL DIAGRAM - TOGGLE SWITCH DRIVE/STEEL CONSOLE BOX/STANDARD MACHINE (DWG ONLY)	Ref.	D
	4932322	Ground Components (B/M Only)	Ref.	E
	4932369	Platform Components (B/M Only)	Ref.	B
	4921306	Valve and Ground Control Harness	1	D
	4460277	Strip, Terminal - 14 Position	1	
	3990010	Diode - 6 Amp	7	
	1060341	Cable, Electrical - 16/2 (To Cutout Switch/To Lift Down Solenoid)	30 ft./9m	
	1281879*	STANDARD ELECTRICAL DIAGRAM - TOGGLE SWITCH DRIVE /MOLDED CONSOLE BOX/STANDARD MACHINE (DWG ONLY)	Ref.	B
	4932517	Ground Components (B/M Only)	Ref.	A
	4932518	Platform Components (B/M Only)	Ref.	A
	4921454	Valve and Ground Control Harness	1	
	4460277	Strip, Terminal - 14 Position	1	
	3990010	Diode - 6 Amp	7	
	1060341	Cable, Electrical - 16/2 (To Cutout Switch/To Lift Down Solenoid)	30 ft./9m	
	1281668	STANDARD ELECTRICAL DIAGRAM - TOGGLE SWITCH DRIVE/STEEL CONSOLE BOX/UL APPROVED MACHINE (DWG ONLY)	Ref.	—
	4932426	Ground Components (B/M Only)	Ref.	—
	4932427	Platform Components (B/M Only)	Ref.	A
	4921386	Valve and Ground Control Harness	1	
	4460277	Strip, Terminal - 14 Position	1	
	3990010	Diode - 6 Amp	7	
	1060341	Cable, Electrical - 16/2 (To Cutout Switch/To Lift Down Solenoid)	30 ft./9m	
	1281891	STANDARD ELECTRICAL DIAGRAM - TOGGLE SWITCH DRIVE/MOLDED CONSOLE BOX/UL APPROVED MACHINE (DWG ONLY)	Ref.	C
	4932553	Ground Components (B/M Only)	Ref.	A
	4932554	Platform Components (B/M Only)	Ref.	A
	4921478	Valve and Ground Control Harness	1	
	4460277	Strip, Terminal - 14 Position	1	
	3990010	Diode - 6 Amp	7	
	1060341	Cable, Electrical - 16/2 (To Cutout Switch/To Lift Down Solenoid)	30 ft./9m	
	4932731	Wiring Diagram Retrofit - UL "EE"	Ref.	—

SECTION 11-7 ELECTRICAL

SECTION 11-7 ELECTRICAL



SECTION 11-7 ELECTRICAL

FIGURE & ITEM NO	PART NUMBER	DESCRIPTION	QTY.	REV.
11-7-1		ELECTRICAL DIAGRAMS AND COMPONENTS CHART (CONTINUED)	Ref.	
	1281558	STANDARD ELECTRICAL DIAGRAM - PQ BANG-BANG DRIVE/STEEL CONSOLE BOX/STANDARD MACHINE (DWG ONLY)	Ref.	C
	4932331	Ground Components (B/M Only)	Ref.	D
	4932371	Platform Components (B/M Only)	Ref.	A
	4921306	Valve and Ground Control Harness	1	D
	4460277	Strip, Terminal - 14 Position	1	
	3990010	Diode - 6 Amp	7	
	1060341	Cable, Electrical - 16/2 (To Cutout Switch/To Lift Down Solenoid)	30 ft./9m	
	4921308	PQ Controller Harness	1	
	1281880*	STANDARD ELECTRICAL DIAGRAM PQ BANG-BANG DRIVE/MOLDED CONSOLE BOX/STANDARD MACHINE (DWG ONLY)	Ref.	B
	4932520	Ground Components (B/M Only)	Ref.	B
	4932521	Platform Components (B/M Only)	Ref.	—
	4921454	Valve and Ground Control Harness	1	—
	4460277	Strip, Terminal - 14 Position	1	
	3990010	Diode - 6 Amp	7	
	1060341	Cable, Electrical - 16/2 (To Cutout Switch/To Lift Down Solenoid)	30 ft./9m	
	1281669	STANDARD ELECTRICAL DIAGRAM - PQ BANG-BANG DRIVE/STEEL CONSOLE BOX/UL APPROVED MACHINE (DWG ONLY)	Ref.	—
	4932428	Ground Components (B/M Only)	Ref.	—
	4932429	Platform Components (B/M Only)	Ref.	—
	4921386	Valve and Ground Control Harness	1	—
	4460277	Strip, Terminal - 14 Position	1	
	3990010	Diode - 6 Amp	7	
	1060341	Cable, Electrical - 16/2 (To Cutout Switch/To Lift Down Solenoid)	30 ft./9m	
	4921308	PQ Controller Harness	1	
	1281892	STANDARD ELECTRICAL DIAGRAM - PQ BANG-BANG DRIVE/MOLDED CONSOLE BOX/UL APPROVED MACHINE (DWG ONLY)	Ref.	B
	4932556	Ground Components (B/M Only)	Ref.	A
	4932557	Platform Components (B/M Only)	Ref.	—
	4921480	Valve and Ground Control Harness	1	—

SECTION 11-7 ELECTRICAL



SECTION 11-7 ELECTRICAL

FIGURE & ITEM NO	PART NUMBER	DESCRIPTION	QTY.	REV.
11-7-1		ELECTRICAL DIAGRAMS AND COMPONENTS CHART (CONTINUED)	Ref.	
	4460277	Strip, Terminal - 14 Position	1	
	3990010	Diode - 6 Amp	7	
	1060341	Cable, Electrical - 16/2 (To Cutout Switch/To Lift Down Solenoid)	30 ft./9m	
	4932732	Wiring Diagram Retrofit - UL "EE"	Ref.	—
	1281780	STANDARD ELECTRICAL DIAGRAM - PQ PROPORTIONAL DRIVE/STEEL CONSOLE BOX/STANDARD MACHINE (DWG ONLY)	Ref.	B
	4932477	Ground Components (B/M Only)	Ref.	—
	4932475	Platform Components (B/M Only)	Ref.	A
	4921408	Valve and Ground Control Harness	1	A
	4460277	Strip, Terminal - 14 Position	1	
	3990010	Diode - 6 Amp	5	
	1060341	Cable, Electrical - 16/2 (To Cutout Switch/To Lift Down Solenoid)	30 ft./9m	
	4921412	PQ Controller Harness	1	
	3990010	Diode - 6 Amp	1	
	1281881*	STANDARD ELECTRICAL DIAGRAM - PQ PROPORTIONAL DRIVE/MOLDED CONSOLE BOX/STANDARD MACHINE (DWG ONLY)	Ref.	D
	4932523	Ground Components (B/M Only)	Ref.	B
	4932524	Platform Components (B/M Only)	Ref.	—
	4921458	Valve and Ground Control Harness	1	A
	4460277	Strip, Terminal - 14 Position	1	
	3990010	Diode - 6 Amp	5	
	1060341	Cable, Electrical - 16/2 (To Cutout Switch/To Lift Down Solenoid)	30 ft./9m	
	3990010	Diode - 6 Amp	1	
	1281765	STANDARD ELECTRICAL DIAGRAM - PQ PROPORTIONAL DRIVE/STEEL CONSOLE BOX/UL APPROVED MACHINE (DWG ONLY)	Ref.	A
	4932464	Ground Components (B/M Only)	Ref.	A
	4932465	Platform Components (B/M Only)	Ref.	—
	4921405	Valve and Ground Control Harness	1	—
	4460277	Strip, Terminal - 14 Position	1	
	3990010	Diode - 6 Amp	5	
	1060341	Cable, Electrical - 16/2 (To Cutout Switch/To Lift Down Solenoid)	30 ft./9m	
	4921308	PQ Controller Harness	1	
	1281893	STANDARD ELECTRICAL DIAGRAM - PQ PROPORTIONAL DRIVE/MOLDED CONSOLE BOX/UL APPROVED MACHINE (DWG ONLY)	Ref.	D
	4932559	Ground Components (B/M Only)	Ref.	B
	4932560	Platform Components (B/M Only)	Ref.	—

SECTION 11-7 ELECTRICAL

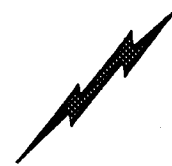
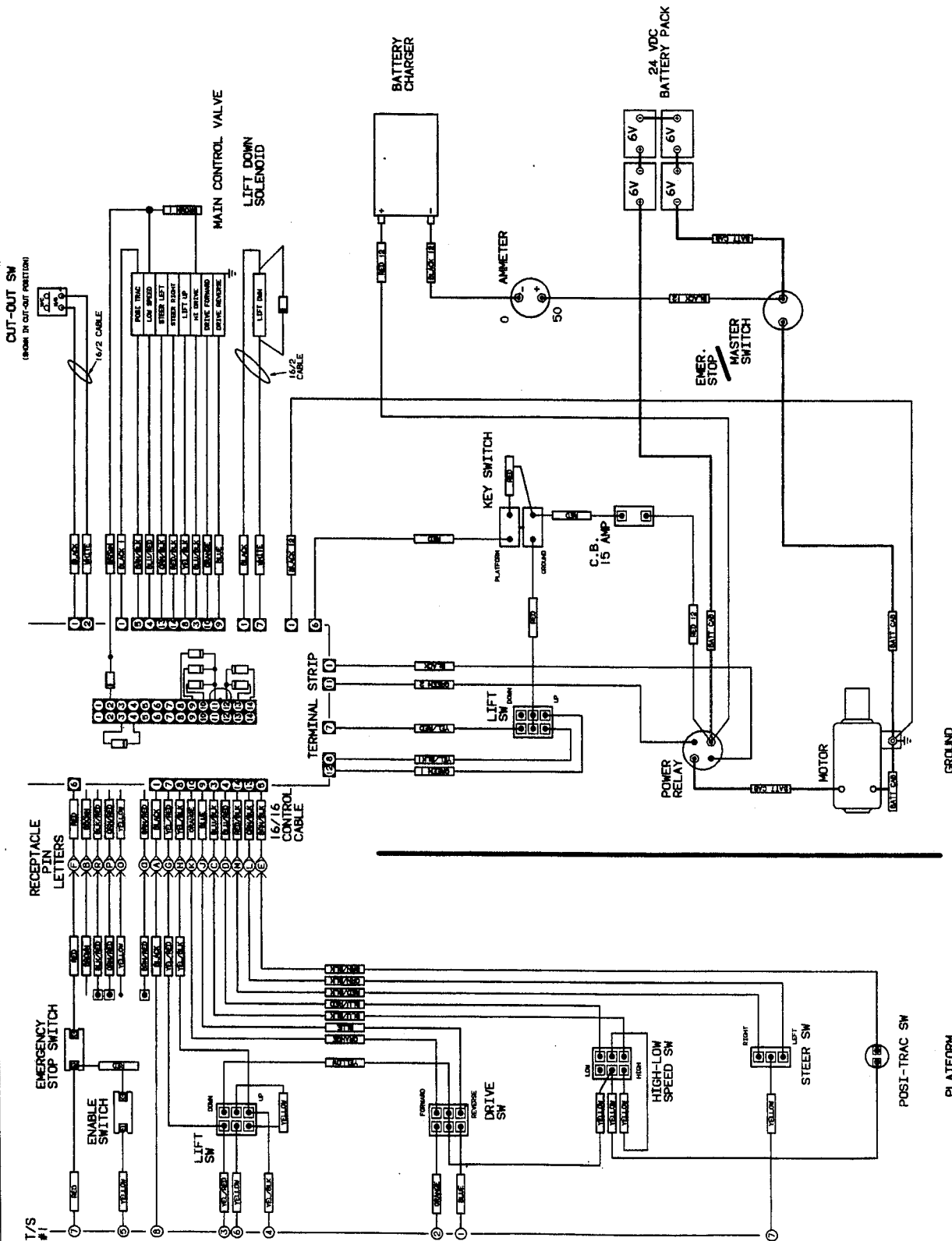
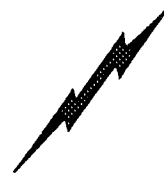

FIGURE & ITEM NO	PART NUMBER	DESCRIPTION	QTY.	REV.
11-7-1		<p>ELECTRICAL DIAGRAMS AND COMPONENTS CHART (CONTINUED)</p> <p>4921482 Valve and Ground Control Harness 1 A</p> <p>4460277 Strip, Terminal - 14 Position 1</p> <p>3990010 Diode - 6 Amp 5</p> <p>1060341 Cable, Electrical - 16/2 (To Cutout Switch/To Lift Down Solenoid) 30 ft./9m</p> <p>3990010 Diode - 6 Amp 1</p> <p>4932733 Wiring Diagram Retrofit - UL "EE" Ref. —</p> <p>1281874 TILT INDICATOR ELECTRICAL DIAGRAM (STEEL CONSOLE BOX/STANDARD MACHINES) (DWG ONLY) Ref. C</p> <p>0251724 TILT INDICATOR ELECTRICAL DIAGRAM (B/M ONLY) Ref. C</p> <p>1281949 TILT INDICATOR ELECTRICAL DIAGRAM (MOLDED CONSOLE BOX) (DWG ONLY) Ref. F</p> <p>0253485 TILT INDICATOR ELECTRICAL DIAGRAM (B/M ONLY) Ref. —</p> <p>0252311 TILT INDICATOR ELECTRICAL DIAGRAM (STEEL CONSOLE BOX/UL APPROVED MACHINES) Ref. A</p> <p>4360303 Tilt Switch/Harness Assembly 1</p> <p>4360171 Switch, Tilt 1</p> <p>1060171 Cable, Electrical - 16/3 9 ft./2.7m</p> <p>3740069 Relay, Power (Steel Console Box Only) 1</p> <p>2920026 Light, Indicator - Red (Located on Console Box) 1</p> <p>2920094 Bulb, Lamp (Located on Console Box) 1</p> <p>4460007 Strip, Terminal - 6 Position 1</p> <p>1060330 Cable, Electrical - 16/3 (To Cutout Switch) (Standard Machines) 10 ft./3m</p> <p>1060300 Cable, Electrical - 16/3 (To Cutout Switch) (UL Approved Machines) 10 ft./3m</p> <p>0140011 Alarm, Sonalert 1</p> <p>1670547 Cover, Tilt Switch (UL Approved Machines Only) 1</p>		

SECTION 11-7 ELECTRICAL

SECTION 11-7 ELECTRICAL

FIGURE 11-7-2. ELECTRICAL DIAGRAM -TOGGLE SWITCH DRIVE.



1281879 B

SECTION 11-7 ELECTRICAL

SECTION 11-7 ELECTRICAL

FIGURE 11-7-3. ELECTRICAL DIAGRAM -PQ CONTROLLER BANG-BANG DRIVE.

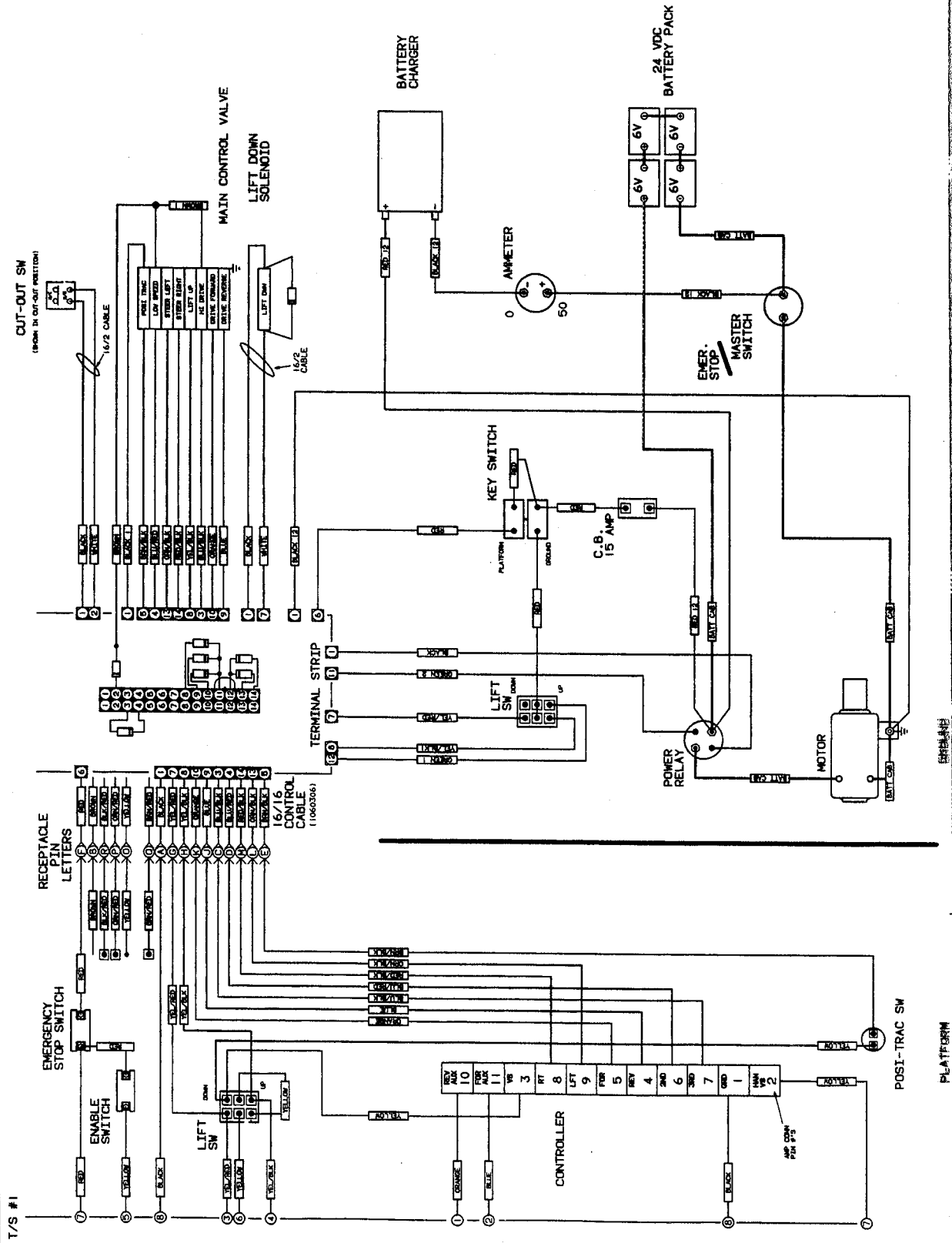

1281880 B

ELECTRICAL SECTION 11-7

SECTION 11-7 ELECTRICAL

FIGURE 11-7-4. ELECTRICAL DIAGRAM -PQ CONTROLLER PROPORTIONAL DRIVE.

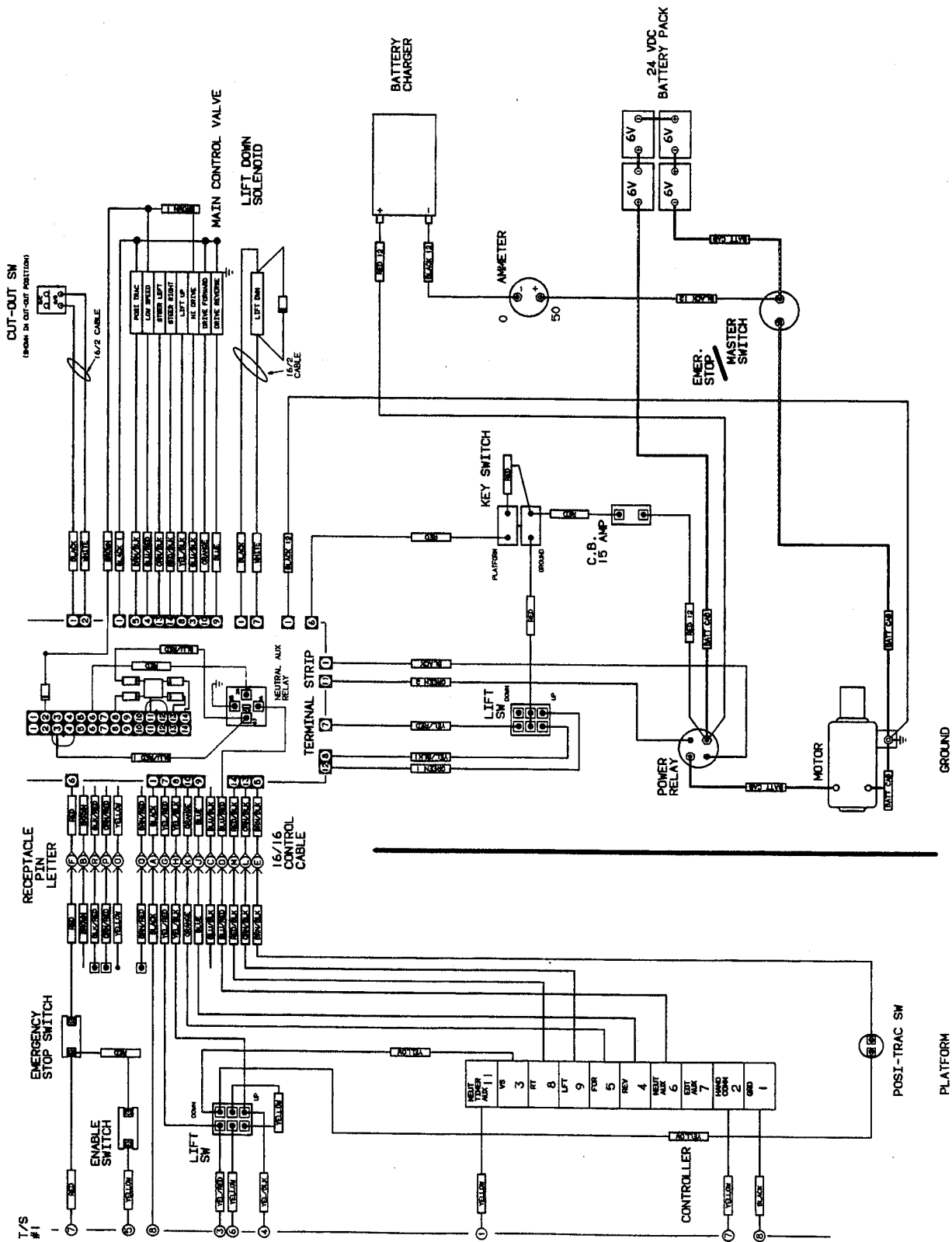

1281881 D

CAL-TRAC M-11 ZONE-HOMS

SECTION 11-7 ELECTRICAL

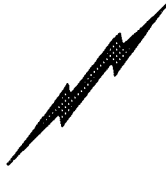
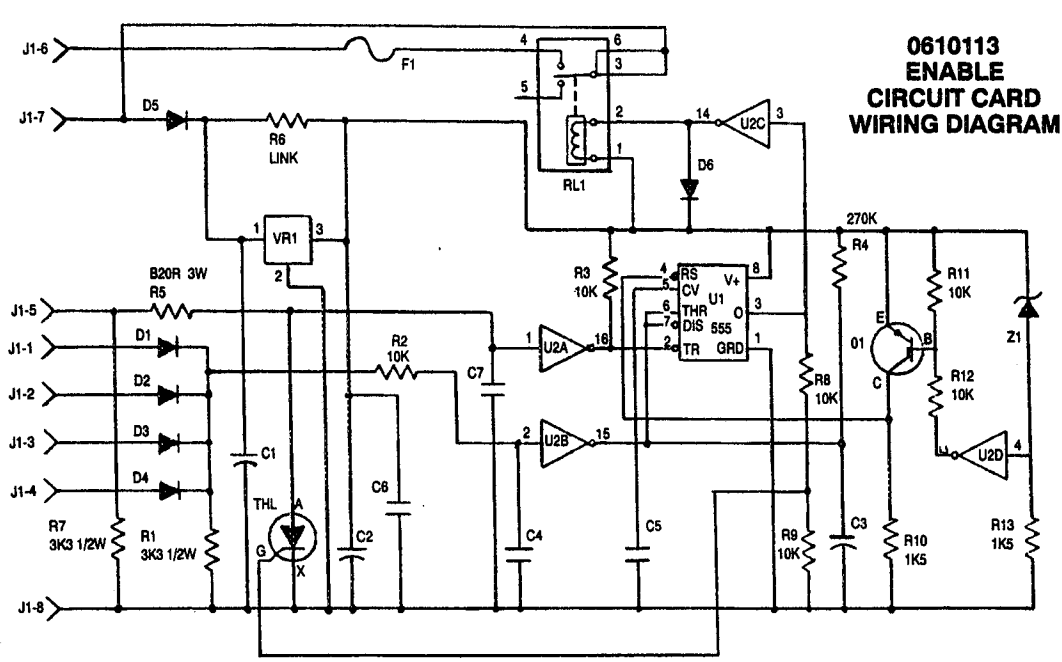
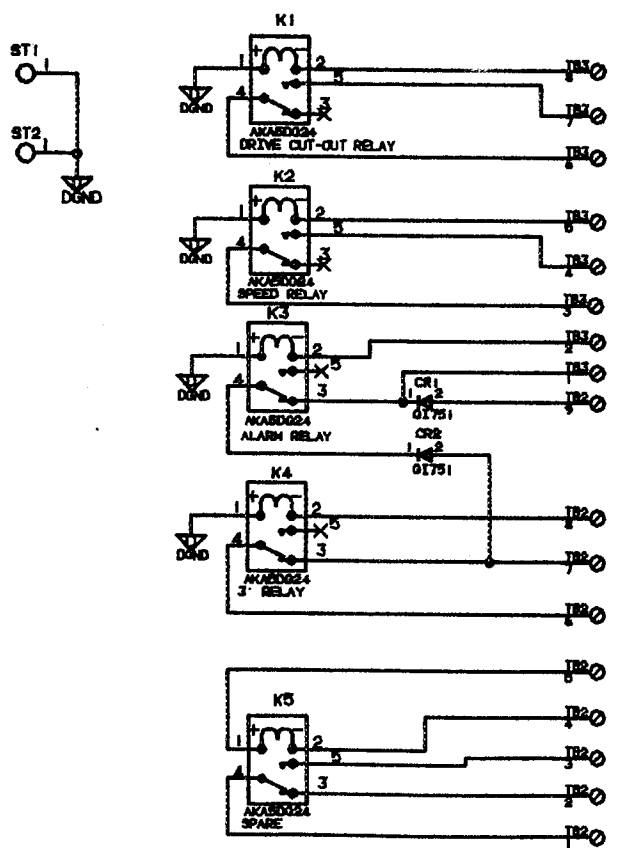

FIGURE 11-7-5. ELECTRICAL DIAGRAM - CIRCUIT CARDS.



**0610113
ENABLE
CIRCUIT CARD
WIRING DIAGRAM**



**0610105
RELAY
CIRCUIT CARD
WIRING DIAGRAM**

SECTION 11-7 ELECTRICAL

SECTION 11-7 ELECTRICAL

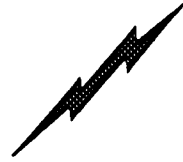
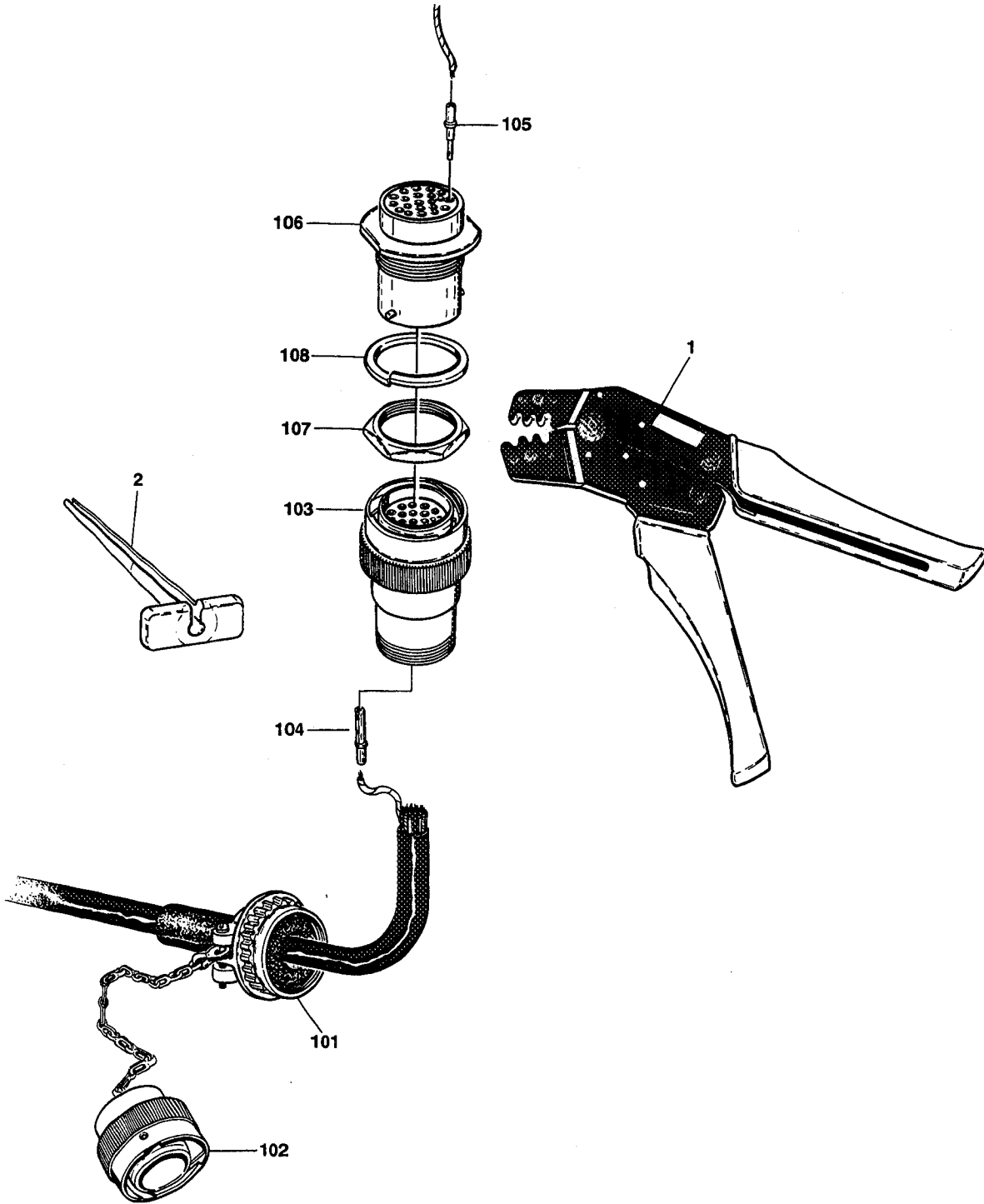

FIGURE 11-7-6. MAIN ELECTRICAL CONNECTOR AND TOOLS.



SECTION 11-7 ELECTRICAL

SECTION 11-7 ELECTRICAL

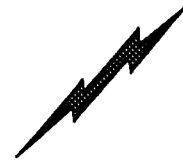

FIGURE & ITEM NO	PART NUMBER	DESCRIPTION	QTY.	REV.
11-7-6		MAIN ELECTRICAL CONNECTOR AND TOOLS	Ref.	
		Tools:	Ref.	
-1	7002818	Crimper (For Wire to Pin/Socket Connections)	1	
-2	4460467	Extractor (For Removal of Pins/Sockets from Connectors)	1	
		Connector Components:	Ref.	
-101	4460473	Clamp, Cable	1	
-102	4460468	Cap, Dust	1	
-103	4460462	Plug, Connector - 23 Pin (Female)	1	
-104	4460465	Socket, Female	A/R	
-105	4460464	Pin, Male	A/R	
-106	4460463	Receptacle, Connector - 23 Pin (Male)	1	
-107	4460470	Nut, Receptacle	1	
-108	4460471	Lockwasher, Receptacle	1	

SECTION 11-7 ELECTRICAL

SECTION 11-8

DECALS



TABLE OF CONTENTS

FIGURE NO.	TITLE	PAGE NO.
11-8-1	Decal Installation - Domestic	11-8-2
11-8-2	Decal Installation - Latin American	11-8-6

**S
E
C
T
I
O
N

1
1
-
8

D
E
C
A
L
S**

SECTION 11-8 DECALS



FIGURE 11-8-1. DECALS INSTALLATION -DOMESTIC.

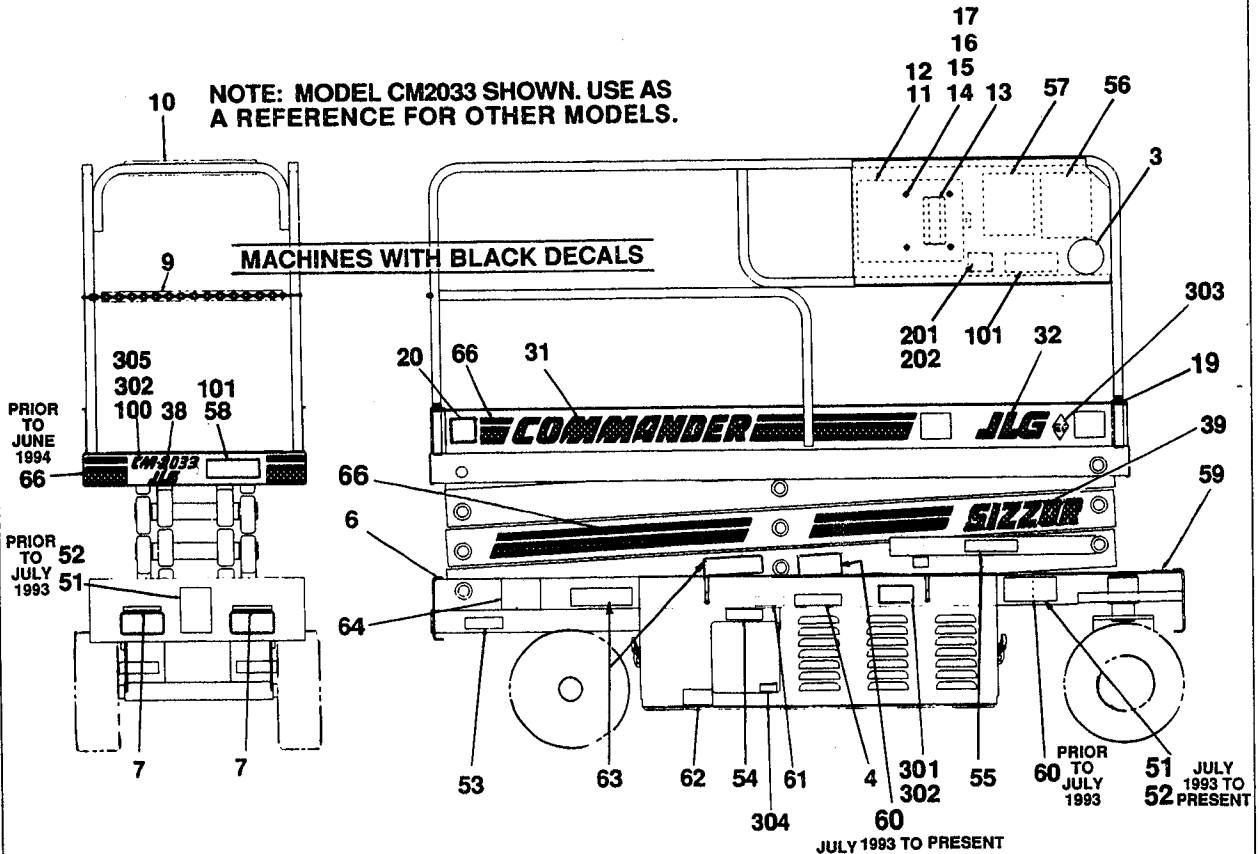
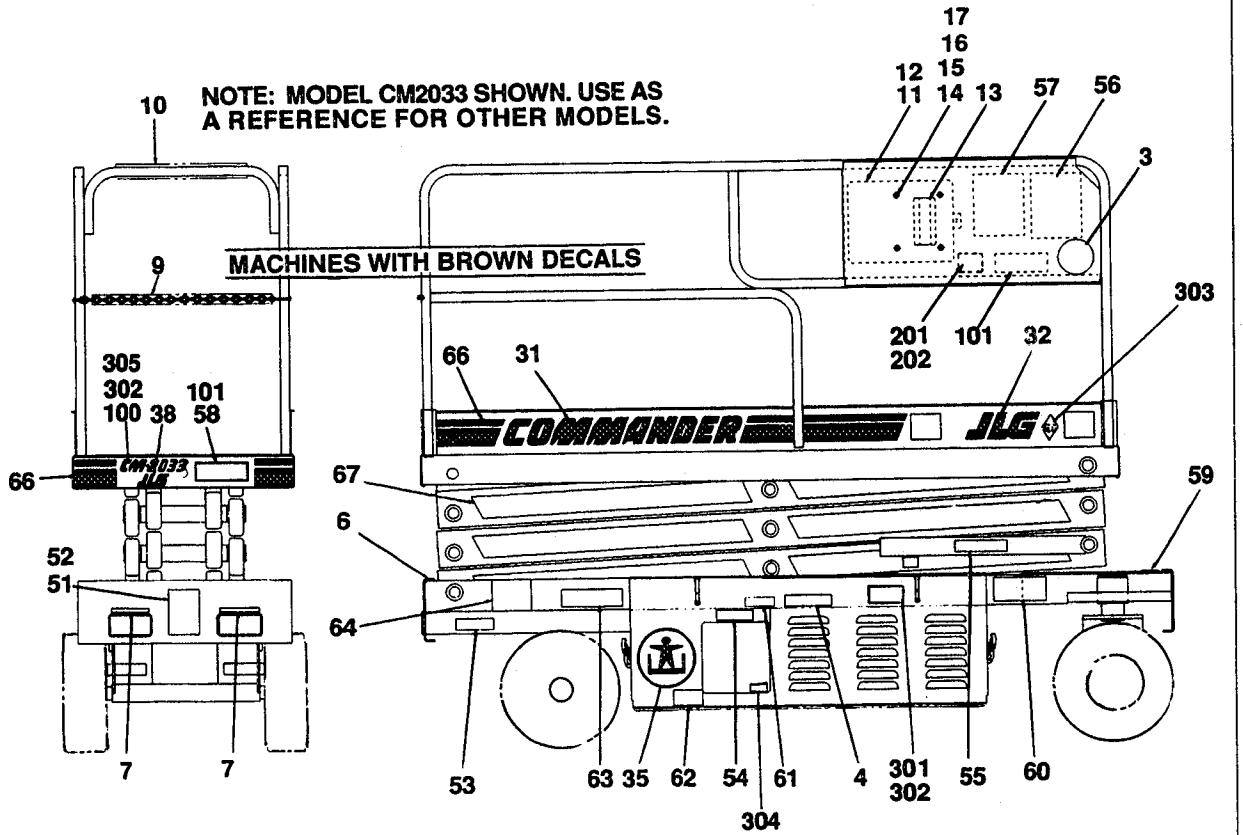

SECTION 11-8 DECALS

SECTION 11-8 DECALS



FIGURE & ITEM NO	PART NUMBER	DESCRIPTION	QTY.	REV.
11-8-1		DECALS INSTALLATION - DOMESTIC	Ref.	
	1281456	DECALS INSTALLATION - (PRIOR TO AUGUST 1991) (COMMON PARTS - STANDARD)	Ref.	D
	1281604	DECALS INSTALLATION - (AUGUST 1991 TO PRESENT) (COMMON PARTS - STANDARD)	Ref.	N
-1	Not Used			
-2	Not Used			
-3	3251813**	Decal - USA	1	
-4	1700195	Decal - Hydraulic Fluid (Prior to August 1991)	1	
	1701504**	Decal - Hydraulic Fluid (August 1991 to Present)	1	
-5	Not Used			
-6	4420039	Tape, Safety Tread	2 ft./61m	
-7	1701404	Decal - Fork Lift Area (Prior to August 1991)	2	
	1701508**	Decal - Fork Lift Area (August 1991 to Present)	2	
-8	Not Used			
-9	2820024	Tubing, Vinyl	2 ft./61m	
-10	3340612	Pad, Bumper	2 ft./61m	
-11	0860520	Box, Manual Storage	1	
-12	1060279	Cable, Lanyard	1	
-13	1700157	Decal - Manual (Prior to August 1991)	1	
	1701509**	Decal - Manual (August 1991 to Present)	1	
-14	0641405	Bolt 1/4"-20NC x 5/8"	4	
-15	4751400	Flatwasher 1/4"	4	
-16	4761400	Lockwasher 1/4"	4	
-17	3311401	Nut 1/4"-20NC	4	
-18	Not Used			
-19	0840035	Boot, Handrail (March 1994 to Present Only)	4	
-20	1702631	Decal - Bar Code (August 1995 to Present)	1	
	1281456	DECALS INSTALLATION - BROWN (PRIOR TO AUGUST 1991) (COMMON PARTS - VARIABLE)	Ref.	D
	1281604	DECALS INSTALLATION - BROWN (AUGUST 1991 TO PRESENT) (COMMON PARTS - VARIABLE)	Ref.	N
-31	1701069*	Decal - Commander (Brown)	2	
-32	1701110*	Decal - JLG (Brown)	3	
-33	Not Used			
-34	Not Used			
-35	1701408*	Decal - Logo (Brown)	2	
-36	Not Used			
-37	Not Used			
-38	1701409*	Decal - JLG (Brown)	1	
-39	Not Required			
	2900809	----- Decal Kit - Brown (Includes Items With *)	1	
	1281604	DECALS INSTALLATION - BLACK (COMMON PARTS - VARIABLE)	Ref.	N
-31	1702011+	Decal - Commander (Black) (April 1993 to Present)	2	
	1701613	Decal - Commander (Black) (Prior to April 1993)	2	

SECTION 11-8 DECALS

SECTION 11-8 DECALS



FIGURE & ITEM NO	PART NUMBER	DESCRIPTION	QTY.	REV.
11-8-1		DECALS INSTALLATION - DOMESTIC (CONTINUED)	Ref.	
-32	1702009 ⁺	Decal - JLG (Black) (April 1993 to Present)	3	
	1701435	Decal - JLG (Black) (Prior to April 1993)	3	
-33	Not Used			
-34	Not Used			
-35	Not Required			
-36	Not Used			
-37	Not Used			
-38	1702010 ⁺	Decal - JLG (Black) (April 1993 to Present)	1	
	1701612	Decal - JLG (Black) (Prior to April 1993)	1	
-39	1702029 ⁺	Decal - Sizzor (Black) (April 1993 to Present Only)	2	
	2900810	----- Decal Kit - Black (Includes Items With +)	1	
	1281604	DECALS INSTALLATION (STANDARD PARTS)	Ref.	N
-51	Consult Factory	Nameplate, Serial Number	1	
-52	3820014	Rivet 1/8" x 5/16"	4	
-53	1701071	Decal - Brake Release	1	
-54	1701122	Decal - Ground Control	1	
-55	1700713	Decal - Safety Prop	1	
-56	3252061	Decal - Caution	1	
-57	3251308	Nameplate	1	
-58	3820011	Rivet 1/8" x 1/8"	4	
-59	1701437	Decal - Manual Lowering	1	
-60	1701250	Decal - Danger (Crushing Hazard)	2	
-61	1700719	Decal - Danger (Battery Compartment)	2	
-62	1701411	Decal - Warning (Battery Charger)	1	
-63	3250873	Nameplate - Danger (Electrocution)	2	
-64	1700593	Decal - Inspection	1	
-65	Not Used			
-66	1700431	Decal - Brown/Orange Stripe (Machines With Brown Decals)	A/R	
	1701334	Decal - Black Stripe (Machines With Black Decals Built Prior to April 1993)	A/R	
	1702015	Decals - Black Stripe (Machines with Black Decals Built April 1993 to Present)	A/R	
-67	1701310	Decal - Orange Stripe (Machines With Brown Decal Only)	A/R	
		DECALS INSTALLATION - CM2033	Ref.	
-100	1701403	Decal - CM2033 (Brown)	2	
	1701607	Decal - CM2033 (Black) (Prior to April 1993)	2	
	1702018	Decal - CM2033 (Black) (April 1993 to Present)	2	
-101	3252045	Decal - Work Load (Standard)	2	
	3252127	Decal - Work Load (Ford Spec)	2	
	3252433	Decal - Work Load (Hydraulic Extended Platform)	2	

SECTION 11-8 DECALS

SECTION 11-8 DECALS



FIGURE & ITEM NO	PART NUMBER	DESCRIPTION	QTY.	REV.
11-8-1		DECALS INSTALLATION - DOMESTIC (CONTINUED)	Ref.	
		DECALS INSTALLATION - CM2046	Ref.	
-100	1701405	Decal - CM2046 (Brown)	2	
	1701608	Decal - CM2046 (Black) (Prior to April 1993)	2	
	1702019	Decal - CM2046 (Black) (April 1993 to Present)	2	
-101	3252059	Decal - Work Load (Standard)	2	
	3252045	Decal - Work Load (4Ft Hydraulically Extended Platform)	2	
	3252466	Decal - Work Load (6Ft Hydraulically Extended Platform)	2	
		DECALS INSTALLATION - CM2546	Ref.	
-100	1701406	Decal - CM2546 (Brown)	2	
	1701609	Decal - CM2546 (Black) (Prior to April 1993)	2	
	1702020	Decal - CM2546 (Black) (April 1993 to Present)	2	
-101	3252045	Decal - Work Load (Standard)	2	
	3252433	Decal - Work Load (Hydraulically Extended Platform)	2	
		DECAL INSTALLATION - CM2558	Ref.	
-100	1701407	Decal - CM2558 (Brown)	2	
	1701610	Decal - CM2558 (Black) (Prior to April 1993)	2	
	1702021	Decal - CM2558 (Black) (April 1993 to Present)	2	
-101	3252059	Decal - Work Load (Standard)	2	
	3252433	Decal - Work Load (Hydraulically Extended Platform)	2	
	0252972	CSA NAMEPLATE INSTALLATION	Ref.	—
-201	3252191	Nameplate - CSA	1	
-202	3820011	Rivet	4	
	0253760	U/L NAMEPLATE INSTALLATION	Ref.	A
-301	3251503	Nameplate - Battery Info	2	
-302	3820014	Rivet	12	
-303	3251899	Nameplate - EE	2	
-304	3251960	Nameplate - Fuse	1	
-305	3251921	Nameplate - U/L (Prior to July 1995)	1	
	3252474	Nameplate - U/L (July 1995 to Present)	1	

SECTION 11-8 DECALS

SECTION 11-8 DECALS



FIGURE 11-8-2. DECALS INSTALLATION -LATIN AMERICAN.

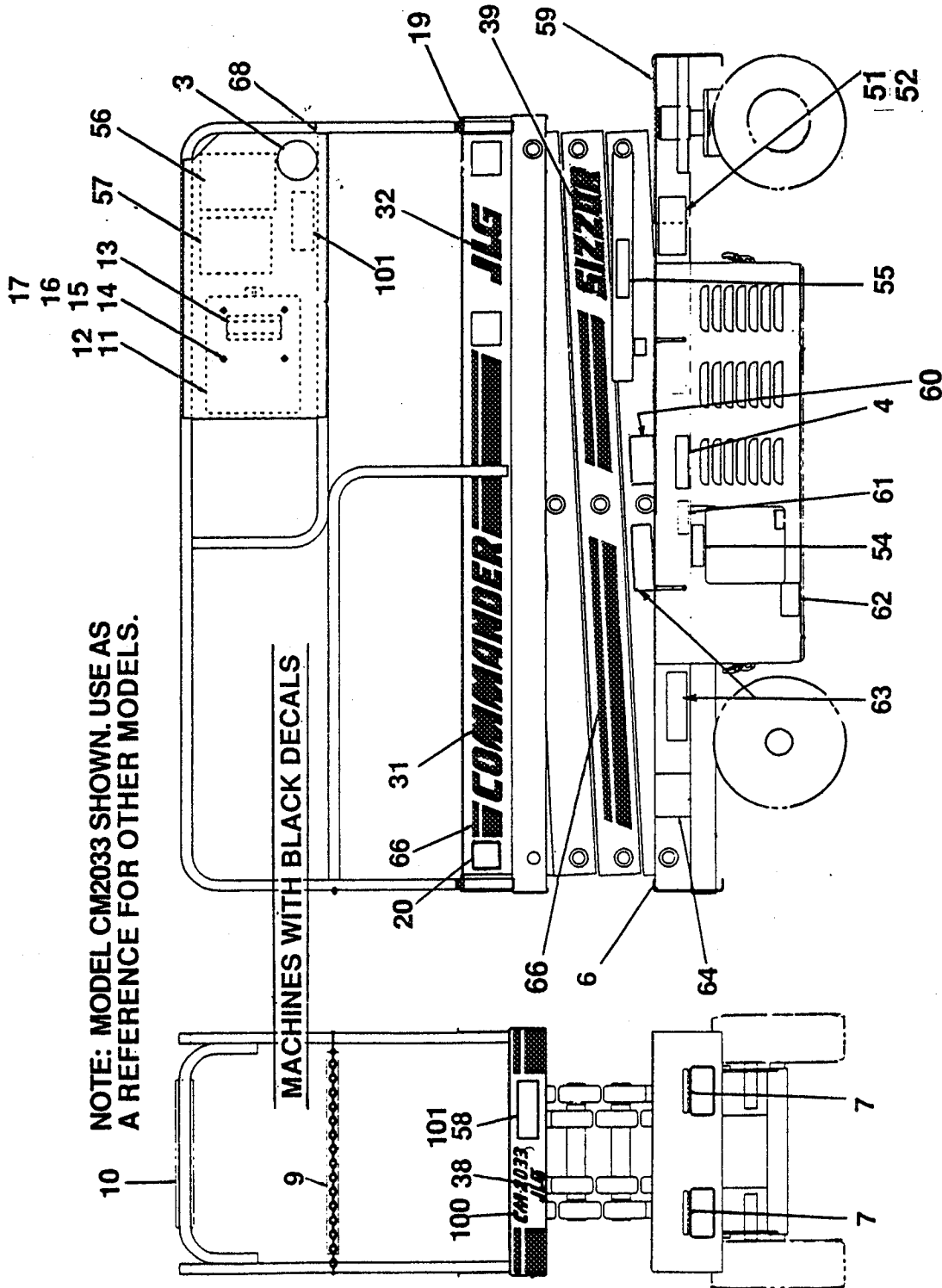

07ACMU 001 ZOHOMO

SECTION 11-8 DECALS



FIGURE & ITEM NO	PART NUMBER	DESCRIPTION	QTY.	REV.
11-8-2		DECALS INSTALLATION - LATIN AMERICAN	Ref.	
	1281604	DECALS INSTALLATION - (AUGUST 1991 TO PRESENT) (COMMON PARTS - STANDARD)	Ref.	N
-1	Not Used			
-2	Not Used			
-3	3251813 ⁺	Decal - USA	1	
-4	1701504 ⁺	Decal - Hydraulic Fluid	1	
-5	Not Used			
-6	4420039	Tape, Safety Tread	2 ft./61m	
-7	1701508 ⁺	Decal - Fork Lift Area	2	
-8	Not Used			
-9	2820024	Tubing, Vinyl	2 ft./61m	
-10	3340612	Pad, Bumper	2 ft./61m	
-11	0860520	Box, Manual Storage	1	
-12	1060279	Cable, Lanyard	1	
-13	1701509 ⁺⁺	Decal - Manual	1	
-14	0641405	Bolt 1/4"-20NC x 5/8"	4	
-15	4751400	Flatwasher 1/4"	4	
-16	4761400	Lockwasher 1/4"	4	
-17	3311401	Nut 1/4"-20NC	4	
-18	Not Used			
-19	0840035	Boot, Handrail (March 1994 to Present Only)	4	
-20	1702631	Decal - Bar Code (August 1995 to Present)	1	
	1281604	DECALS INSTALLATION - BLACK (COMMON PARTS - VARIABLE)	Ref.	N
-31	1702011 ⁺	Decal - Commander (Black) (April 1993 to Present)	2	
	1701613	Decal - Commander (Black) (Prior to April 1993)	2	
-32	1701435	Decal - JLG (Black)	3	
-33	Not Used			
-34	Not Used			
-35	Not Required			
-36	Not Used			
-37	Not Used			
-38	1702010 ⁺	Decal - JLG (Black)	1	
-39	1702029 ⁺	Decal - Sizzor (Black)	2	
	2900810	----- Decal Kit - Black (Includes Items With ⁺)	1	
	1281604	DECALS INSTALLATION (STANDARD PARTS)	Ref.	N
-51	Consult Factory	Nameplate, Serial Number	1	
-52	3820014	Rivet 1/8" x 5/16"	4	
-53	Not Used			
-54	1701858	Decal - Ground Control	1	
-55	1701856	Decal - Safety Prop	1	
-56	3252555	Decal - Caution	1	
-57	3252556	Nameplate	1	

SECTION 11-8 DECALS

SECTION 11-8 DECALS



FIGURE & ITEM NO	PART NUMBER	DESCRIPTION	QTY.	REV.
11-8-2		DECALS INSTALLATION - LATIN AMERICAN (CONTINUED)	Ref.	
-58	3820011	Rivet 1/8" x 1/8"	16	
-59	1701510	Decal - Manual Lowering	1	
-60	1702559	Decal - Danger (Crushing Hazard)	2	
-61	1702560	Decal - Danger (Battery Compartment)	2	
-62	1702553	Decal - Warning (Battery Charger)	1	
-63	1702554	Nameplate - Danger (Electrocution)	2	
-64	1702552	Decal - Inspection	1	
-65	Not Used			
-66	1702015	Decal - Stripe	A/R	
-67	Not Used			
-68	3252454	Nameplate - Platform Extension Capacity	1	
	0255599	DECALS INSTALLATION - CM2033	Ref.	—
-100	1702018	Decal - CM2033	2	
-101	3252450	Decal - Work Load	2	
	0255600	DECALS INSTALLATION - CM2046	Ref.	A
-100	1702019	Decal - CM2046	2	
-101	3252451	Decal - Work Load	2	
	0255601	DECALS INSTALLATION - CM2546	Ref.	—
-100	1702020	Decal - CM2546	2	
-101	3252450	Decal - Work Load	2	
	0255602	DECALS INSTALLATION - CM2558	Ref.	—
-100	1702021	Decal - CM2558	2	
-101	3252451	Decal - Work Load	2	



TRANSFER OF OWNERSHIP

To: JLG, Gradall, Lull and Sky Trak product owner:

If you now own, but ARE NOT the original purchaser of the product covered by this manual, we would like to know who you are. For the purpose of receiving safety-related bulletins, it is very important to keep JLG Industries, Inc. updated with the current ownership of all JLG products. JLG maintains owner information for each JLG product and uses this information in cases where owner notification is necessary.

Please use this form to provide JLG with updated information with regard to the current ownership of JLG Products. Please return completed form to the JLG Product Safety & Reliability Department via facsimile (717) 485-6573 or mail to address as specified on the back of this form.

Thank you,
Product Safety & Reliability Department
JLG Industries, Inc.
1 JLG Drive
McConnellsburg, PA 17233-9533
Telephone: (717) 485-5161
Fax: (717) 485-6573

NOTE: Leased or rented units should not be included on this form.

Mfg. Model: _____

Serial Number: _____

Previous Owner: _____

Address: _____

City: _____ State: _____

Zip: _____ Telephone: (_____) _____

Date Of Transfer: _____

Current Owner: _____

Address: _____

City: _____ State: _____

Zip: _____ Telephone: (_____) _____

Who in your organization should we notify?

Name: _____

Title: _____

Please cut on the dotted line and fax to 717-485-6573





Corporate Office
JLG Industries, Inc.
1 JLG Drive
McConnellsburg PA. 17233-9533
USA
Phone: (717) 485-5161
Fax: (717) 485-6417

JLG Worldwide Locations

JLG Industries (Australia)
P.O. Box 5119
11 Bolwarra Road
Port Macquarie
N.S.W. 2444
Australia
Phone: (61) 2 65 811111
Fax: (61) 2 65 810122

JLG Industries (UK)
Unit 12, Southside
Bredbury Park Industrial Estate
Bredbury
Stockport
SK6 2sP
England
Phone: (44) 870 200 7700
Fax: (44) 870 200 7711

JLG Deutschland GmbH
Max Planck Strasse 21
D-27721 Ritterhude/Idpohl
Bei Bremen
Germany
Phone: (49) 421 693 500
Fax: (49) 421 693 5035

JLG Industries (Italia)
Via Po. 22
20010 Pregnana Milanese - MI
Italy
Phone: (39) 02 9359 5210
Fax: (39) 02 9359 5845

JLG Latino Americana Ltda.
Rua Eng. Carlos Stevenson,
80-Suite 71
13092-310 Campinas-SP
Brazil
Phone: (55) 19 3295 0407
Fax: (55) 19 3295 1025

JLG Europe B.V.
Jupiterstraat 234
2132 HJ Foofddorp
The Netherlands
Phone: (31) 23 565 5665
Fax: (31) 23 557 2493

JLG Industries (Norge AS)
Sofeimyrveien 12
N-1412 Sofienyr
Norway
Phone: (47) 6682 2000
Fax: (47) 6682 2001

JLG Polska
Ul. Krolewska
00-060 Warszawa
Poland
Phone: (48) 91 4320 245
Fax: (48) 91 4358 200

JLG Industries (Europe)
Kilmartin Place,
Tannochside Park
Uddingston G71 5PH
Scotland
Phone: (44) 1 698 811005
Fax: (44) 1 698 811055

JLG Industries (Pty) Ltd.
Unit 1, 24 Industrial Complex
Herman Street
Meadowdale
Germiston
South Africa
Phone: (27) 11 453 1334
Fax: (27) 11 453 1342

Plataformas Elevadoras
JLG Iberica, S.L.
Trapadella, 2
P.I. Castellbisbal Sur
08755Castellbisbal
Spain
Phone: (34) 93 77 24700
Fax: (34) 93 77 11762

JLG Industries (Sweden)
Enkopingsvagen 150
Box 704
SE - 175 27 Jarfalla
Sweden
Phone: (46) 8 506 59500
Fax: (46) 8 506 59534
